

### FEATURES

- Low cost integrated monolithic GaAs amplifier with step attenuator.
- Attenuation Range: 0 – 58 dB, variable in 1 dB steps via 8 bit serial input.
- Meets DOCSIS distortion requirements at +60 dBmV
- Low distortion & Low noise figure
- Frequency range: 5 – 100 MHz
- 5 Volt operation

### APPLICATIONS

- MCNS/DOCSIS Compliant Cable Modems
- CATV Interactive Set-Top Box
- Telephony over Cable Systems
- Open Cable Set-Top Box



### Description

The ARA2001S23 is a GaAs IC designed to provide the reverse path amplification and output level control functions in a CATV Set-Top Box or Cable Modem. It incorporates a digitally controlled precision step attenuator that is preceded by an ultra low noise amplifier stage, and followed by an ultra-linear output driver amplifier. This part is a balanced design that meets or exceeds the MCNS/DOCSIS requirement for harmonic performance @ +60dBmV output levels while only requiring a single polarity +5V supply. Both the input and output are matched to 75 ohms. The precision attenuator provides up to 58 dB of attenuation in 1 dB increments. The ARA2001S23 is supplied in a 28-pin SSOP package featuring a thermal heat slug on the bottom of the package. Soldering this heat slug to the ground plane of the PC board ensures the lowest possible thermal resistance for the device resulting in a long MTF.

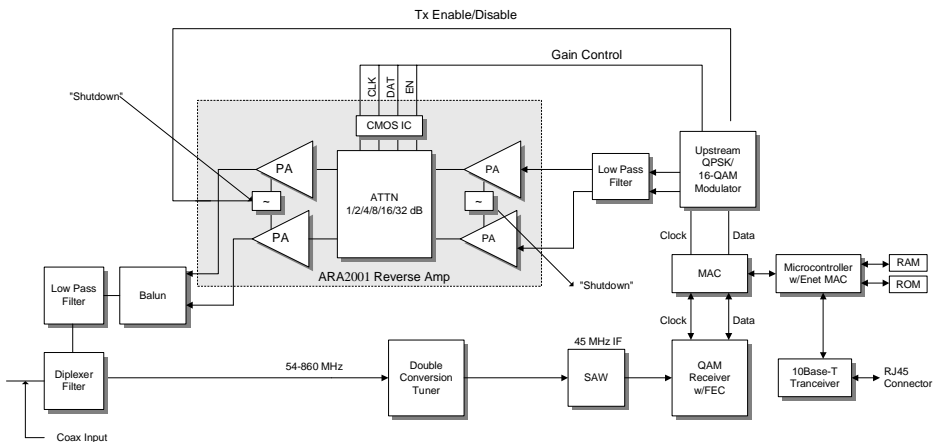

**Figure 1: Cable Modem or Interactive Set-Top Box Block Diagram**

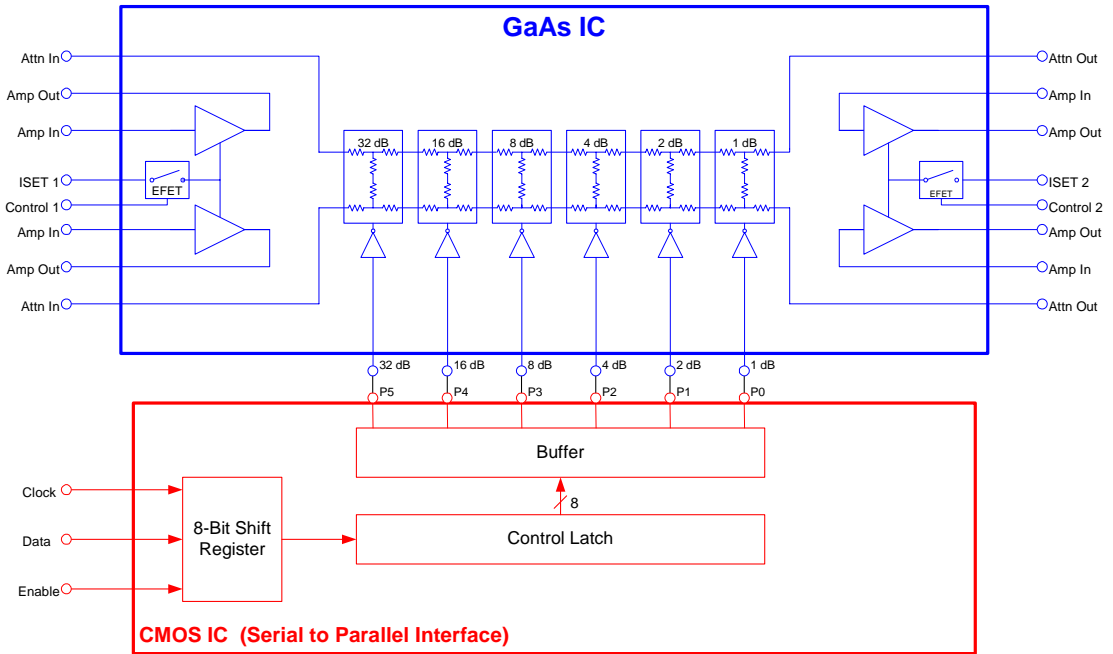

Figure 2: ARA 2001 Block Diagram

ABSOLUTE MAXIMUM RATINGS		
PARAMETER	PARAMETER	
V <sub>DD</sub> (PINS 2,4,9,21,24)	9	VDC
V <sub>RFIN</sub> (PINS 5,8)	0 to -3	VDC
ATT <sub>IN</sub> (3,10) ATT <sub>OUT</sub> (19,26)V	5	VDC
I <sub>SET</sub> (PINS 7, 22)	2	VDC
RF Input Voltage (PINS 5,8)*	+ 60	dBmV
Storage Temperature	- 55 to +200	°C
Soldering Temperature	260	°C
Soldering Time	5	Sec
Operating Case Temperature	0 to + 85	°C

ELECTRICAL CHARACTERISTICS (TYPICAL) ( $V_{DD} = 5 V_{DC}$ ,  $T_C = 25^\circ C$ )

PARAMETER	MIN	TYP	MAX	UNIT	COMMENTS	
Gain <sup>1</sup> @ 10 MHz	27.5	29.3	30.5	dB	At 0dB attenuation setting	
Gain Flatness <sup>1</sup>	-	0.75	-	dB	5 to 42 MHz	
Gain Variation Over Temp	-	-0.006	-	dB/°c		
Attenuation Steps <sup>1</sup>						
1 dB	0.65	0.83	1.00	dB		
2 dB	1.6	1.70	2.05			
4 dB	3.6	3.75	4.0			
8 dB	7.5	7.75	8.0			
16 dB	15.0	15.40	15.8			
32 dB	30.2	30.75	31.3			
2 <sup>nd</sup> Harmonic Distortion Level <sup>2</sup>	10 MHz	-	-75	-53	dBc	at +60 dBmV
3 <sup>rd</sup> Harmonic Distortion Level <sup>2</sup>	10 MHz	-	-60	-53	dBc	at +60 dBmV
3 <sup>rd</sup> Order Output Intercept Point		78	-	-	dBmV	
1 dB Gain Compression Point		-	68.5	-	dBmV	
Noise Figure <sup>1</sup>		-	3.0	4.0	dB	Includes input balun loss
Output Noise Power						
Active/No Signal/Min Attn. Setting		-	-	-25.5	dBmV	Any 3200 KHz bandwidth from 5-42 MHz
Active/No Signal/Max Attn. Setting		-	-	-40.8		
Isolation in Tx disable mode @ 45 MHz		-	65	-	dB	Difference in output signal level between Tx enable / disable
Input Impedance <sup>1</sup>		-	75	-	ohm	
Input Return Loss <sup>1</sup>		-	-20	-12	dB	Tx enabled
Input Return Loss <sup>1</sup>		-	-5	-	dB	Tx disabled
Output Impedance <sup>1</sup>		-	75	-	ohm	
Output Return Loss <sup>1</sup>		-	-17	-12	dB	Tx enabled
Output Return Loss <sup>1</sup>		-	-15	-10	dB	Tx disabled
$V_{DD1}$ , $V_{DD2}$ (Pins 4, 9, 21, 24)		-	5	7	V	
$V_{DD}$ Digital (Pin 2)		-	5	-	V	
$V_{DD}$ CMOS (Pin 11)		3	-	5	V	
$I_{DD1}$ (Input Amp) (Pins 4 and 9)		-	48	80	mA	Tx enabled

**ELECTRICAL CHARACTERISTICS (TYPICAL) ( $V_{DD} = 5 V_{DC}$ ,  $T_c = 25^\circ C$ ) (Continued)**

PARAMETER	MIN	TYP	MAX	UNIT	COMMENTS
$I_{DD1}$	-	2.4	6	mA	Tx disabled
$I_{DD2}$ (Output Amp) (Pins 21 and 24)	-	77	120	mA	Tx enabled
$I_{DD2}$	-	3.7	9	mA	Tx disabled
$I_{DD}$ Digital (Attenuator) (Pin 2)	-	9	15	mA	
Power Consumption	-	0.67	1.08	W	Tx enabled
Power Consumption	-	75	150	mW	Tx disabled
Attenuator Step Size	0.6	-	1.4	dB	
Gain Flatness <sup>1</sup>	-	1.5	-	dB	5 - 65 MHz
Output Voltage Transient <sup>1</sup> Tx enable/disable	- -	- 4	100 7	mVp-p -	At 0 db Attenuator Setting At 24 db Attenuator Setting
Maximum Attenuation	58.6	60.3			

Notes:

1. As measured in ANADIGICS test fixture
2. At +60 dBmV output level into 75 ohm load

Attenuation Level vs Control Word

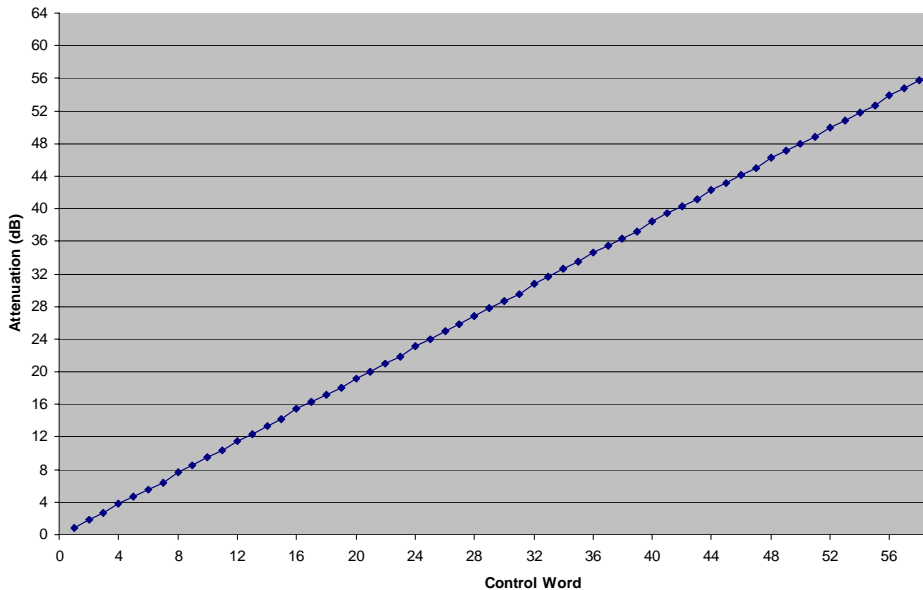

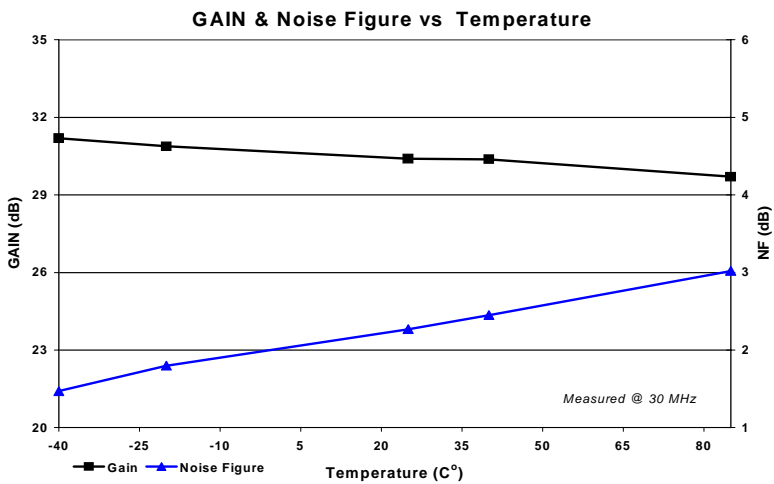
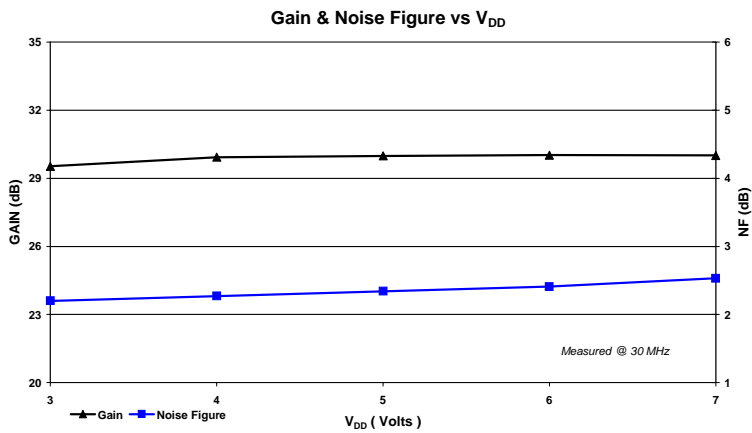
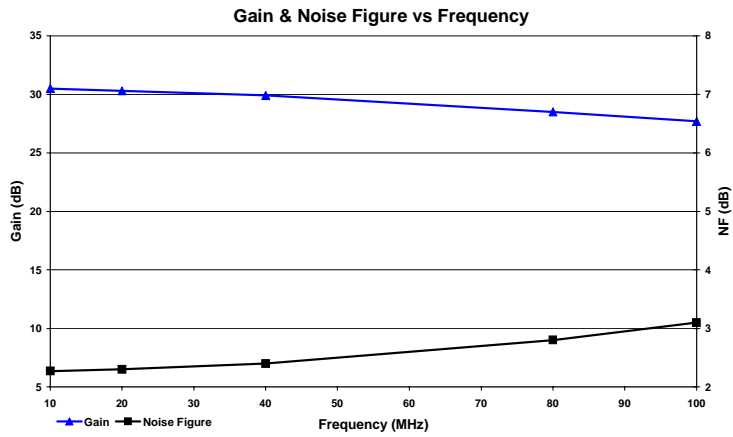

### Harmonic Distortion vs $V_{DD}$

$P_{out} = 58 \text{ dBmV}$

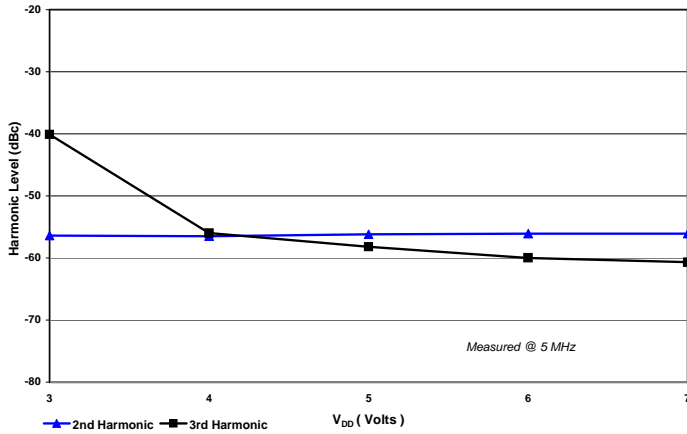

### Harmonic Distortion vs $V_{DD}$

$P_{out} = 58 \text{ dBmV}$

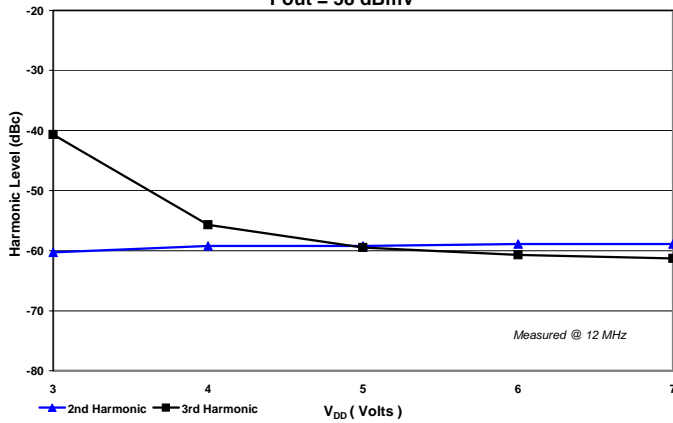

### Harmonic Distortion vs Temperature

$P_{out} = 58 \text{ dBmV}$

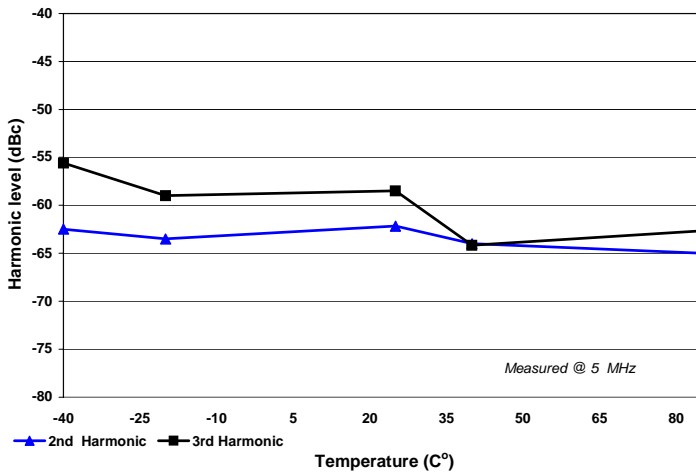

Harmonic Distortion vs Power Out

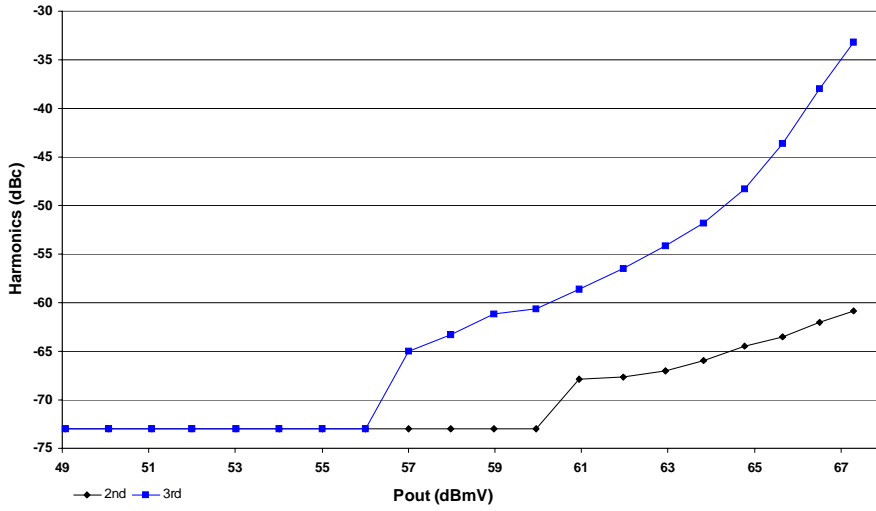

Measured @ 10 MHz

Transients vs Attenuation

P<sub>out</sub> = 55 dBmV at 0dB attenuation.

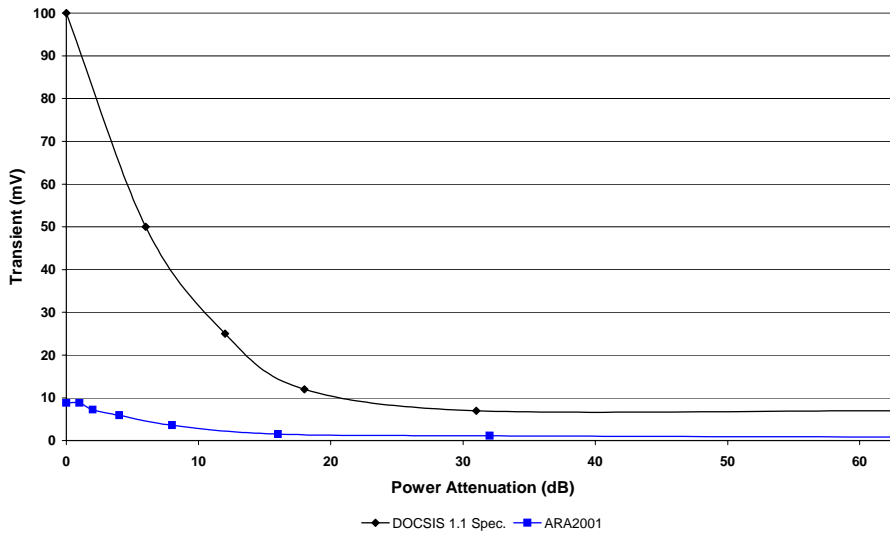

Harmonic Performance vs Frequency  
 Pout = +62 dBmV

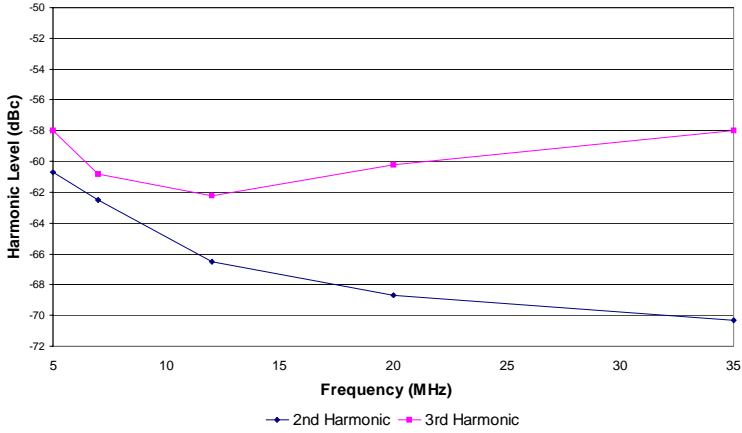

IIP<sub>2</sub> & IIP<sub>3</sub> vs Frequency

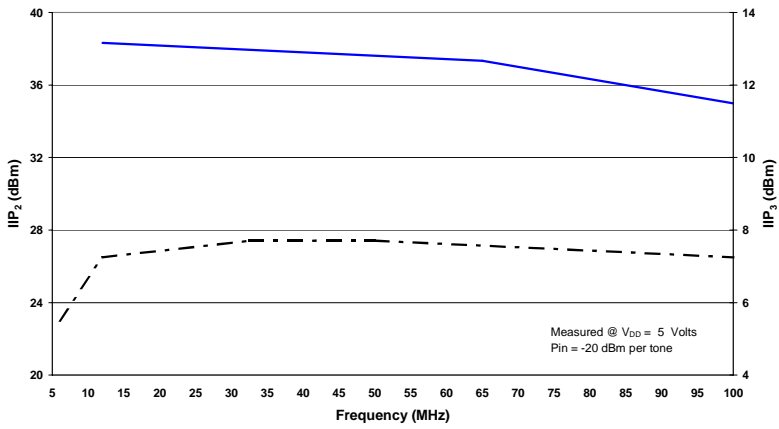

Measured @ V<sub>DD</sub> = 5 Volts  
 Pin = -20 dBm per tone

IIP<sub>2</sub> & IIP<sub>3</sub> vs V<sub>DD</sub>

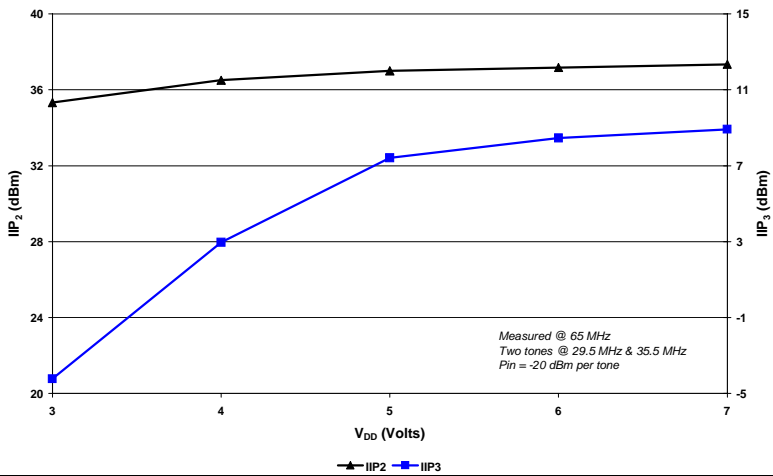

Measured @ 65 MHz  
 Two tones @ 29.5 MHz & 35.5 MHz  
 Pin = -20 dBm per tone



ARA2000 & 2001  
Balanced Reverse Amp Test Fixture with 3 Wire Interface

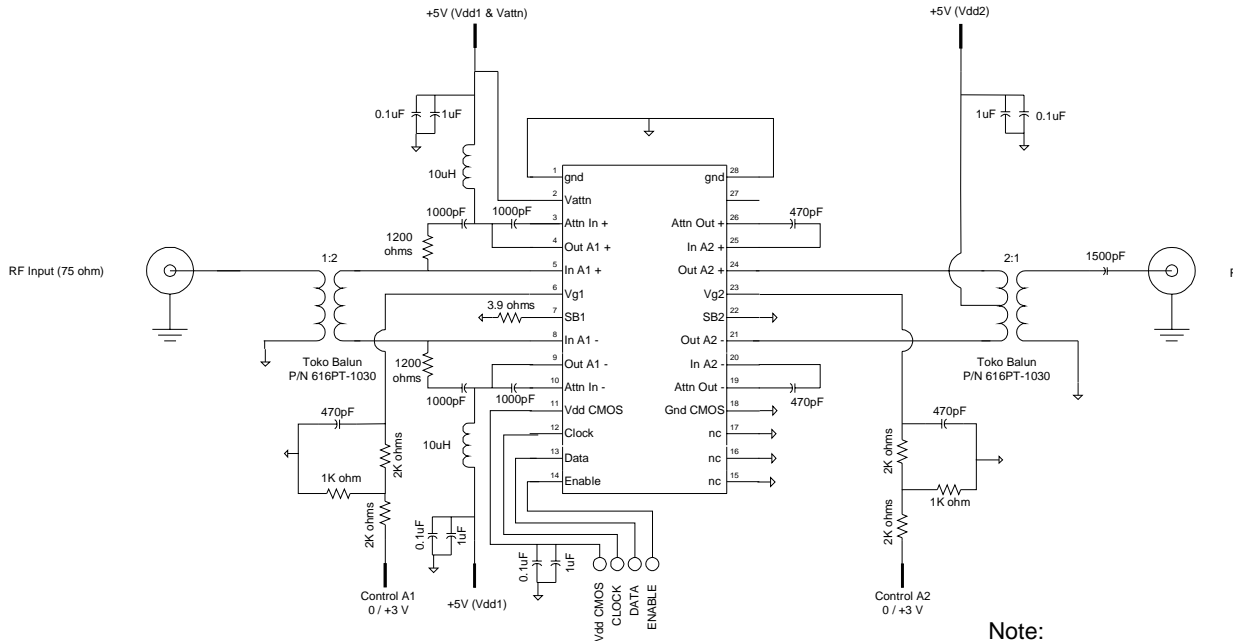

Note:

Tx Enable = Control  
Tx Disable = Control

TEST CIRCUIT

**Programming Word**

D <sub>0</sub>	D <sub>1</sub>	D <sub>2</sub>	D <sub>3</sub>	D <sub>4</sub>	D <sub>5</sub>	D <sub>6</sub>	D <sub>7</sub>
P0	P1	P2	P3	P4	P5	P6	P7

**Data Port Description**

SERIAL DATA	FUNCTION
P0	1 dB Attenuator Bit
P1	2 dB Attenuator Bit
P2	4 dB Attenuator Bit
P3	8 dB Attenuator Bit
P4	16 dB Attenuator Bit
P5	32 dB Attenuator Bit
P6	N/A
P7	N/A

**Figure 3**

**SERIAL DATA INPUT TIMING**

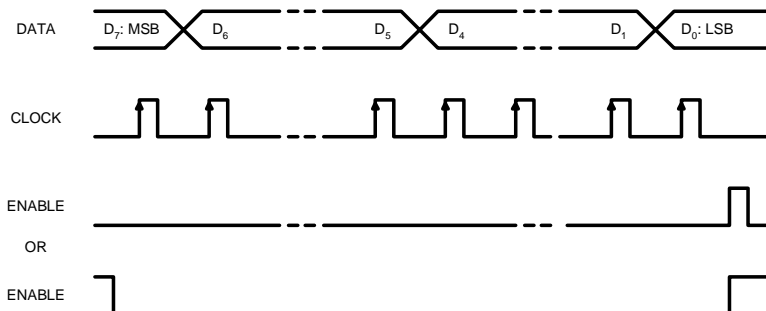
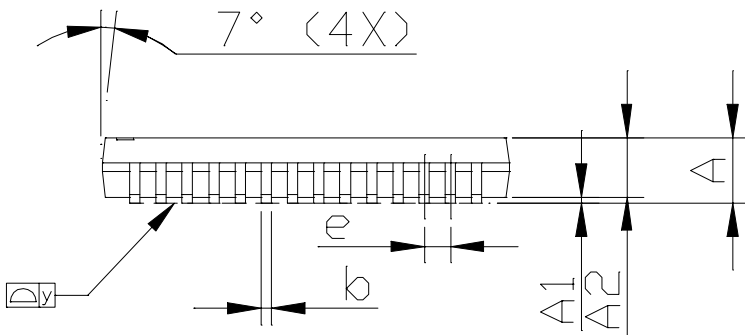
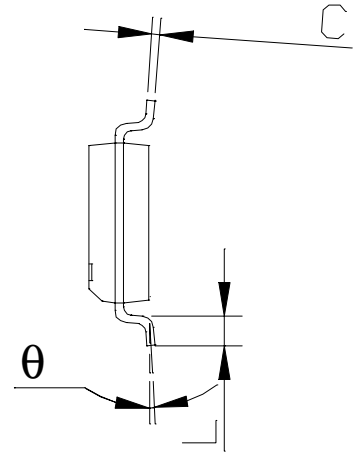
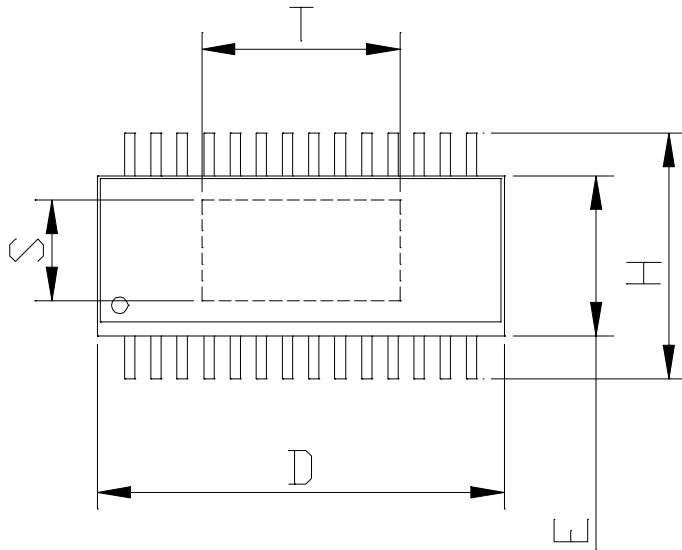

**Figure 4**

## PIN DESCRIPTION

Pin	Function	Description
1	Ground	
2	$V_{ATTN}$	Supply for Attenuator
3	$ATT_{IN} (+)$	Attenuator Input (+)
4	$A1_{OUT} (+)$	Amplifier 1 (+) Output
5	$A1_{IN} (+)$	Amplifier 1 (+) Input
6	$Vg1$	Amplifier A1 (+/-) Control
7	$I_{SET1}$	Amplifier A1 (+/-) Current Adjust
8	$A1_{IN} (-)$	Amplifier A1 (-) Input
9	$A1_{OUT} (-)$	Amplifier A1 (-) Output
10	$ATT_{IN} (-)$	Attenuator Input (-)
11	CMOS	Supply For Digital CMOS Circuit
12	CLK	Clock
13	DAT	Data
14	En	Enable
15	N/C	No Connection
16	N/C	No Connection
17	N/C	No connection
18	CMOS	Ground for Digital CMOS Circuit
19	$ATT_{OUT} (-)$	Attenuator Output (-)
20	$A2_{IN} (-)$	Amplifier A2 (-) Input
21	$A2_{OUT} (-)$	Amplifier A2 (-) Output
22	$I_{SET2}$	Amplifier A2 (+/-) Current Adjust
23	$Vg2$	Amplifier A2 (+/-) Control
24	$A2_{OUT} (+)$	Amplifier A2 (+) Output
25	$A2_{IN} (+)$	Amplifier A2 (+) Input
26	$ATT_{OUT} (+)$	Attenuator Output (+)
27	N/C	No Connection
28	GND	Ground

Package Outline



NOTE

1. PACKAGE BODY SIZES EXCLUDE MOLD FLASH AND GATE BURRS
2. TOLERANCE 0.004in.[0.10 mm] UNLESS OTHERWISE SPECIFIED
3. CONTROLLING DIMENSION ARE INCHES.
4. REF. - MO-137

SYMBOLS	DIMENSIONS IN INCHES		DIMENSIONS IN MILLIMETERS	
	MIN	MAX	MIN	MAX
A	0.057	0.061	1.45	1.55
A1	0.000	0.004	0.00	0.10
A2	0.057 (NOMINAL)		1.45 (NOMINAL)	
b	0.008	0.012	0.20	0.30
C	0.007	0.010	0.18	0.25
D	0.386	0.394	9.80	10.00
E	0.150	0.157	3.81	4.00
H	0.228	0.244	5.80	6.20
e	0.025 BSC		.64 BSC	
L	0.016	0.050	0.40	1.27
y	---	0.004	---	0.10
theta	0°	8°	0°	8°
T	---	0.190	---	4.82
S	---	0.096	---	2.43

98000-031

## NOTES

## NOTES

## NOTES



**ANADIGICS, Inc.**  
35 Technology Drive  
Warren, New Jersey 07059  
Tel: (908) 668-5000  
Fax: (908) 668-5132

<http://www.anadigics.com>  
[Mktg@anadigics.com](mailto:Mktg@anadigics.com)

**IMPORTANT NOTICE**

ANADIGICS, Inc. reserves the right to make changes to its products or discontinue any product at any time without notice. The Advanced Product data sheets and product specifications contained in this data sheet are subject to change prior to a products formal introduction. The information in this data sheet has been carefully checked and is assumed to be reliable. However, ANADIGICS assumes no responsibility for inaccuracies. ANADIGICS strongly urges customers to verify that the information they are using is current before placing orders.

**WARNING**

ANADIGICS products are not intended for use in life support appliances, devices, or systems. Use of an ANADIGICS product in any such application without written consent is prohibited.