

250mA CMOS Regulator

Monolithic IC MM312□□P

Outline

This is a 250mA output low saturation regulator IC that achieves low current consumption (1μA typ.). Output capacity is 0.1μF ESR-free, and the package is SOT89-3A, making it highly versatile for use in cordless telephones and portable devices. Output precision is ±2%.

Features

- | | |
|--|---|
| 1. Low current consumption | 1μA typ. (no load) |
| 2. Output voltage | 2.0~6.0V (0.1V step) |
| 3. Low input/output voltage difference | 180mV typ. (V _O =3.0V, I _{OUT} =80mA) |
| 4. Low output capacitor | 0.1μF |
| 5. Allowable loss | 500mW |

Package

SOT89-3A

Applications

1. Portable devices
2. AV equipment
3. PC peripherals with memory
4. Office equipment, etc.

Pin Assignment

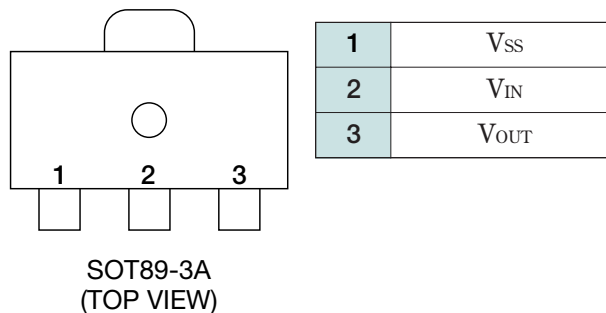

Block Diagram

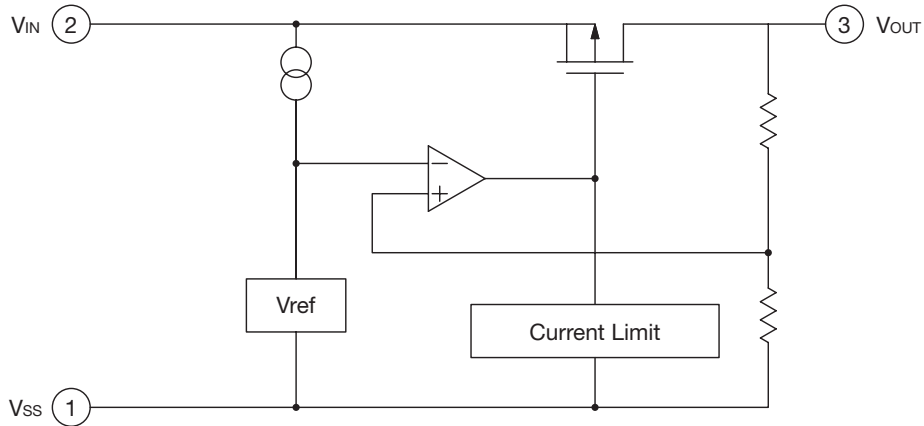

Pin Description

Pin no.	Pin name	Functions
1	V _{SS}	GND pin
2	V _{IN}	Voltage-supply pin
3	V _{OUT}	Output pin

Absolute Maximum Ratings (T_a=25°C)

Item	Symbol	Ratings	Units
Storage temperature	T _{STG}	-40~+125	°C
Supply voltage	V _{DD}	12	V
Output voltage	V _{OUT}	V _{SS} -0.3~V _{IN} +0.3	V
Output current	I _o max.	500	mA
Allowable loss	P _d	500	mW

Recommended Operating Conditions (T_a=25°C)

Item	Symbol	Ratings	Units
Operating ambient temperature	T _{JOP}	-40~+85	°C
Input voltage (max.)	V _{IN} max.	10	V

Electrical Characteristics 1 (Except where noted otherwise, Ta=25°C, VIN=VOUT (typ.) +1V, IOUT=40mA)

Item	Symbol	Measurement conditions	Min.	Typ.	Max.	Units
No-Load input current	I _{SS}	I _{OUT} =0mA		1	4.5	μA
Output voltage	V _{OUT}		×0.98		×1.02	V
Line Regulation	V _{LINE}	V _{IN} =V _O typ. +1~10V, I _{OUT} =40mA		0.2	0.3	%/V
Load Regulation	V _{LOAD}	Please refer to Electrical Characteristics 2				mV
Output current	I _{OUT}		250			mA
Dropout voltage 1	V _{IO1}	Please refer to Electrical Characteristics 2				V
Dropout voltage 2	V _{IO2}	Please refer to Electrical Characteristics 2				V
V _{OUT} temperature Coefficient *	ΔV _{OUT} /ΔT	I _{OUT} =40mA, -40 ≤ T _{OP} ≤ 85°C		±100		ppm/°C

* The parameter is guaranteed by design.

Electrical Characteristics 2 (Except where noted otherwise, Ta=25°C, VIN=VOUT (typ.) +1V, IOUT=40mA)

Model No.	Item												
	Output voltage			Dropout voltage 1			Dropout voltage 2			Load Regulation			
	VOUT (V)			VIO1 (mV)			VIO2 (mV)			VLOAD (mV)			
	Test conditions	Min.	Typ.	Max.	Test conditions	Typ.	Max.	Test conditions	Typ.	Max.	Test conditions	Typ.	Max.
MM3122A	IOUT=40mA	1.960	2.000	2.040	IOUT=60mA VIN=VO×0.98V	180	360	IOUT=120mA VIN=VO×0.98V	400	700	1mA ≤ IOUT ≤ 60mA VIN=VOUT+1V	10	90
MM3122B													
MM3122C													
MM3122D													
MM3122E													
MM3122F													
MM3122G													
MM3122H													
MM3122J													
MM3122K													
MM3123A													
MM3123B													
MM3123C	IOUT=40mA	3.136	3.200	3.264	IOUT=80mA VIN=VO×0.98V	180	360	IOUT=160mA VIN=VO×0.98V	400	700	1mA ≤ IOUT ≤ 80mA VIN=VOUT+1V	10	90
MM3123D													
MM3123E													
MM3123F													
MM3123G													
MM3123H													
MM3123J													
MM3123K													
MM3124A													
MM3124B													
MM3124C													
MM3124D		IOUT=40mA	4.214	4.300									
MM3124E													
MM3124F													
MM3124G													
MM3124H													
MM3124J													
MM3124K													
MM3125A													
MM3125B													
MM3125C													
MM3125D													
MM3125E	IOUT=40mA		5.292	5.400	5.508	IOUT=100mA VIN=VO×0.98V	120	300	IOUT=200mA VIN=VO×0.98V	380	600	1mA ≤ IOUT ≤ 100mA VIN=VOUT+1V	10
MM3125F													
MM3125G													
MM3125H													
MM3125J													
MM3125K													
MM3126A													

Measuring Circuit

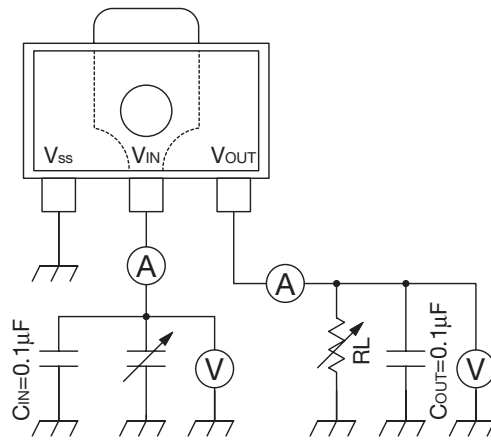

Application Circuit

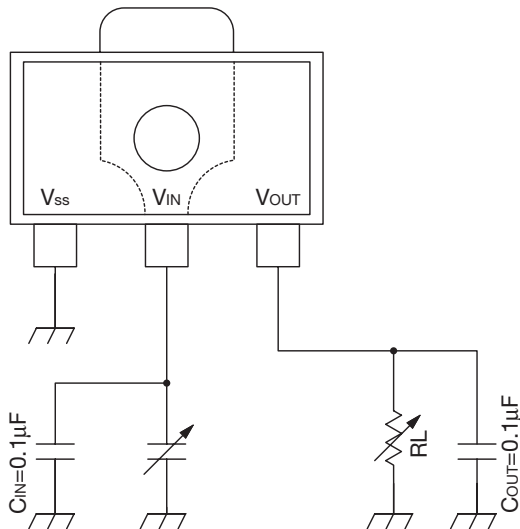

*Temperature Characteristics : B

Note: 1 The output capacitor is required between output and GND to prevent oscillation.

Note: 2 The ESR of capacitor must be defined in ESR stability area.

It is possible to use a ceramic capacitor without ESR resistance for output.

The ceramic capacitor must be used more than 0.1µF and B temperature characteristics.

Note: 3 The wire of Vin and Vss is required to print full ground plane for noise and stability.

Note: 4 The input capacitor must be connected a distance of less than 1cm from input pin.

Characteristics (Except where noted otherwise, $T_a=25^\circ\text{C}$, $V_{IN}=V_O+1\text{V}$, $C_{IN}=C_{OUT}=1.0\mu\text{F}$)

Output Voltage

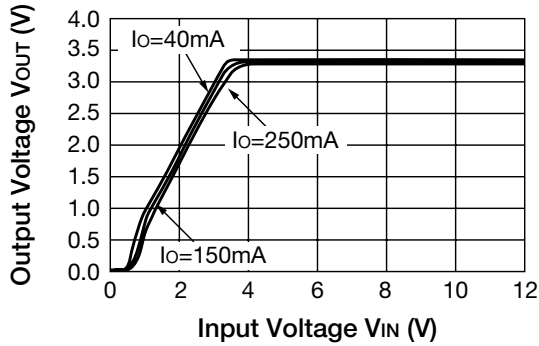

No-Load Input Current

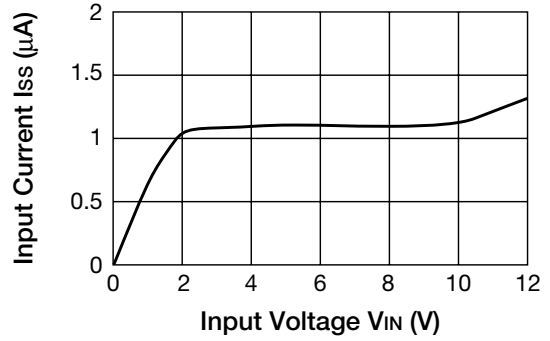

Line Regulation

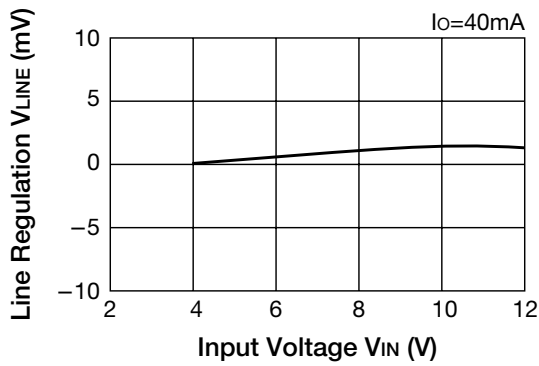

Load Regulation

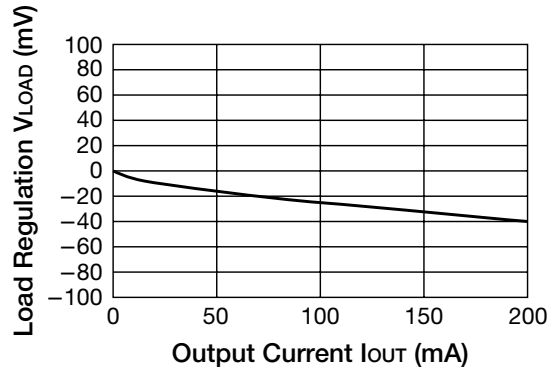

Dropout Voltage

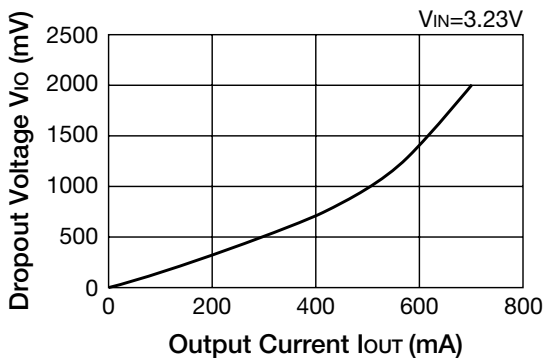

Current Limit

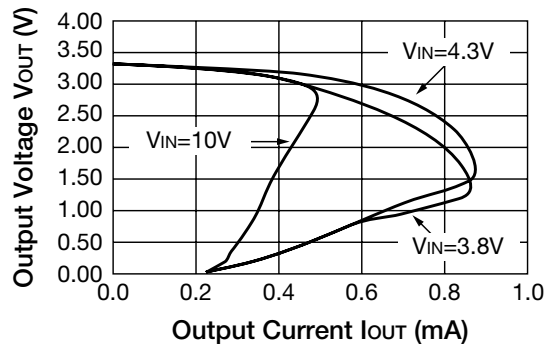

■ Load transient response (C_{OUT}=1μF)

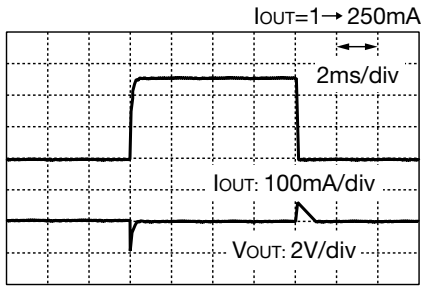

■ Load transient response (without C_{OUT})

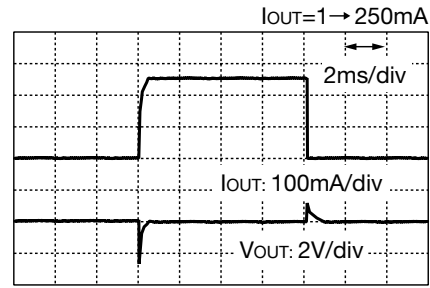

■ Input transient response (C_{OUT}=1μF)

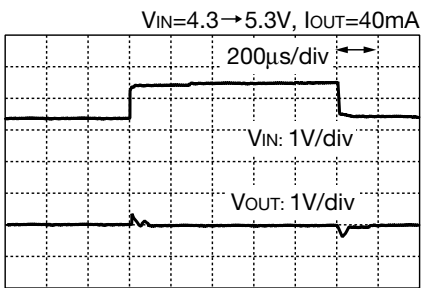

■ Input transient response (without C_{OUT})

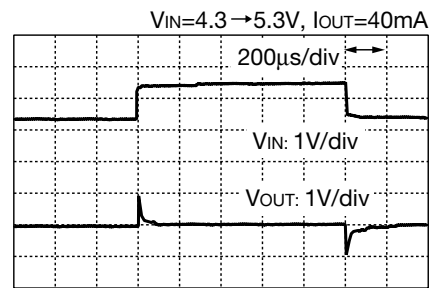

■ ESR

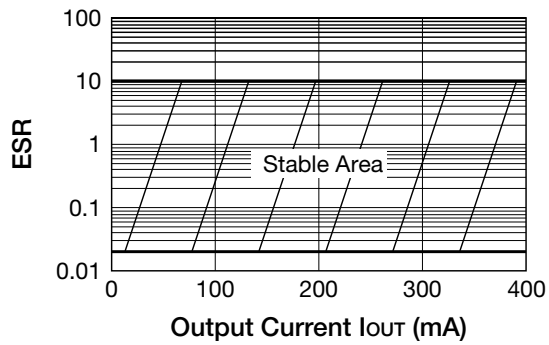

* ESR does not measure more than 10Ω.

■ Output Voltage

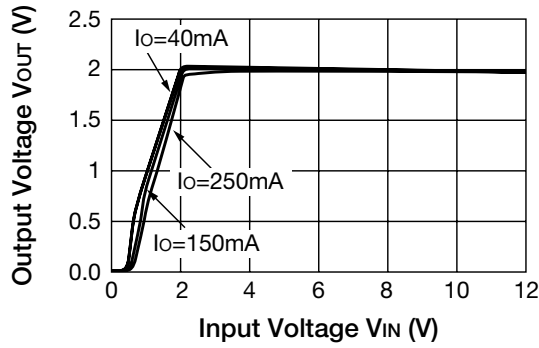

■ No-Load Input Current

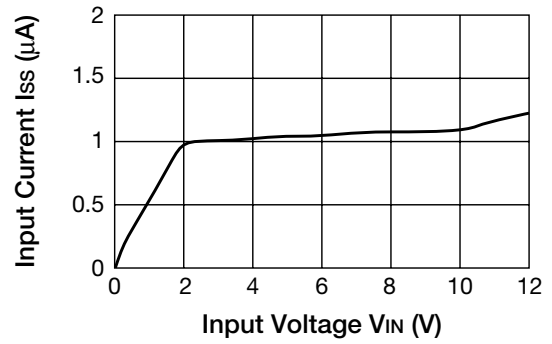

■ Line Regulation

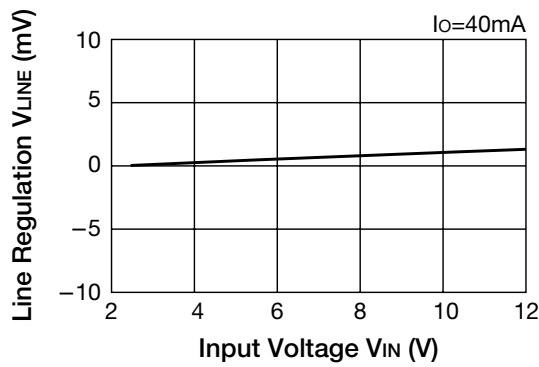

■ Load Regulation

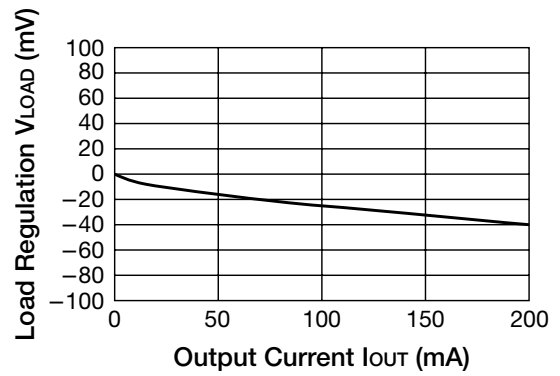

■ Dropout Voltage

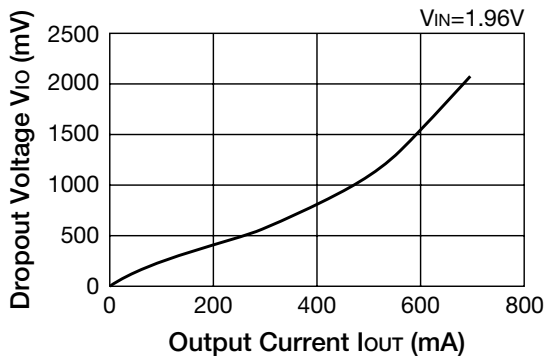

■ Output Voltage

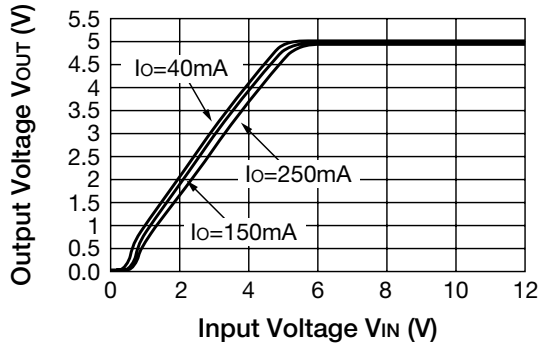

■ No-Load Input Current

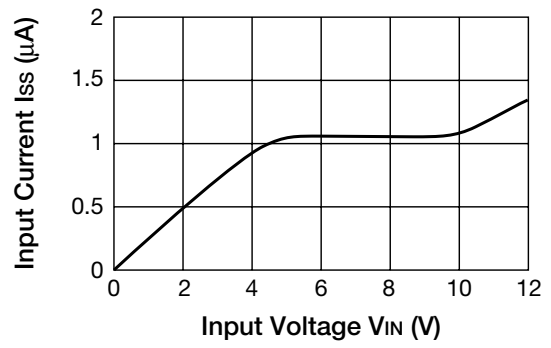

■ Line Regulation

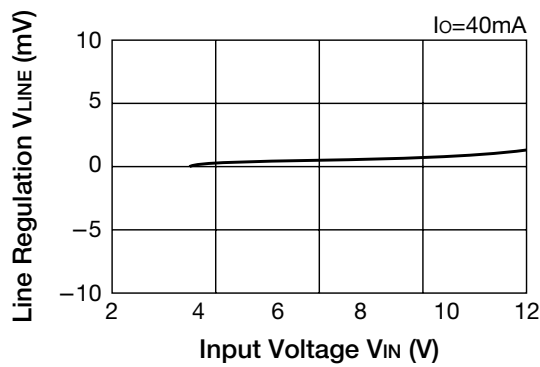

■ Load Regulation

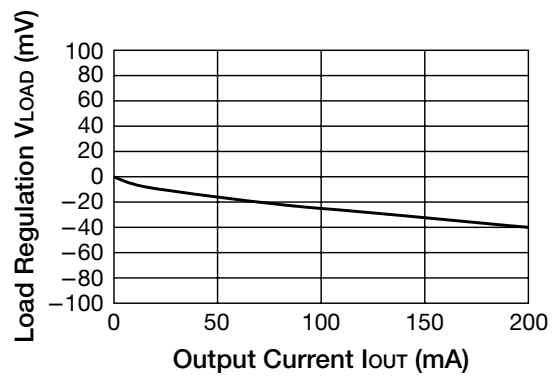

■ Dropout Voltage

