

Inductors

For High Frequency SMD

NLU Series NLU2012 Type

FEATURES

- Q has been increased by forming the special spiral-form conductor mainly composed of copper on the thin-film multilayer structure and reducing direct current resistance.
- Narrow inductance tolerance of $\pm 2\%$ or $\pm 0.2\text{nH}$ has been achieved by increasing the dimensional precision of the conductor and between them.
- Accurate dimensional precision has been achieved as well as excellent soldering heat resistance.
- Concurrent use with ultra-small chip components is possible due to the thickness of 0.6mm.
- Compatible with either reflow or flow soldering

APPLICATIONS

High-frequency circuits for portable telephones, pagers, or other mobile communication appliances.

SPECIFICATIONS

Operating temperature range	-40 to +100°C
Storage temperature range	-55 to +125°C [Unit of products]

RECOMMENDED REFLOW SOLDERING CONDITIONS

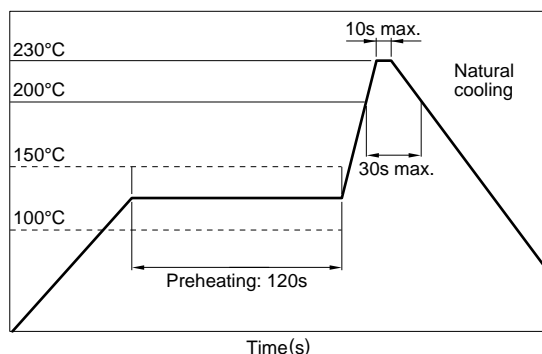

PRODUCT IDENTIFICATION

NLU	160805	T	-	2N2	C
(1)	(2)	(3)		(4)	(5)

(1) Series name

(2) Dimensions L×W×T

160805	1.6×0.8×0.58mm
201205	2.0×1.2×0.58mm

(3) Packaging style

T	Taping (reel)
---	---------------

(4) Inductance value

2N2	2.2nH
12N	12nH
R10	100nH

(5) Inductance tolerance

C	$\pm 0.2\text{nH}$
G	$\pm 2\%$

PACKAGING STYLE AND QUANTITIES

Packaging style	Quantity
Taping	4000 pieces/reel

Inductors

For High Frequency
SMD

NLU Series NLU2012 Type

SHAPES AND DIMENSIONS/RECOMMENDED PC BOARD PATTERN

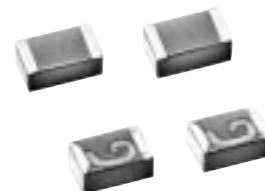
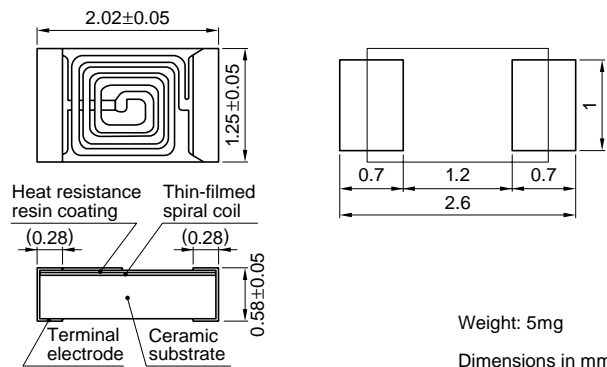

ELECTRICAL CHARACTERISTICS

Inductance (nH)	Inductance tolerance	Q		Test frequency L, Q (MHz)	Self-resonant frequency (GHz)		DC resistance (Ω)max.	Rated current (mA)max.	Part No.
		min.	typ.		min.	typ.			
1.2	±0.2nH	13	16	300	5	12.3	0.1	500	NLU201205T-1N2C
1.5	±0.2nH	17	22	300	5	10.9	0.1	500	NLU201205T-1N5C
1.8	±0.2nH	19	26	300	5	10.2	0.1	500	NLU201205T-1N8C
2.2	±0.2nH	19	28	300	5	8.5	0.11	500	NLU201205T-2N2C
2.7	±0.2nH	19	27	300	5	8.3	0.13	500	NLU201205T-2N7C
3.3	±0.2nH	19	27	300	5	7.2	0.14	500	NLU201205T-3N3C
3.9	±0.2nH	19	24	300	5	6.4	0.15	500	NLU201205T-3N9C
4.7	±0.2nH	19	24	300	4.4	5.6	0.16	500	NLU201205T-4N7C
5.6	±0.2nH	19	25	300	4.4	5.5	0.23	500	NLU201205T-5N6C
6.8	±0.2nH	19	25	300	3.8	4.8	0.25	500	NLU201205T-6N8C
8.2	±0.2nH	19	29	300	3.3	4.2	0.28	500	NLU201205T-8N2C
10	±2%	19	25	300	3	3.8	0.31	500	NLU201205T-10NG
12	±2%	19	28	300	2.8	3.6	0.47	500	NLU201205T-12NG
15	±2%	19	27	300	2.4	3.1	0.53	360	NLU201205T-15NG
18	±2%	19	28	300	2.3	2.9	0.71	260	NLU201205T-18NG
22	±2%	19	29	300	2	2.6	0.78	250	NLU201205T-22NG
27	±2%	19	28	300	1.8	2.3	0.97	250	NLU201205T-27NG
33	±2%	19	28	300	1.6	2	1.2	210	NLU201205T-33NG
39	±2%	19	26	300	1.4	1.8	1.4	180	NLU201205T-39NG
47	±2%	19	28	300	1.3	1.7	1.8	150	NLU201205T-47NG
56	±2%	19	27	300	1.2	1.6	1.9	150	NLU201205T-56NG
68	±2%	9	14	100	1	1.4	3.3	140	NLU201205T-68NG
82	±2%	9	14	100	0.9	1.3	4.2	120	NLU201205T-82NG
100	±2%	9	14	100	0.8	1.1	5.9	100	NLU201205T-R10G

- L, Q : HP4291A IMPEDANCE ANALYZER+16193A TEST FIXTURE
- SRF : HP8753C NETWORK ANALYZER Typical value : HP8719C NETWORK ANALYZER
- Rdc : MATSUSHITA DIGITAL MILLIOHM METER VP-2941A or equivalent

TYPICAL ELECTRICAL CHARACTERISTICS

Q vs. FREQUENCY CHARACTERISTICS

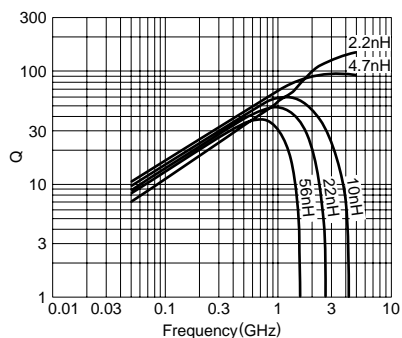

INDUCTANCE vs. FREQUENCY CHARACTERISTICS

