

BIPOLAR ANALOG INTEGRATED CIRCUIT

μ PC1945

ADJUSTABLE PRECISION SHUNT REGULATORS

DESCRIPTION

The μ PC1945 is an adjustable-shunt regulator featuring a high-precision internal reference voltage. The separate power supply pin (V_{CC} pin) allows the cathode voltage to be dropped to as low as 0.4V, making this product ideal for error amplifiers that use a low voltage (minimum 1.8 V) output switching regulator.

Support for high-density mounting is also provided through the use of a 5-pin plastic mini-mold package.

FEATURES

- Separate cathode and power supply pins
- Suitable for low voltage (minimum 1.8 V) output switching regulator
 - Cathode voltage range: 0.4 V to 5 V
 - Power supply voltage range: V_{REF} to 5 V
 - Reference voltage: 1.26 V
- 5-pin plastic mini-mold package
 - Mold dimensions: 2.9 mm(L)×1.5 mm(W)×1.1 mm(H)

ORDERING INFORMATION

Part Number	Package	Marking	Form of Shipment
μ PC1945TA	5-pin plastic mini-mold (SC-74A)	K95	–
μ PC1945TA-E1	5-pin plastic mini-mold (SC-74A)	K95	<ul style="list-style-type: none"> • Embossed taping • Pin 1 in wind-in direction • 3000 units/reel
μ PC1945TA-E2	5-pin plastic mini-mold (SC-74A)	K95	<ul style="list-style-type: none"> • Embossed taping • Pin 1 in pull-out direction • 3000 units/reel

The information in this document is subject to change without notice. Before using this document, please confirm that this is the latest version.
 Not all devices/types available in every country. Please check with local NEC representative for availability and additional information.

PIN CONNECTION (Top View)

5-pin plastic mini-mold (SC-74A)

μPC1945TA

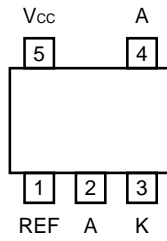

Pin No	Pin Symbol	Pin Name
1	REF	Reference
2	A	Anode
3	K	Cathode
4	A	Anode
5	V _{cc}	Supply Voltage

Caution It is recommended to connect pins 2 and 4 externally. If this is not possible, leave pin 2 open.

BLOCK DIAGRAM

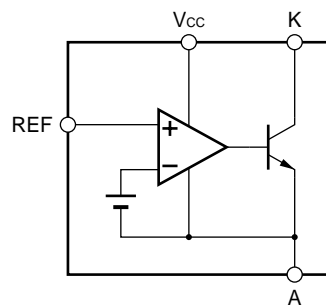

STANDARD CONNECTION

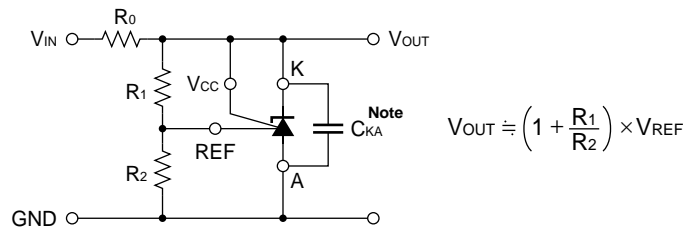

Note $C_{KA} = 100 \text{ pF}$ minimum. Connect to prevent oscillation.

Caution Supply K (Cathode) and V_{cc} from the same power supply.

Remark The μPC1945 is represented by the following symbol in this data sheet.

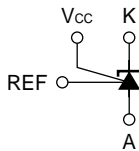

APPLICATION CIRCUIT EXAMPLE

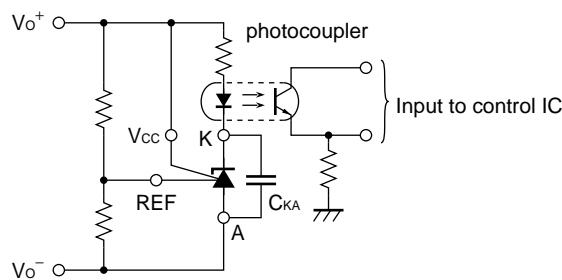

ABSOLUTE MAXIMUM RATINGS

(Unless otherwise specified, T_A = 25°C)

Parameter	Symbol	Ratings	Unit
Supply Voltage	V _{CC}	6	V
Cathode Voltage	V _K	V _{CC}	V
Cathode Current	I _K	15	mA
Cathode/Anode Reverse Current	-I _K	-5	mA
Reference Current	I _{REF}	50	μA
Reference/Anode Reverse Current	-I _{REF}	-5	mA
Circuit Current	I _{CC}	2	mA
Total Power Dissipation	P _T	90	mW
Operating Ambient Temperature	T _A	-20 to+85	°C
Operating Junction Temperature	T _J	-20 to+125	°C

Caution Product quality may suffer if the absolute maximum rating is exceeded even momentarily for any parameter. That is, the absolute maximum ratings are rated values at which the product is on the verge of suffering physical damage, and therefore the product must be used under conditions that ensure that the absolute maximum ratings are not exceeded.

RECOMMENDED OPERATING CONDITIONS

Parameter	Symbol	MIN.	TYP.	MAX.	Unit
Supply Voltage	V _{CC}	V _{REF}		5	V
Cathode Voltage	V _K	0.4		V _{CC} ^{Note}	V
Cathode Current	I _K			12	mA
Total Power Dissipation	P _T			20	mW
Operating Ambient Temperature	T _A	-20		+85	°C
Operating Junction Temperature	T _J	-20		+100	°C

Note V_K ≤ V_{CC}

Caution The recommended operating range may be exceeded without causing any problems provided that the absolute maximum ratings are not exceeded. However, if the device is operated in a way that exceeds the recommended operating conditions, the margin between the actual conditions of use and the absolute maximum ratings is small, and therefore thorough evaluation is necessary. The recommended operating conditions do not imply that the device can be used with all values at their maximum values.

ELECTRICAL SPECIFICATIONS

(Unless otherwise specified, $T_A = 25^\circ\text{C}$, $I_K = 2 \text{ mA}$ (including I_{CC}), $V_{REF} = V_{CC} = V_K$, $C_{KA} = 100 \text{ pF}$)

Parameter	Symbol	Conditions	MIN.	TYP.	MAX.	Unit
Reference Voltage	V_{REF}		1.235	1.26	1.285	V
Reference Voltage Deviation Over Temperature	$ \Delta V_{REF} $	$0^\circ\text{C} \leq T_A \leq +70^\circ\text{C}$		5	30	mV
Reference Voltage Deviation Over Supply Voltage	$ \Delta V_{REF} / \Delta V_{CC} $	$V_{REF} \leq V_K \leq 5 \text{ V}$			1.5	mV/V
Reference Input Current	I_{REF}	$R_1 = 10 \text{ k}\Omega$, $R_2 = \infty$		2	4	μA
Reference Input Current Deviation Over Temperature	$ \Delta I_{REF} $	$0^\circ\text{C} \leq T_A \leq +70^\circ\text{C}$		0.3	1.2	μA
Minimum Circuit Current	$I_{CC \text{ MIN.}}$	$\Delta V_{REF} = -2\%$		110	400	μA
Minimum Cathode Voltage	$V_{K \text{ MIN.}}$	$I_K : I_{CC} = 10 : 1$		60	400	mV
Off-state Cathode Current	$I_{K \text{ OFF}}$	$V_{CC} = V_K = 6 \text{ V}$, $V_{REF} = 0 \text{ V}$		0.01	1	μA
Dynamic Impedance	$ Z_{KA} $	$f = 1 \text{ kHz}$, $2 \text{ mA} \leq I_K \leq 12 \text{ mA}$		0.3	0.7	Ω
Unity Gain Bandwidth	f_{unity}	$R_1 = R_2 = 10 \text{ k}\Omega$		500		kHz

TYPICAL CHARACTERISTICS (Unless otherwise specified, $T_A = 25^\circ\text{C}$ Reference Values)

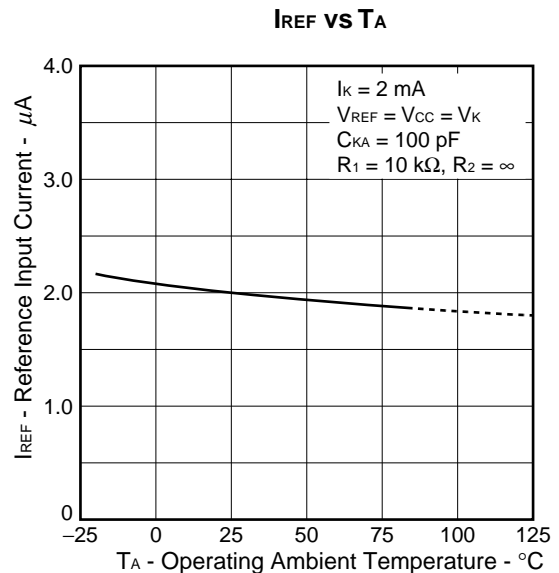
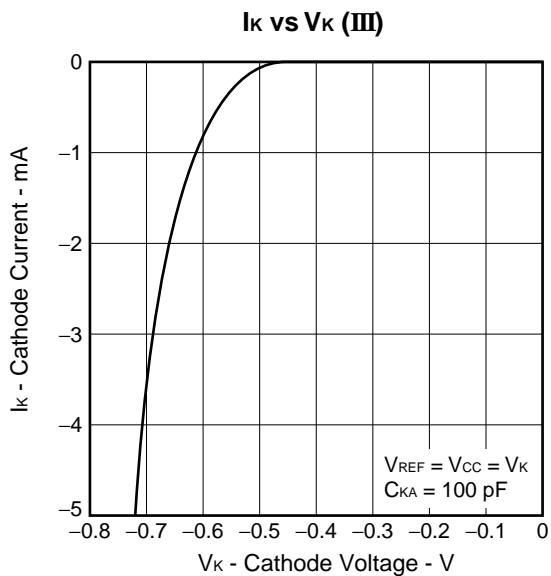
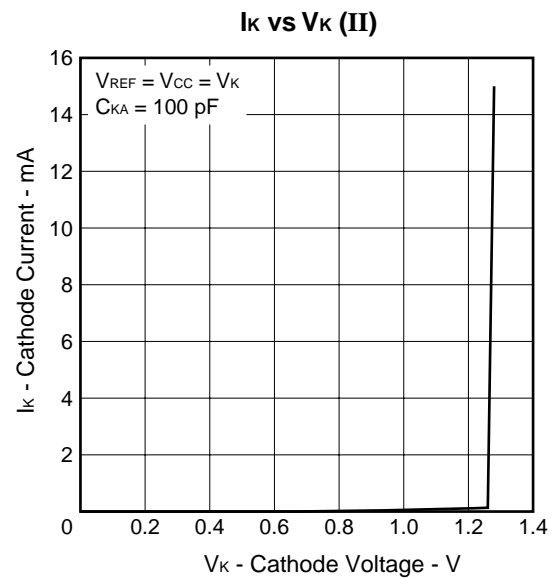
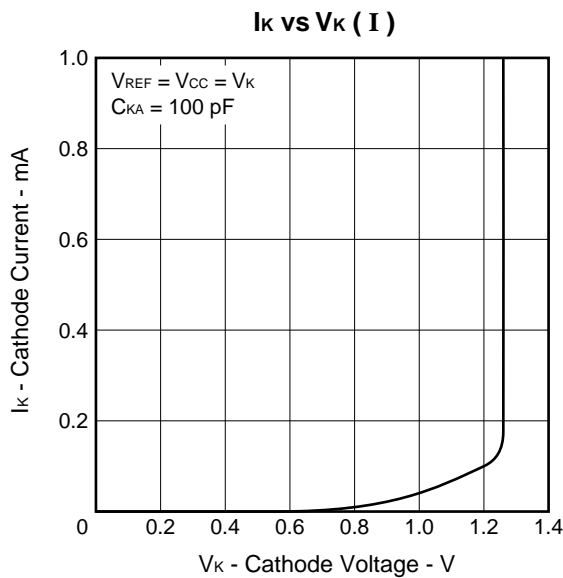
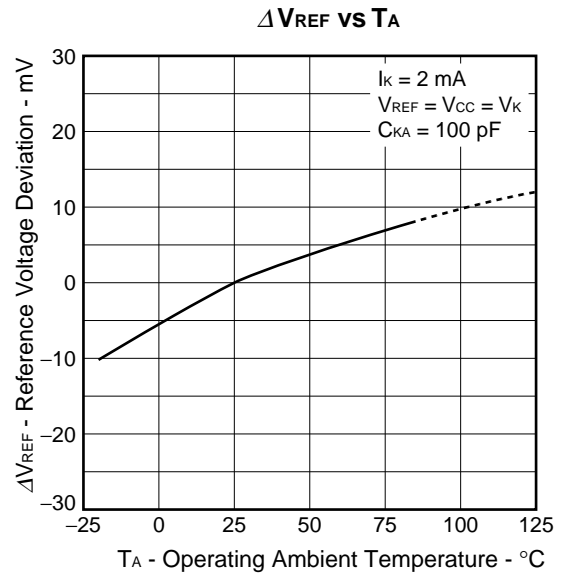
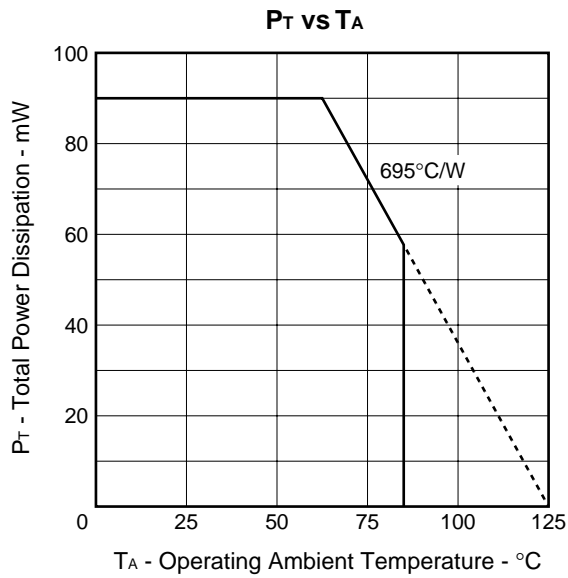

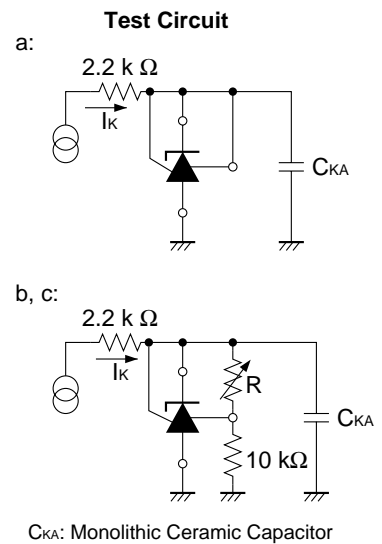
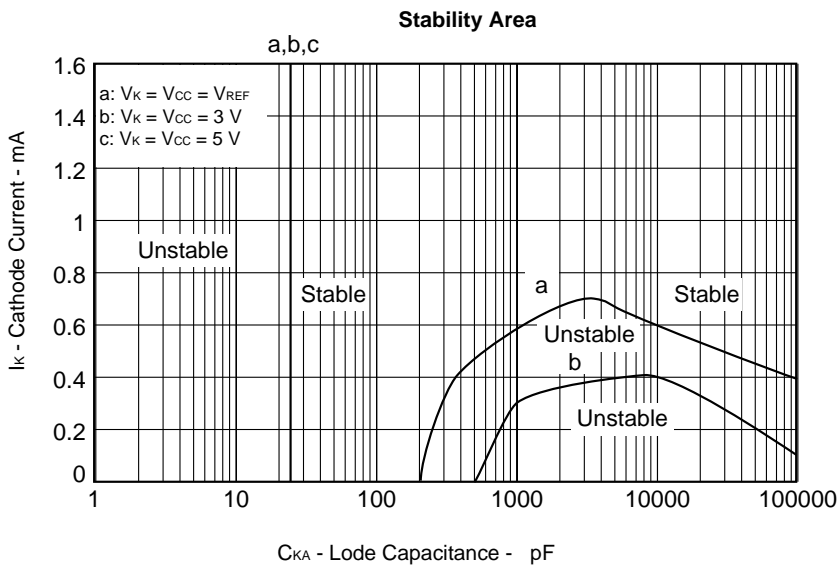
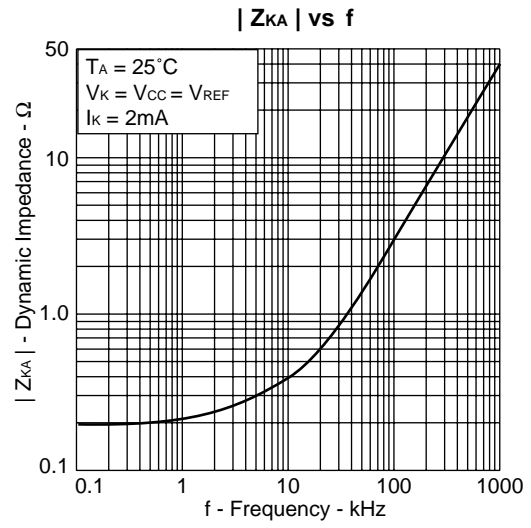
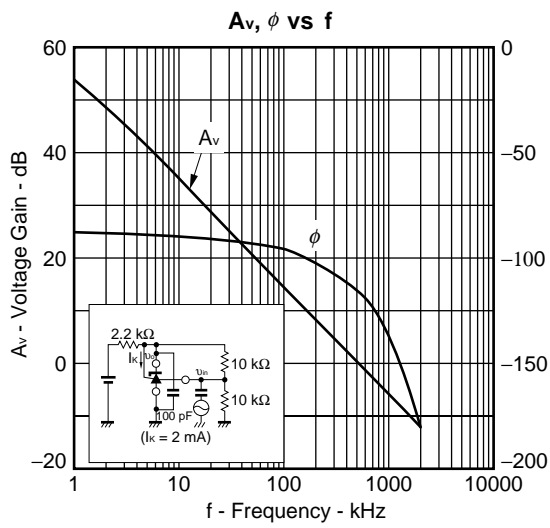

Caution of Stability Area

When using plural different types of capacitors, each capacitor is needed to be stable independently.

PACKAGE DRAWING

5 PIN PLASTIC MINI MOLD (Unit: mm)

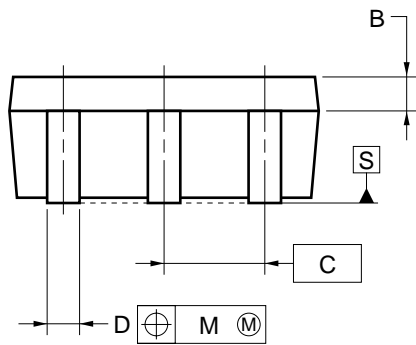
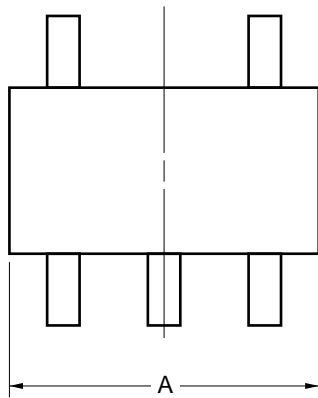

detail of lead end

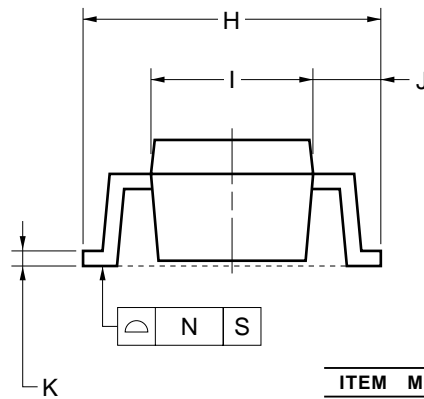
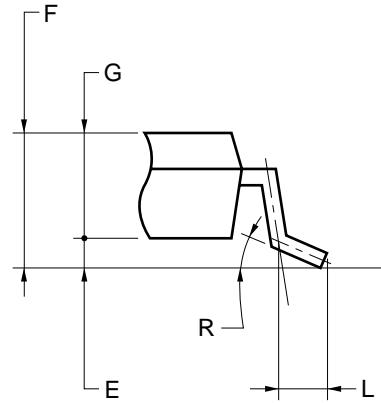

ITEM	MILLIMETERS
A	2.9±0.2
B	0.3
C	0.95 (T.P.)
D	0.32 ^{+0.05} _{-0.02}
E	0.05±0.05
F	1.4 MAX.
G	1.1 ^{+0.2} _{-0.1}
H	2.8±0.2
I	1.5 ^{+0.2} _{-0.1}
J	0.65 ^{+0.1} _{-0.15}
K	0.16 ^{+0.1} _{-0.06}
L	0.4±0.2
M	0.19
N	0.1
R	5°±5°

S5TA-95-15A

★ REFERENCE DOCUMENTS

Usage of Three-Terminal-Regulators	G12702E
Review of Quality and Reliability Handbook	C12769E
Semiconductor Device Mounting Technology Manual	C10535E

★ RECOMMENDED SOLDERING CONDITIONS

When soldering this product, it is highly recommended to observe the conditions as shown below. If other soldering processes are used, or if the soldering is performed under different conditions, please make sure to consult with our sales offices.

For more details, refer to our document “SEMICONDUCTOR DEVICE MOUNTING TECHNOLOGY MANUAL” (C10535E).

μPC1945TA: 5-pin plastic mini-mold (SC-74A)

Process	Conditions	Symbol
Infrared ray reflow	Peak temperature: 235°C or below (Package surface temperature), Reflow time: 30 seconds or less (at 210°C or higher), Maximum number of reflow processes: 3 times.	IR35-00-3
VPS	Peak temperature: 215°C or below (Package surface temperature), Reflow time: 40 seconds or less (at 200°C or higher), Maximum number of reflow processes: 3 times.	VP15-00-3
Wave soldering	Solder temperature: 260°C or below, Flow time: 10 seconds or less, Maximum number of flow processes: 1 time, Pre-heating temperature: 120°C or below (Package surface temperature).	WS60-00-1

Caution Apply only one kind of soldering condition to a device, or the device will be damaged by heat stress.

[MEMO]

[MEMO]

- **The information in this document is current as of September, 2001. The information is subject to change without notice. For actual design-in, refer to the latest publications of NEC's data sheets or data books, etc., for the most up-to-date specifications of NEC semiconductor products. Not all products and/or types are available in every country. Please check with an NEC sales representative for availability and additional information.**
- No part of this document may be copied or reproduced in any form or by any means without prior written consent of NEC. NEC assumes no responsibility for any errors that may appear in this document.
- NEC does not assume any liability for infringement of patents, copyrights or other intellectual property rights of third parties by or arising from the use of NEC semiconductor products listed in this document or any other liability arising from the use of such products. No license, express, implied or otherwise, is granted under any patents, copyrights or other intellectual property rights of NEC or others.
- Descriptions of circuits, software and other related information in this document are provided for illustrative purposes in semiconductor product operation and application examples. The incorporation of these circuits, software and information in the design of customer's equipment shall be done under the full responsibility of customer. NEC assumes no responsibility for any losses incurred by customers or third parties arising from the use of these circuits, software and information.
- While NEC endeavours to enhance the quality, reliability and safety of NEC semiconductor products, customers agree and acknowledge that the possibility of defects thereof cannot be eliminated entirely. To minimize risks of damage to property or injury (including death) to persons arising from defects in NEC semiconductor products, customers must incorporate sufficient safety measures in their design, such as redundancy, fire-containment, and anti-failure features.
- NEC semiconductor products are classified into the following three quality grades:
"Standard", "Special" and "Specific". The "Specific" quality grade applies only to semiconductor products developed based on a customer-designated "quality assurance program" for a specific application. The recommended applications of a semiconductor product depend on its quality grade, as indicated below. Customers must check the quality grade of each semiconductor product before using it in a particular application.
"Standard": Computers, office equipment, communications equipment, test and measurement equipment, audio and visual equipment, home electronic appliances, machine tools, personal electronic equipment and industrial robots
"Special": Transportation equipment (automobiles, trains, ships, etc.), traffic control systems, anti-disaster systems, anti-crime systems, safety equipment and medical equipment (not specifically designed for life support)
"Specific": Aircraft, aerospace equipment, submersible repeaters, nuclear reactor control systems, life support systems and medical equipment for life support, etc.
The quality grade of NEC semiconductor products is "Standard" unless otherwise expressly specified in NEC's data sheets or data books, etc. If customers wish to use NEC semiconductor products in applications not intended by NEC, they must contact an NEC sales representative in advance to determine NEC's willingness to support a given application.
(Note)
(1) "NEC" as used in this statement means NEC Corporation and also includes its majority-owned subsidiaries.
(2) "NEC semiconductor products" means any semiconductor product developed or manufactured by or for NEC (as defined above).