

### DUAL OPERATIONAL AMPLIFIER

- In the Linear Mode the Input Common Mode Voltage Range Includes Ground.
- Two Internally Compensated OP Amps are in Single Package.
- Low Power Dissipation and Power Drain Suitable for Battery Operation.
- Differential Input Voltage Range Equal to the Power Supply Voltage.
- Wide Power Supply Voltage Range and Signal Power Supply : Single Supply  $3V_{DC}$  to  $12V_{DC}$  Dual Supplies  $\pm 1.5V_{DC}$  to  $\pm 6V_{DC}$
- Large Output Voltage Swing :  $0V_{DC}$  to  $V_{CC}-1.5V_{DC}$
- Low Input Biasing Current :  $I_I=20nA_{DC}$  (Typ.)

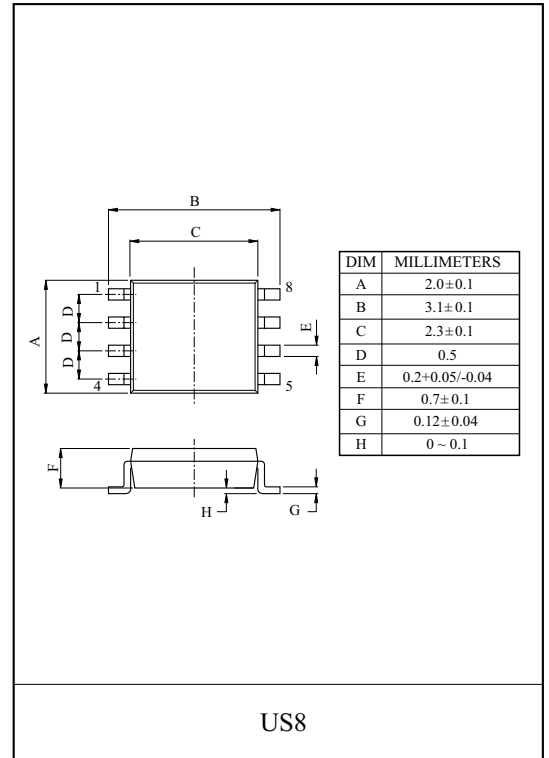

### PIN CONNECTION (TOP VIEW)

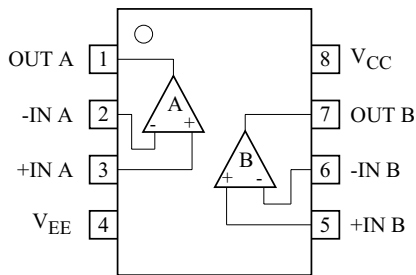

### MARKING

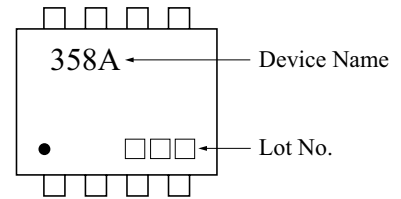

### EQUIVALENT CIRCUIT

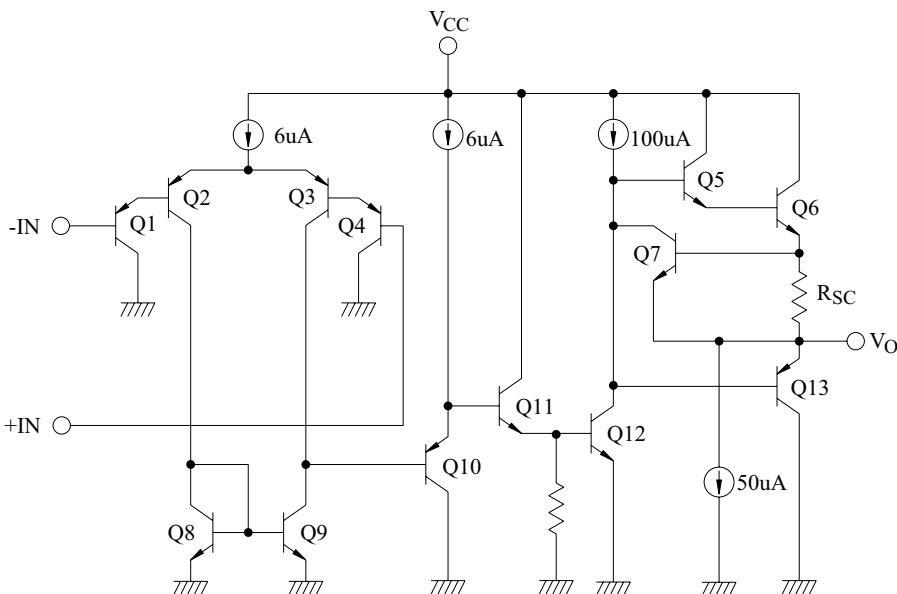

# KIA358AFK

## MAXIMUM RATINGS (Ta=25 °C)

CHARACTERISTIC	SYMBOL	RATING	UNIT
Supply Voltage	V <sub>CC</sub>	12, +6	V
	V <sub>EE</sub>	0, -6	
Differential Input Voltage	DV <sub>IN</sub>	±12	V
Input Voltage	V <sub>IN</sub>	-0.3 ~12	V
Power Dissipation	P <sub>D</sub>	200	mW
Operating Temperature	T <sub>opr</sub>	-40 ~85	°C
Storage Temperature	T <sub>stg</sub>	-55 ~125	°C

## ELECTRICAL CHARACTERISTICS (V<sub>CC</sub>=5V, V<sub>EE</sub>=GND, Ta=25 °C)

CHARACTERISTIC	SYMBOL	TEST CONDITION	MIN.	TYP.	MAX.	UNIT
Input Offset Voltage	V <sub>IO</sub>	R <sub>g</sub> ≤ 10k Ω	-	2	7	mV
Input Offset Current	I <sub>IO</sub>	-	-	5	30	nA
Input Bias Current	I <sub>I</sub>	-	-	45	150	nA
Common Mode Input Voltage	CMV <sub>IN</sub>	V <sub>CC</sub> =12V, V <sub>EE</sub> =GND	0	-	V <sub>CC</sub> -1.5	V
Supply Current	I <sub>CC</sub> , I <sub>EE</sub>	R <sub>L</sub> =∞, All OP Amps	-	0.7	1.2	mA
Voltage Gain	G <sub>V</sub>	R <sub>L</sub> ≥ 2k Ω	86	100	-	dB
Maximum Output Voltage Swing	V <sub>OP-P</sub>	R <sub>L</sub> =2k Ω	0	V <sub>CC</sub> -1.5	-	V
Common Mode Input Signal Rejection Ratio	CMRR	-	60	85	-	dB
Supply Voltage Rejection Ratio	SVRR	R <sub>g</sub> =10k Ω	60	100	-	dB
Source Current	I <sub>source</sub>	-IN=0V <sub>DC</sub> , +IN=1V <sub>DC</sub>	10	30	-	mA
Sink Current	I <sub>sink</sub>	-IN=1V <sub>DC</sub> , +IN=0V <sub>DC</sub>	10	20	-	mA

# KIA358AFK

$V_{CC} - I_{CC}$

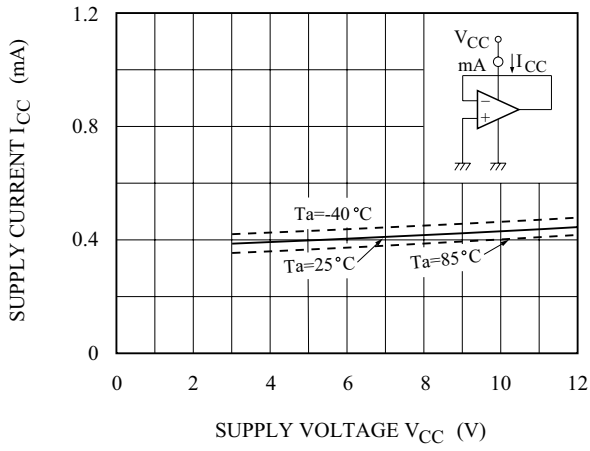

$V_{CC} - I_I$

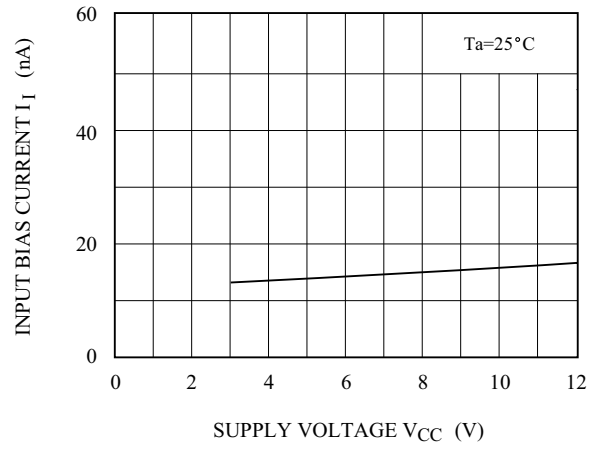

$V_{CC} - G_V$

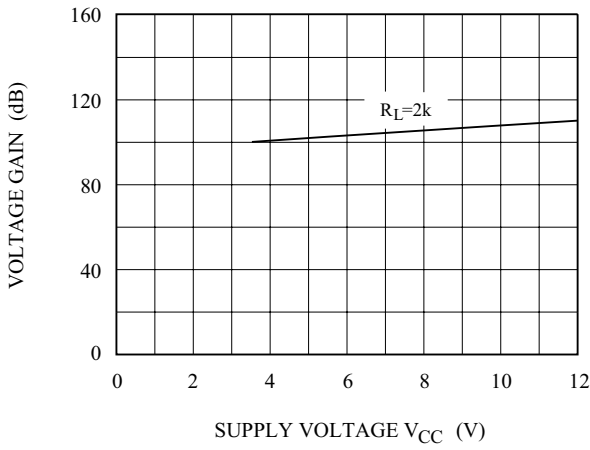

$I_{SOURCE} - T_a$

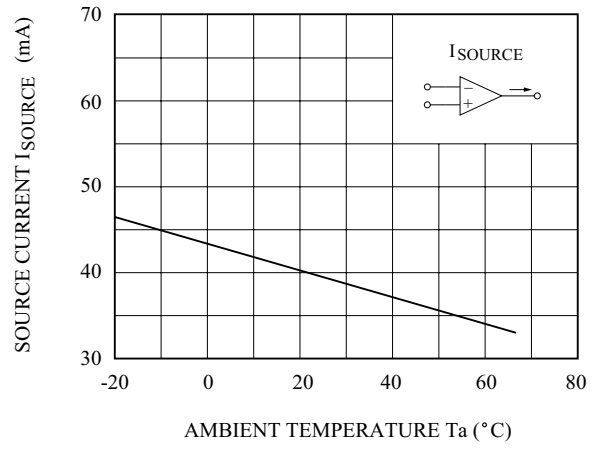

CMRR - f

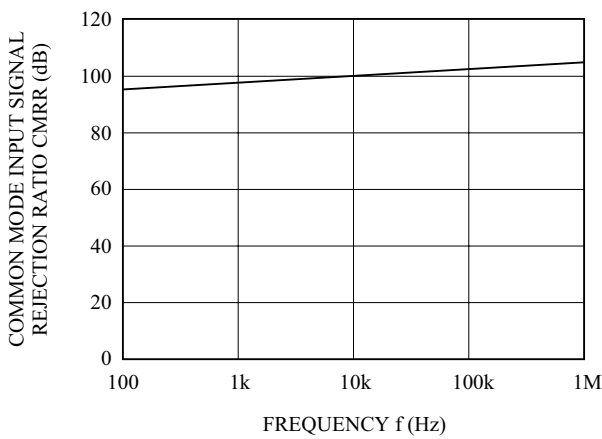

$G_V - f$

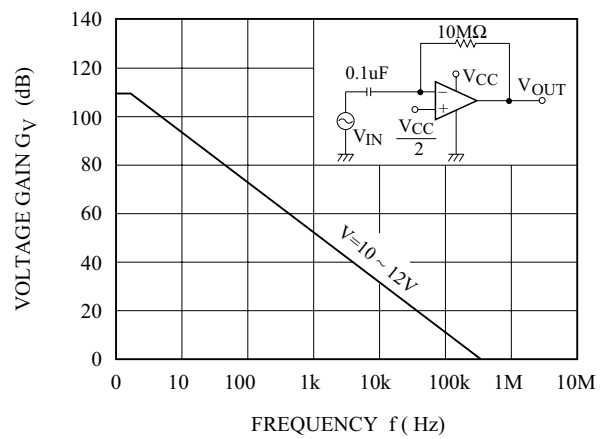

# KIA358AFK

