

1.03 V REGULATOR WITH ON/OFF SWITCH

FEATURES

- Low Input Voltage Operation (Single Battery Cell)
- Internal PNP Transistor
- Internal Shutdown Control (Off Current, 0.1 μ A max)
- Low Dropout Voltage [30 mV (typ.) at 2 mA]
- Miniature Package (SOT-26)
- Very Low Noise

APPLICATIONS

- Pagers
- Personal Communication Equipment
- Portable Consumer Equipment
- Radio Control Systems
- Single Battery Cell Systems

DESCRIPTION

TK70403 is a low dropout, linear regulator with a built-in electronic switch. A pin for a bypass capacitor is provided, which connects to the internal circuitry to lower the overall output noise level.

An internal PNP pass-transistor is used in order to achieve low dropout voltage (typically 30 mV at 2 mA load current). This makes it possible to maintain a stable output voltage as the battery voltage decreases, extending the useful battery life.

The TK70403 is available in a miniature SOT-26 surface mount package.

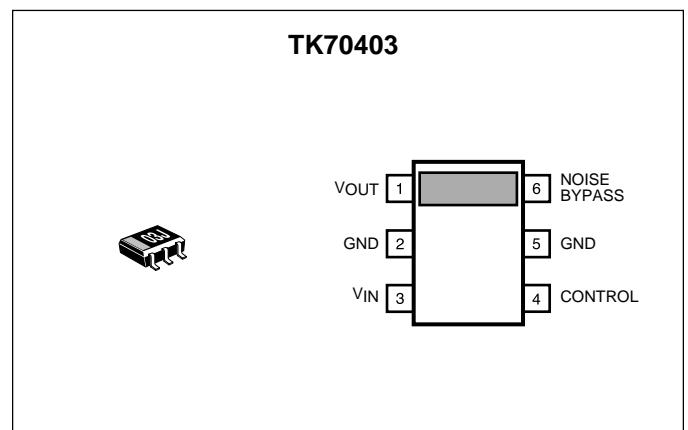

ORDERING INFORMATION

TK70403MTB

└─ Tape/Reel Code

TAPE/REEL CODE
TB: Tape Left

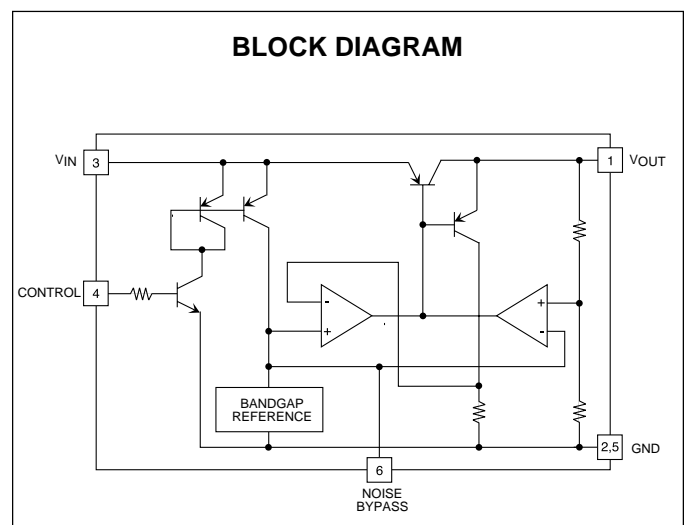

TK70403

ABSOLUTE MAXIMUM RATINGS

Supply Voltage	6 V	Operating Temperature Range	-10 to +60 °C
Power Dissipation (Note 1)	350 mW	Operating Voltage Range	0.9 to 5.0 V
Junction Temperature	150 °C	Lead Soldering Temperature (10 s)	235 °C
Storage Temperature Range	-55 to +150 °C		

TK70403 ELECTRICAL CHARACTERISTICS

Test Conditions: $V_{IN} = 1.4 \text{ V}$, $T_A = 25 \text{ °C}$, $R_{CONT} = 820 \text{ K}\Omega$, unless otherwise specified.

SYMBOL	PARAMETER	TEST CONDITIONS	MIN	TYP	MAX	UNITS
I_{STBY}	Standby Current	$V_{IN} = 1.4 \text{ V}$, Output OFF			0.1	μA
V_{OUT}	Output Voltage	$I_{OUT} = 2 \text{ mA}$	0.98	1.03	1.065	V
V_{DROP}	Dropout Voltage	$I_{OUT} = 2 \text{ mA}$			0.06	V
I_{OUT}	Output Current	(Note 2)	10	50		mA
I_Q	Quiescent Current	$I_{OUT} = 0 \text{ mA}$, Excluding I_{CONT}			150	μA
Line Reg	Line Regulation	$V_{IN} = 1.43 \text{ to } 1.7 \text{ V}$			20	mV
Load Reg	Load Regulation	$I_{OUT} = 0.1 \text{ to } 5.0 \text{ mA}$			20	mV
$\Delta V_{OUT}/\Delta T$	Temperature Coefficient	$I_{OUT} = 2 \text{ mA}$		0.25		$\text{mV}/\text{°C}$
V_{ref}	Reference Voltage		0.4			V
CONTROL TERMINAL SPECIFICATIONS: $R_{CONT} = 820 \text{ K}\Omega$						
I_{CONT}	Control Terminal Current	$V_{CONT} = 1.0 \text{ V}$, Output ON			1.0	μA
$V_{CONT(ON)}$	Control Voltage (ON)	Output ON	0.85			V
$V_{CONT(OFF)}$	Control Voltage (OFF)	Output OFF	0		0.3	V

Note 1: Power dissipation is 350 mW when mounted as recommended. Derate at 2.8 mW/°C for operation above 25 °C.

Note 2: I_{OUT} when V_{OUT} drops 0.4 V from $V_{OUT(TYP)}$.

Gen Note: Ripple rejection and noise voltage are affected by the value and characteristics of the capacitor used. Example: Ripple rejection is 48 dB at $C_L = 1 \mu\text{F}$, $C_N = 0.1 \mu\text{F}$, $I_{OUT} = 2 \text{ mA}$, $f = 400 \text{ Hz}$.

Gen Note: Parameters with min. or max. values are 100% tested at $T_A = 25 \text{ °C}$.

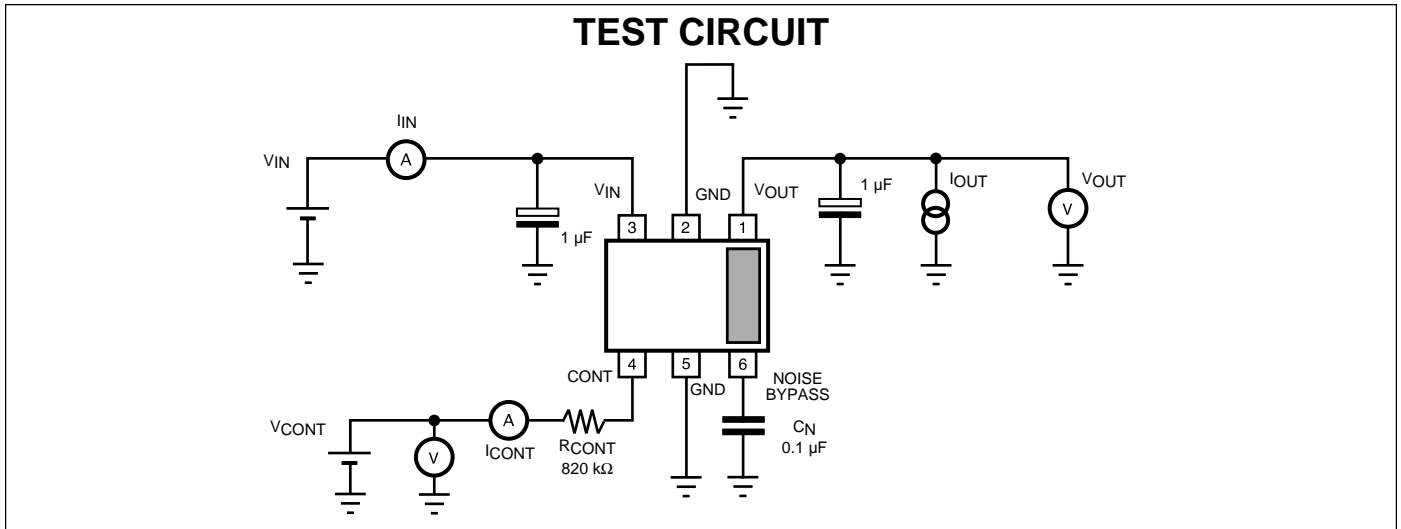

TYPICAL PERFORMANCE CHARACTERISTICS

$T_A = 25\text{ }^\circ\text{C}$, unless otherwise specified.

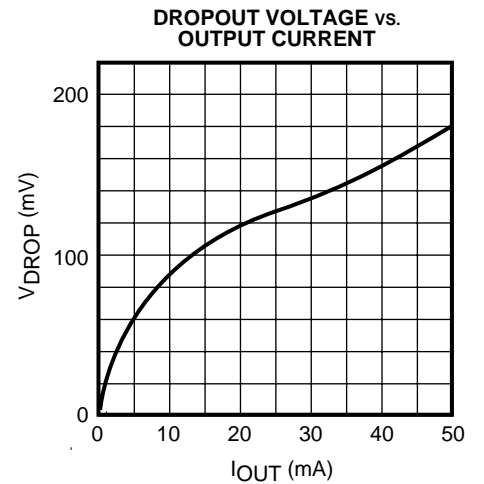
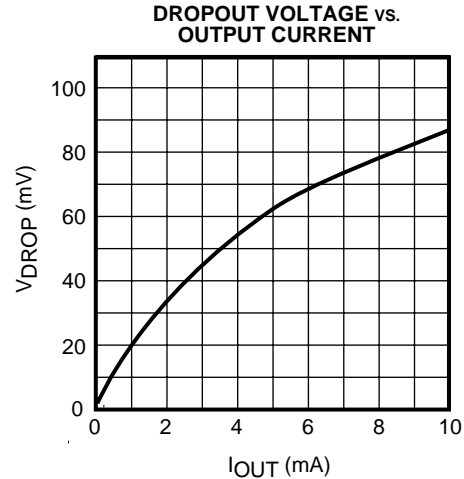
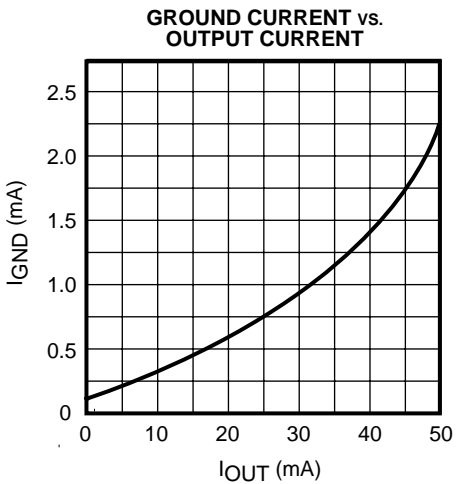
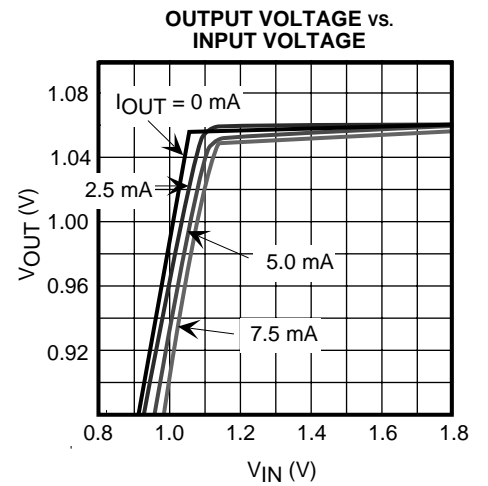
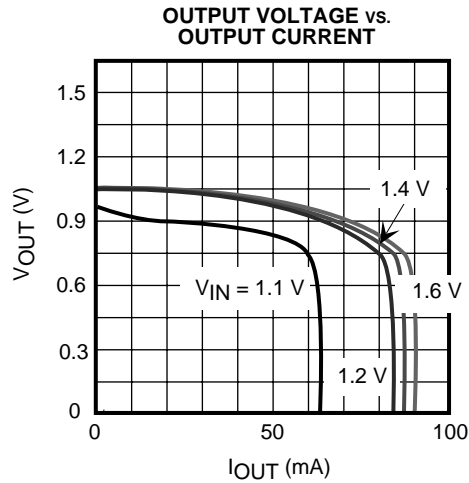
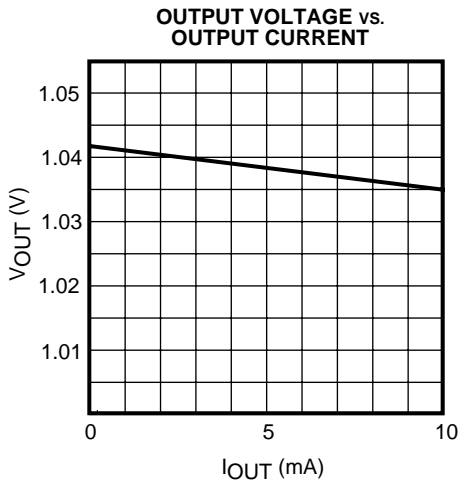

TYPICAL PERFORMANCE CHARACTERISTICS (CONT.)

$T_A = 25\text{ }^\circ\text{C}$, unless otherwise specified.

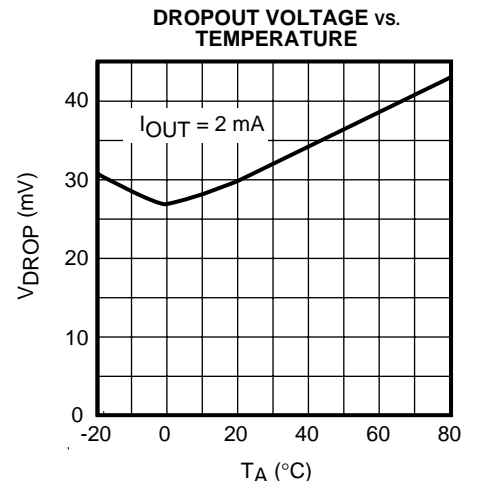
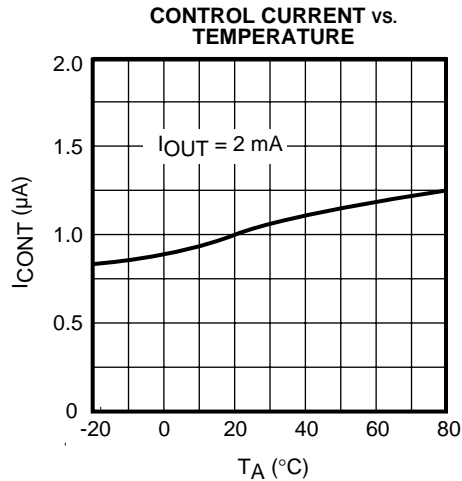
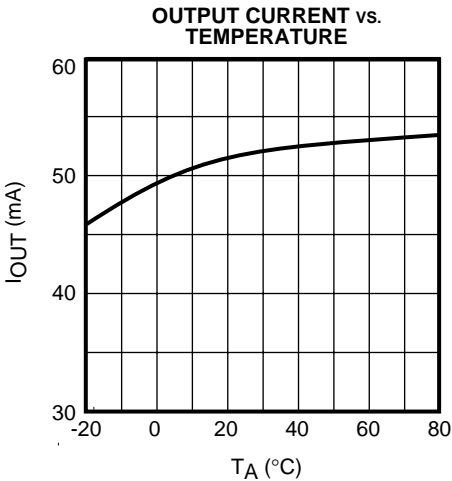
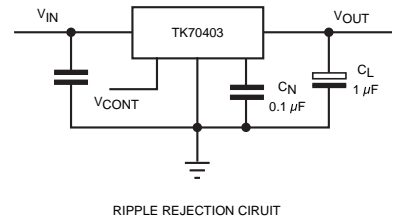
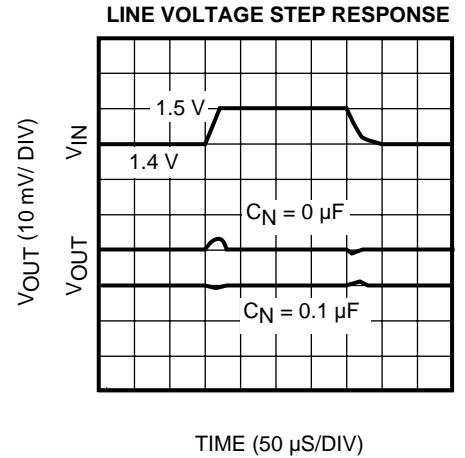
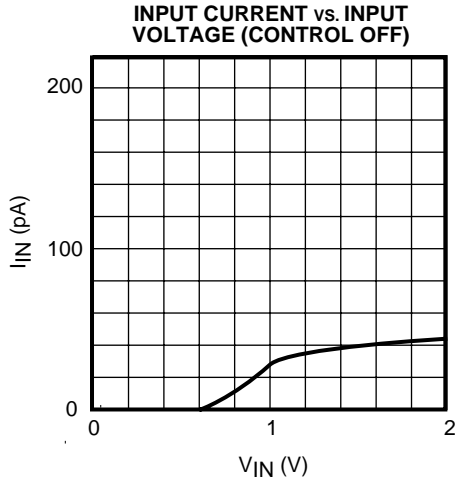
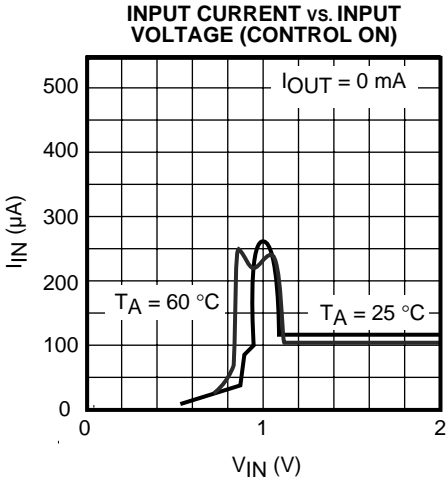

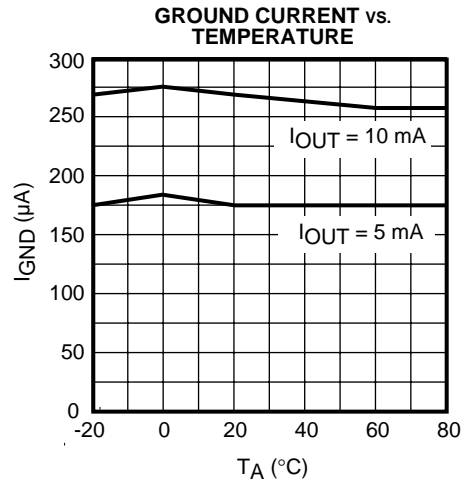
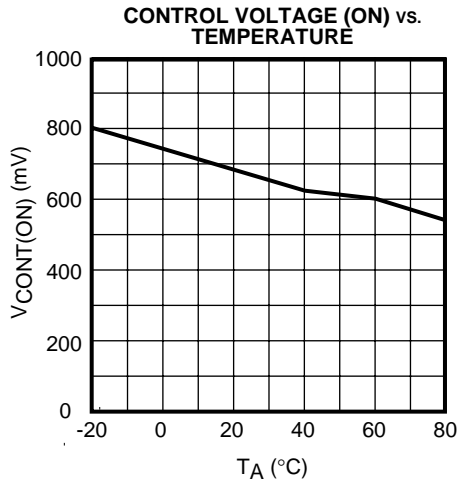
TYPICAL PERFORMANCE CHARACTERISTICS (CONT.) $T_A = 25\text{ }^\circ\text{C}$, unless otherwise specified.

DEFINITION AND EXPLANATION OF TECHNICAL TERMS

OUTPUT VOLTAGE (V_{OUT})

The output voltage is specified with $V_{IN} = V_{OUT(TYP)} + 0.4$ and $I_{OUT} = 2$ mA.

DROPOUT VOLTAGE (V_{DROP})

The dropout voltage is the difference between the input voltage and the output voltage, at which point the regulator starts to fall out of regulation. Below this value, the output voltage will fall as the input value is reduced. It is dependent upon the load current and the temperature.

OUTPUT CURRENT ($I_{OUT(MAX)}$)

The rated output current is specified under the condition where the output voltage drops 0.4 V when the output current is loaded. The input voltage is set to $V_{OUT} + 0.4$ V.

LINE REGULATION (Line Reg)

Line regulation is the ability of the regulator to maintain a constant output voltage as the input voltage changes. The voltage is pulsed to minimize temperature effects.

LOAD REGULATION (Load Reg)

Load regulation is the ability of the regulator to maintain a constant output voltage as the load current changes. It is pulsed to minimize temperature effects. The load regulation is specified to 0.1 mA to 5.0 mA.

QUIESCENT CURRENT (I_Q)

The quiescent current is the current which flows through the ground terminal under no load conditions ($I_{OUT} = 0$ mA).

GROUND CURRENT (I_{GND})

Ground current is the current which flows through the ground pin(s). It is defined as $I_{IN} - I_{OUT}$, excluding control current.

RIPPLE REJECTION (RR)

Ripple rejection is the ability of the regulator to attenuate the ripple content of the input voltage at the output. It is specified with 50 mVp-p, 400 Hz, $I_{OUT} = 2$ mA superimposed on the input voltage, where $V_{IN} = V_{OUT(TYP)} + 0.4$ V. The ripple rejection is the ratio of the output vs. input and is expressed in dB.

ON/OFF CONTROL

High is "on" (referenced to ground). When the on/off function is not used, connect the control terminal to V_{IN} . The control current can be reduced by inserting a series resistor (R_{CONT}) between the control terminal and V_{IN} . Changes in the on/off level, due to this connection, are shown below.

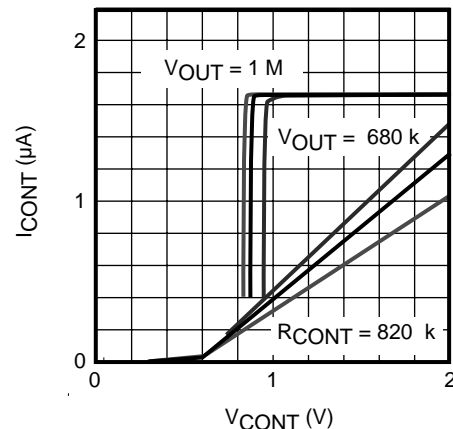

ON/OFF RESPONSE WITH CONTROL (SPEED)

The turn-on time depends upon the value of the output capacitor and the noise bypass capacitor. The turn-on time will decrease with smaller value of either capacitor. The graph below shows the relationship between turn-on time and load capacitance. However, when the capacitance is small, load transient and line transient will worsen and the noise will increase. $C_L = 0.68$ μF , $C_N = 1000$ pF will be the best for fastest operation.

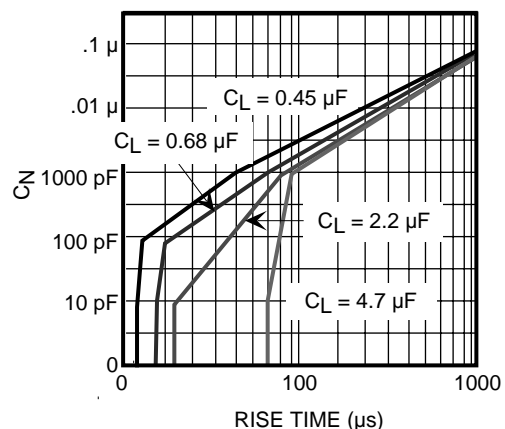

DEFINITION AND EXPLANATION OF TECHNICAL TERMS (CONT.)

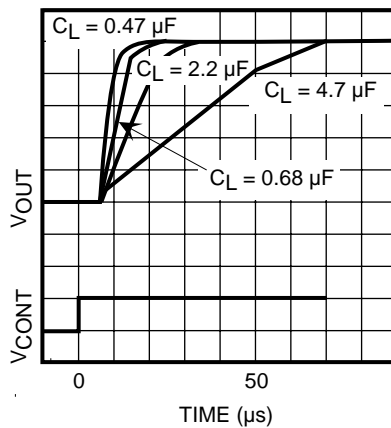

REDUCTION OF OUTPUT NOISE

Although the architecture of the Toko regulators is designed to minimize semiconductor noise, further reduction can be achieved by increasing the size of the output capacitor. A more effective solution would be to add a capacitor to the noise bypass terminal. The value of the capacitor should be at least $0.1 \mu\text{F}$ or higher (higher values provide greater noise reduction). Although stable operation is possible without the noise bypass capacitor, this terminal has a high impedance and care should be taken to avoid a large circuit area on the printed circuit board when the capacitor is not used. Please note that several parameters are affected by the value of the capacitors and bench testing is recommended when deviating from standard values.

INPUT AND OUTPUT CAPACITORS

Toko regulators require an output capacitor in order to maintain regulator loop stability. The capacitor value should be at least $0.68 \mu\text{F}$ over actual ambient operating temperature.

PACKAGE POWER DISSIPATION (P_D)

This is the power dissipation level at which the thermal sensor is activated. The IC contains an internal thermal sensor which monitors the junction temperature. When the junction temperature exceeds the monitor threshold of 150°C , the IC is shut down. The junction temperature rises as the difference between the input power ($V_{IN} \times I_{IN}$) and the output power ($V_{OUT} \times I_{OUT}$) increases. The rate of temperature rise is greatly affected by the mounting pad configuration on the PCB, the board material, and the ambient temperature. When the IC mounting has good

thermal conductivity, the junction temperature will be low even if the power dissipation is great. When mounted on the recommended mounting pad, the power dissipation of the SOT-26 is increased to 350 mW. For operation at ambient temperatures over 25°C , the power dissipation of the SOT-26 device should be derated at $2.8 \text{ mW}/^\circ\text{C}$. To determine the power dissipation for shutdown when mounted, attach the device on the actual PCB and deliberately increase the output current (or raise the input voltage) until the thermal protection circuit is activated. Calculate the power dissipation of the device by subtracting the output power from the input power. These measurements should allow for the ambient temperature of the PCB. The value obtained from $P_D / (150^\circ\text{C} - T_A)$ is the derating factor. The PCB mounting pad should provide maximum thermal conductivity in order to maintain low device temperatures. As a general rule, the lower the temperature, the better the reliability of the device. The thermal resistance when mounted is expressed as follows:

$$T_j = \theta_{jA} \times P_D + T_A$$

For Toko ICs, the internal limit for junction temperature is 150°C . If the ambient temperature (T_A) is 25°C , then:

$$150^\circ\text{C} = \theta_{jA} \times P_D + 25^\circ\text{C}$$

$$\theta_{jA} = 125^\circ\text{C} / P_D$$

P_D is the value when the thermal sensor is activated. A simple way to determine P_D is to calculate $V_{IN} \times I_{IN}$ when the output side is shorted. Input current gradually falls as temperature rises. You should use the value when thermal equilibrium is reached.

DEFINITION AND EXPLANATION OF TECHNICAL TERMS (CONT.)

The range of usable currents can also be found from the graph below.

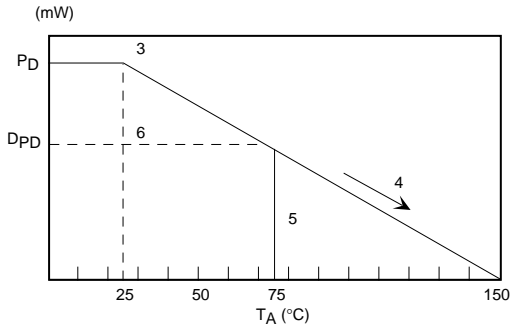

Procedure:

- 1) Find P_D
- 2) P_{D1} is taken to be $P_D \times (\sim 0.8 - 0.9)$
- 3) Plot P_{D1} against 25°C
- 4) Connect P_{D1} to the point corresponding to the 150°C with a straight line.
- 5) In design, take a vertical line from the maximum operating temperature (e.g., 75°C) to the derating curve.
- 6) Read off the value of P_D against the point at which the vertical line intersects the derating curve. This is taken as the maximum power dissipation, D_{PD} .

The maximum operating current is:

$$I_{OUT} = (D_{PD} / (V_{IN(MAX)} - V_{OUT}))$$

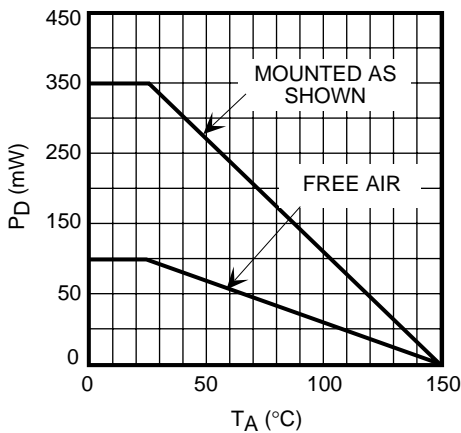

SOT-26 POWER DISSIPATION CURVE

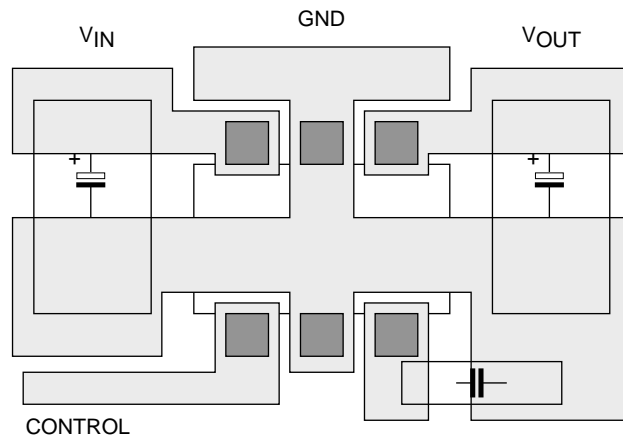
APPLICATION INFORMATION**BOARD LAYOUT****SOT-26 BOARD LAYOUT**

PACKAGE OUTLINE

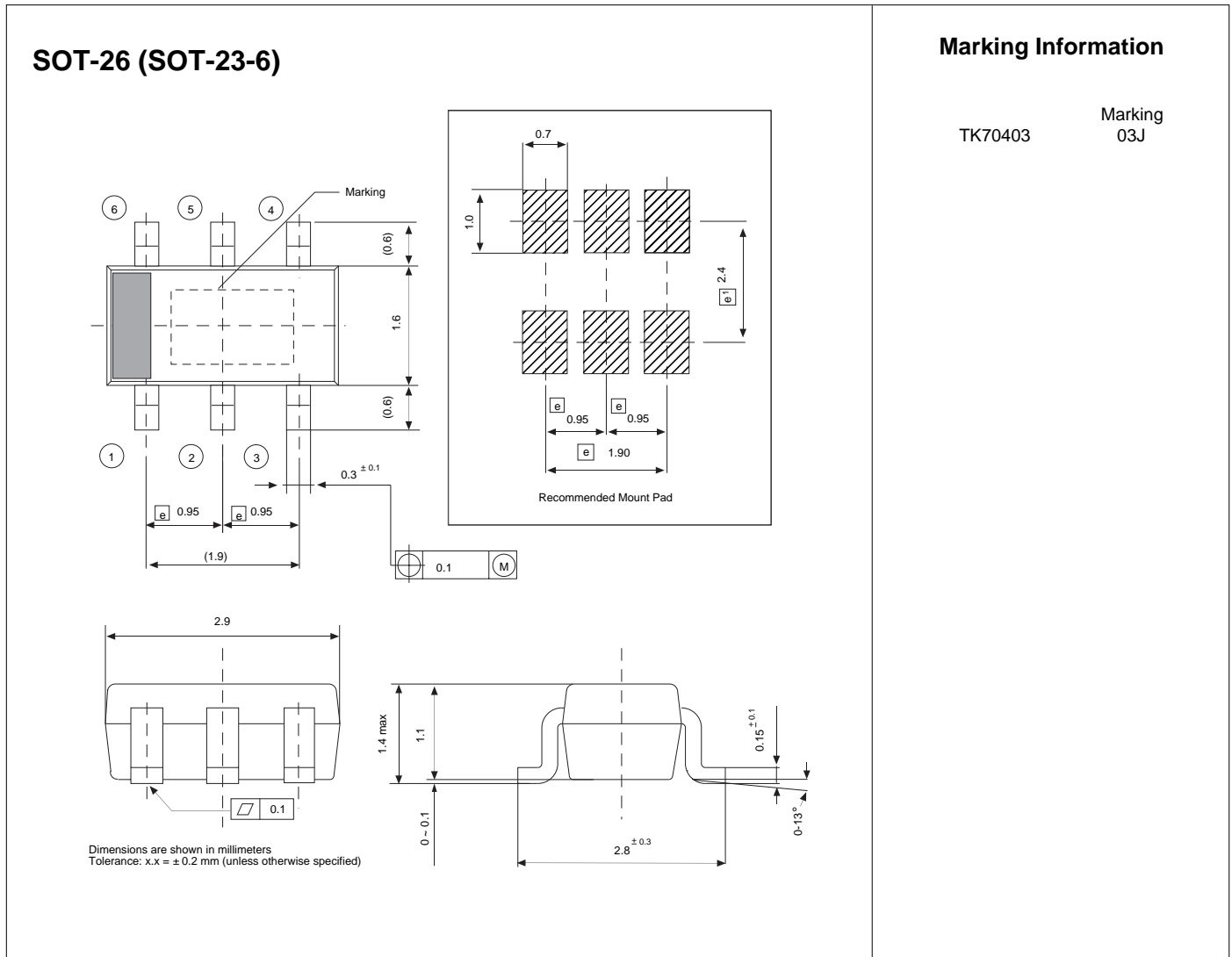

Marking Information

TK70403 Marking
03J



Toko America, Inc. Headquarters
1250 Feehanville Drive, Mount Prospect, Illinois 60056
Tel: (847) 297-0070 Fax: (847) 699-7864

TOKO AMERICA REGIONAL OFFICES

Midwest Regional Office
Toko America, Inc.
1250 Feehanville Drive
Mount Prospect, IL 60056
Tel: (847) 297-0070
Fax: (847) 699-7864

Western Regional Office
Toko America, Inc.
2480 North First Street, Suite 260
San Jose, CA 95131
Tel: (408) 432-8281
Fax: (408) 943-9790

Eastern Regional Office
Toko America, Inc.
107 Mill Plain Road
Danbury, CT 06811
Tel: (203) 748-6871
Fax: (203) 797-1223

Semiconductor Technical Support
Toko Design Center
4755 Forge Road
Colorado Springs, CO 80907
Tel: (719) 528-2200
Fax: (719) 528-2375

Visit our Internet site at <http://www.tokoam.com>

The information furnished by TOKO, Inc. is believed to be accurate and reliable. However, TOKO reserves the right to make changes or improvements in the design, specification or manufacture of its products without further notice. TOKO does not assume any liability arising from the application or use of any product or circuit described herein, nor for any infringements of patents or other rights of third parties which may result from the use of its products. No license is granted by implication or otherwise under any patent or patent rights of TOKO, Inc.