

**POSITIVE TO NEGATIVE DC TO DC CONTROLLER**  
**PRODUCT DATASHEET**

**FEATURES**

- Generate Negative Output from +5V Input
- 1A Maximum Output Current
- 1.5MHz maximum Switching Frequency
- Few External Components
- Available in 6-Pin SOT-23

**APPLICATIONS**

- Hard Disk Drives
- Blue Laser for DVD R-W
- MR Head Bias
- LCD Bias
- GaAs FET Bias
- Positive-to-Negative Conversion

**DESCRIPTION**

The IRU3065 controller is designed to provide solutions for the applications requiring low power on board switching regulators. The IRU3065 is specifically designed for positive to negative conversion and uses few components for a simple solution. The IRU3065 operates at high switching frequency (up to 1.5MHz), resulting in smaller magnetics. The output voltage can be set by using an external resistor divider. The stability over all conditions is inherent with this architecture without any compensation. The device is available in the standard 6-Pin SOT-23.

**TYPICAL APPLICATION**

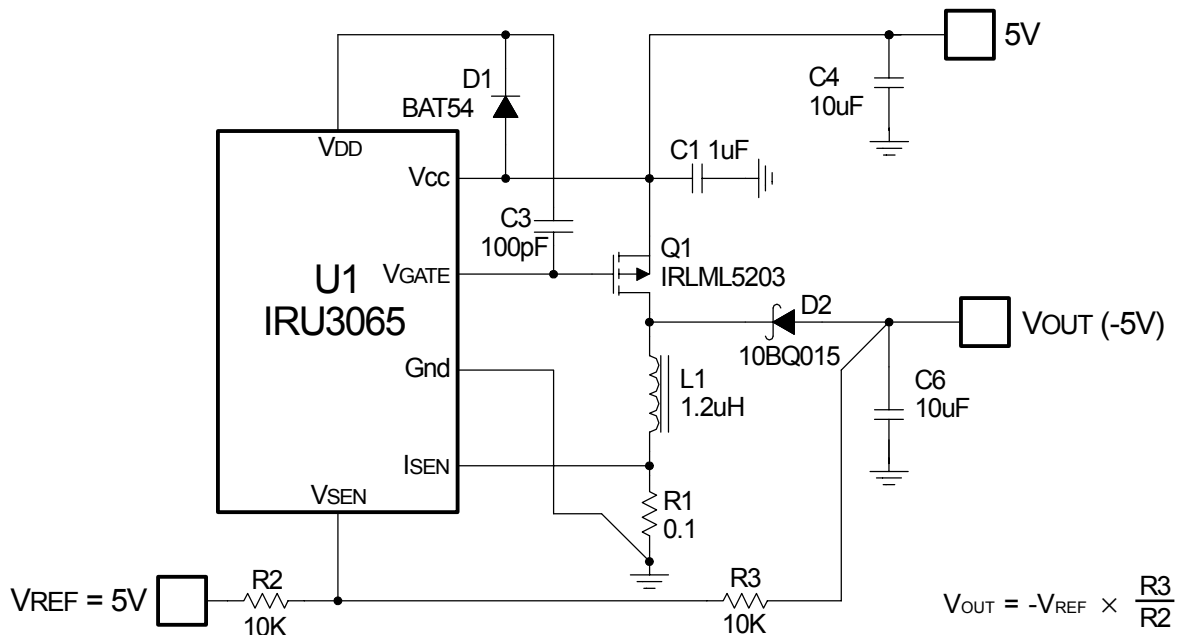

Figure 1 - Typical application of IRU3065 for single input voltage.

**PACKAGE ORDER INFORMATION**

**Basic Part (Non Lead-Free)**

T <sub>A</sub> (°C)	DEVICE	PACKAGE	OUTPUT VOLTAGE
0 To 70	IRU3065CLTR	6-Pin SOT-23 (L6)	Adjustable

**Lead-Free Part**

T <sub>A</sub> (°C)	DEVICE	PACKAGE	OUTPUT VOLTAGE
0 To 70	IRU3065CLTRPbF	6-Pin SOT-23 (L6)	Adjustable

## ABSOLUTE MAXIMUM RATINGS

V <sub>CC</sub> .....	7V
V <sub>DD</sub> .....	12V
Operating Junction Temperature Range .....	0°C To 125°C
Operating Ambient Temperature Range .....	0°C To 70°C
Storage Temperature Range .....	-65°C To +150°C
ESD Capability (Human Body Model) .....	2000V

## PACKAGE INFORMATION

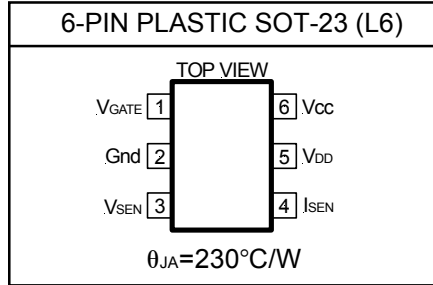

## ELECTRICAL SPECIFICATIONS

Unless otherwise specified, these specifications apply over V<sub>CC</sub>=5V, V<sub>DD</sub>=7V, C<sub>GATE</sub>=470pF, R<sub>SEN</sub>=0.125Ω, R<sub>FDBK1</sub>=R<sub>FDBK2</sub>=10KΩ (to V<sub>CC</sub>), f<sub>s</sub>=1.2MHz, I<sub>FL</sub>=0.25A and T<sub>J</sub>=0°C to 125°C. Typical values refer to T<sub>J</sub>=25°C.

PARAMETER	SYM	TEST CONDITION	MIN	TYP	MAX	UNITS
Recommended V <sub>CC</sub> Supply	V <sub>CC</sub>	Note.1	4	5		V
Recommended V <sub>DD</sub> Supply	V <sub>DD</sub>		4			V
Operating Current	I <sub>CC</sub>			3		mA
Initial Output Voltage Accuracy		Measured in application T <sub>J</sub> =25°C, V <sub>out</sub> =-5V	-1%		1%	
Output Accuracy		Measured in application over temp. V <sub>out</sub> =-5V.	-2%		+2%	
Voltage Feedback Sense	V <sub>VSEN</sub>			0		V
Voltage Feedback Input Offset	V <sub>Voff</sub>		-10		10	mV
Voltage Feedback Bias Current	I <sub>VBIAS</sub>				2	μA
Peak Current Sense Voltage	V <sub>Is</sub>			145		mV
Min Current Sense Voltage	V <sub>Is</sub>			50		mV
Current Sense Bias Current	I <sub>IBIAS</sub>				2	μA
<b>Output Drivers Section</b>						
Switching Frequency	f <sub>s</sub>	Note. 1			1.5	MHz
Max Output Duty Cycle	D <sub>max</sub>		100			%
Min Output Duty Cycle	D <sub>min</sub>				0	%
Rise Time	T <sub>r</sub>	10% to 90% V <sub>gate</sub> high		40		ns
Fall Time	T <sub>f</sub>	90% to 10% V <sub>gate</sub> going low		40		ns
Propagation Delay from Current Sense to Output	T <sub>D</sub>	V <sub>sens</sub> =1V. I <sub>sens</sub> from 0 to 250mV. Delay time between 90% of I <sub>sens</sub> to 10% of V <sub>gate</sub>		100		ns

Note. 1. guaranteed by design

**PIN DESCRIPTIONS**

PIN#	PIN SYMBOL	PIN DESCRIPTION
1	V <sub>GATE</sub>	Output driver for external P Channel MOSFET.
2	Gnd	This pin serves as ground pin and must be connected to the ground plane.
3	V <sub>SEN</sub>	A resistor divider from this pin to V <sub>OUT</sub> and V <sub>CC</sub> or an external V <sub>REF</sub> , sets the output voltage.
4	I <sub>SEN</sub>	This pin sets the maximum load current by sensing the inductor current.
5	V <sub>DD</sub>	This pin provides biasing for the output driver.
6	V <sub>CC</sub>	This pin provides biasing for the internal blocks of the IC.

**BLOCK DIAGRAM**

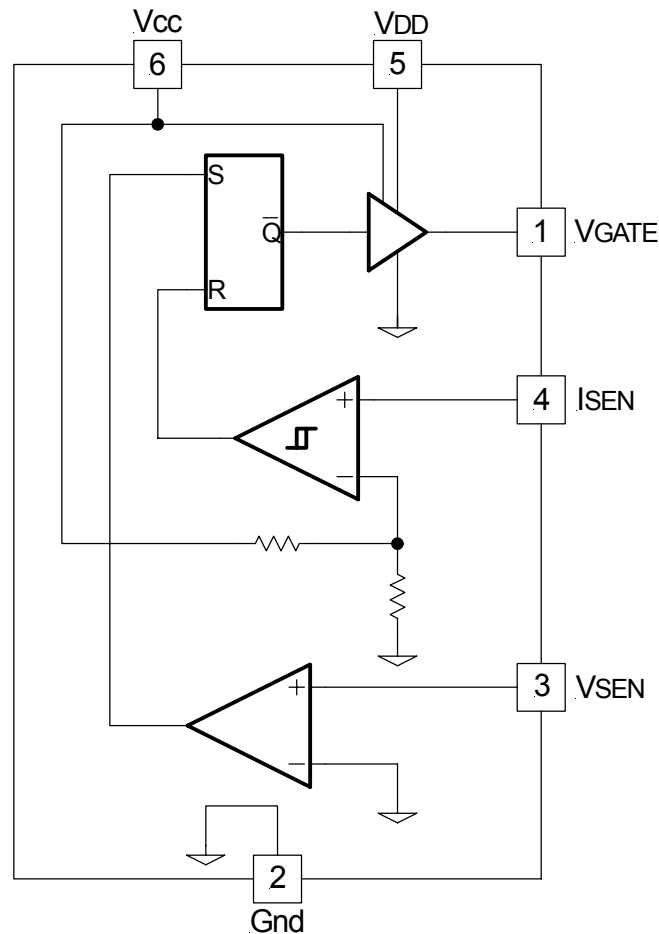

Figure 2 - Simplified block diagram of the IRU3065.

## APPLICATION INFORMATION

### Introduction

The IRU3065 is a controller intended for an inverting regulator solution. For example, to generate -5V from a 5V supply. The controller is simple and only has a voltage comparator, current hysteretic comparator, flip-flop and MOSFET driver. It controls a typical buck boost converter configured by a P-channel MOSFET, an inductor, a diode and an output capacitor. The sensed inductor current by a sensing resistor compares with current comparator. The current comparator uses hysteresis to control the turn-on and turn-off of the transistor based upon the inductor current and gated by the output voltage level. When the inductor current rises past the hysteresis set point, the output of the current comparator goes high. The flip-flop is reset and the P-channel MOSFET is turned off. In the mean time, the current sense reference is reduced to near zero, giving a zero reference threshold voltage level. As the inductor current passes below this threshold, which indicates that the inductor's stored energy has been transferred to the output capacitor, the current comparator output goes high and turns on the output transistor (if the output voltage is low). By means of hysteresis, the inductor charges and discharges and functions as self oscillating. The voltage feedback comparator acts as a demand governor to maintain the output voltage at the desired level.

By hysteresis control, the maximum switch current (also equals inductor current) is limited by the internal current sensing reference. The power limit is automatically achieved. The switching frequency is determined by a combination of factors including the inductance, output load current level and peak inductor current. The theoretical output voltage and switching frequency versus output current is shown in Figure 3.

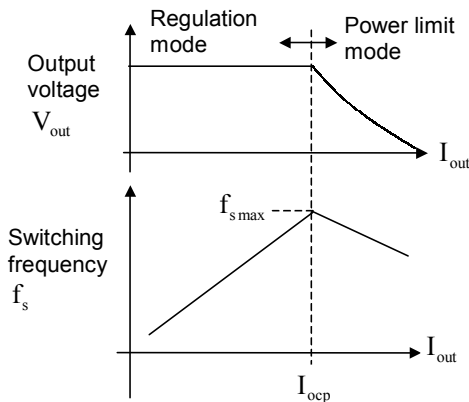

Figure 3 - Theoretical output voltage and switching frequency vs. output current.

When the output current is below a critical current  $I_{OCP}$ , the output voltage is regulated at the desired value and the switching frequency increases as output current increases. At current  $I_{OCP}$ , the switching frequency reaches its maximum  $f_{S(MAX)}$ . In this region, the operation is in regulation mode. When the current goes above  $I_{OCP}$ , the operation goes into power limit mode. The output voltage starts to decrease and the output power is limited. The switching frequency is also reduced.

Analysis shows that the current  $I_{OCP}$  is determined by:

$$I_{OCP} = \frac{1}{2} \times \frac{V_{ISEN(TH)}}{R_s} \times \frac{V_{IN}}{V_{IN} - V_{OUT(NOM)} + V_D} \quad ---(1)$$

Where:

$R_s$  = Current Sensing Resistance

$V_{ISEN(TH)}$  = Upper Threshold Voltage at the current comparator (when  $V_{CC}=5V$ ,  $V_{ISEN(TH)}=0.145V$ )

$V_{IN}$  = Input Voltage

$V_D$  = Diode Forward Voltage

$V_{OUT(NOM)}$  = Nominal Output Voltage

The maximum switching frequency is determined by:

$$f_{S(MAX)} = \frac{V_{IN} \times (V_D - V_{OUT(NOM)})}{(V_{IN} + V_D - V_{OUT(NOM)}) \times L \times I_{PEAK}}$$

$$f_{S(MAX)} = \frac{V_{IN} \times (V_D - V_{OUT(NOM)}) \times R_s}{V_{ISEN(TH)} \times (V_{IN} + V_D - V_{OUT(NOM)}) \times L} \quad ---(2)$$

Where:

$I_{PEAK}$  = Peak Inductor Current

$I_{PEAK}$  is determined by:

$$I_{PEAK} = \frac{V_{ISEN(TH)}}{R_s} \quad ---(3)$$

The detailed operation can be seen in the theoretical operation section

## APPLICATION EXAMPLE

### Design Example

The following design example is for the evaluation board application for IRU3065. The schematic is shown in figure 1:

Where:

$$V_{IN} = 5V$$

$$V_{OUT(NOM)} = -5V$$

$$I_{OUT} = 200mA$$

$f_{S(MAX)}$  = Maximum Frequency

$$f_{S(MAX)} = 1.2MHz$$

$V_D$  = Diode Forward Voltage

$$V_D = 0.5V$$

$$V_{CC} = 5V$$

$$V_{ISEN(TH)} = 145mV \cong 150mV$$

### Voltage Sensing Resistor

The output voltage is determined by the two voltage sensing resistors R2 and R3:

$$V_{OUT(NOM)} = -\frac{R3}{R2} \times V_{REF}$$

If R3 is chosen as 10K, Then R2 is given by:

$$R2 = -\frac{V_{REF}}{V_{OUT(NOM)}} \times R3 = \frac{5V}{-5V} \times 10K = 10K\Omega$$

### Current Sensing Resistor $R_s$

In order to select  $R_s$ , the desired critical current  $I_{OCP}$  has to be determined. Considering the switching losses, for conservative, the critical current should select to be slightly greater than the nominal output current.

Select:

$$I_{OCP} = 200mA \times 1.5 = 300mA$$

Where 1.5 is the coefficient to take the efficiency into account.

According to equation (1), the current  $I_{OCP}$  is given by:

$$I_{OCP} = \frac{1}{2} \times \frac{0.15}{R_s} \times \frac{V_{IN}}{V_{IN} - V_{OUT(NOM)} + V_D} = 300mA$$

The current sensing resistance is calculated as:

$$R_s = \frac{1}{2} \times \frac{0.15}{I_{OCP}} \times \frac{V_{IN}}{V_{IN} - V_{OUT(NOM)} + V_D}$$

$$R_s = \frac{1}{2} \times \frac{0.15}{0.3} \times \frac{5}{5 - (-5) + 0.5} \approx 0.12\Omega$$

Select  $R_s = 0.1\Omega$

From equation (3), the modified inductor peak current is:

$$I_{PEAK} = \frac{V_{ISEN(TH)}}{R_s} = 1.5A$$

The modified current  $I_{OCP}$  is:

$$I_{OCP} = \frac{1}{2} \times \frac{V_{IN}}{V_{IN} + V_D - V_{OUT(NOM)}} \times \frac{0.15}{R_s}$$

$$I_{OCP} = \frac{1}{2} \times \frac{5}{5 + 0.5 - (-5)} \times 1.5A = 357mA$$

### Output Inductor L

The inductance is chosen by equation (2):

$$L \geq \frac{V_{IN} \times (V_D - V_{OUT(NOM)})}{(V_{IN} + V_D - V_{OUT(NOM)}) \times f_{S(MAX)} \times I_{PEAK}}$$

$$L \geq \frac{5}{1.5A} \times \frac{V_{OUT(NOM)} \times f_{S(MAX)} \times I_{PEAK}}{(5 - (-5) + 0.5) \times 1.2MHz} = 1.45\mu H$$

Select  $L = 1.2\mu H$

The maximum inductor current is:  $I_{PEAK} = 1.5A$

The maximum average inductor current equals

$$I_{AVG} = (V_{ISENTH\_MAX} + V_{ISENTH\_MIN}) / R_s / 2$$

$$I_{AVG} = (145mV + 50mV) / 0.1ohm / 2 = 1A$$

### MOSFET Selection

A P-channel MOSFET is required. The peak current in this case is equal to  $I_{PEAK} = 1.5A$ . The MOSFET IRLML5203, from international Rectifier with  $I_D = 3A$  and  $BVDSS = 30V$ , is a good choice.

### Input Capacitor

An input capacitor will help to minimize the induced ripple on the +5V supply. A  $1\mu F$  to  $10\mu F$  X7R ceramic capacitor is recommended.

### Output Capacitor

An output capacitor is required to store energy from transfer to the output inductor. Its capacitance and ESR have a great impact on output voltage ripple. A  $10\mu F$  to  $22\mu F$  X7R Tantalum or ceramic capacitor is recommended.

### Output Diode

The average diode current equals output current. In this case, select the diode average current larger than 300mA. The lowest block voltage is  $V_{IN} + (-V_{OUT})$ . In this case, it is 10V. In order to reduce the switching losses, the Schottky diode is recommended. The diode 10BQ015 from International Rectifier with  $I_D = 1A$  and  $V_{BR} = 15V$  is a good choice.

### Other Components

In order to speed up the turn off of P-channel MOSFET, a fast diode 1N4148 or a 100ohm resistor and 100pF capacitor is connected to the pin  $V_{DD}$  and  $V_{GATE}$  as shown

in figure 1. The schottky diode can be replaced with a 100Ω resistor (Figure 28.) with a small sacrifice of efficiency but lower cost.

### Thermal Consideration

The thermal design is to ensure maximum junction temperature of IRU3065 will not exceed the maximum operation junction temperature, which is 125°C. The junction temperature can be estimated by the following:

$$T_J = P_D \times \Theta_{JA} + T_A \leq T_{J(MAX)} = 125^\circ\text{C}$$

Where  $\Theta_{JA}$  is the thermal resistance from junction to case which is usually provided in the specification.  $P_D$  is the power dissipation.  $T_A$  is the ambient temperature. The package thermal resistance of IRU3065 is estimated as 230C/W due to compact package.

Assuming the maximum allowed ambient temperature is 70C, the maximum power dissipation of IRU3065 will be

$$P_D < (125-70C)/\Theta_{JA} = (125-70)/230 = 240\text{mW}$$

### For High Power Application

The IR3065 driver is designed to driver PMOS for low current applications. Figure 4. shows the rise time versus cap load. For big capacitor load, the rise time is increasing.

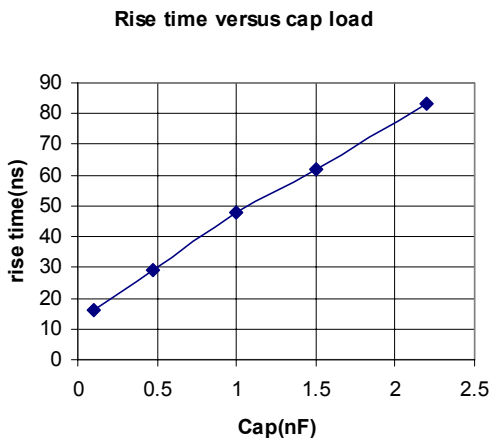

Fig.4. Rise time versus cap load.

The internal gate driver of IRU3065 is designed for load current up to 1A. For higher power applications, external driver is recommended to driver the external FETs.

### Demo board Evaluation Results

Fig.1 shows the evaluation board schematic and the selected components. The diode D1 can be replaced with a 100ohm resistor. The measured efficiency versus load current is shown in Fig. 6. With the boot strap schottky diode, the efficiency is slight higher comparing with using 100ohm resistor.

If higher efficiency is preferred, lower operation frequency should be selected. Figure. 5 shows a efficiency curve when 4.7uH inductor is chosen. The maximum operation frequency reduces from 800k to 250kHz. As a results, efficiency is more than 10% higher.

For the application circuit shown in Fig.1. The measured output voltage versus output current is shown in Figure 7. When the load current approaches 400mA, the output voltage starts to drop and goes into power limit mode. When output is about 1A, the output voltage will goes almost zero.

The measured frequency versus load is listed in Figure 8. The highest switching frequency occurs at about 440mA. As load current goes up, the IC goes into power limit mode and frequency automatically goes down to protect the system.

The current sensing comparator threshold voltage versus VCC is shown in Figure. 9. Since this threshold is only a divided voltage of VCC, it will changes when VCC changes. This should be aware in the application.

The output voltage versus  $V_{in}=VCC$  is shown in figure 11. Since the voltage reference is set by  $V_{in}$ . When  $V_{in}$  changes, the output voltage will change along  $V_{in}$ . Sometimes this feature is preferable since  $V_{out}$  may want to be tracked with  $V_{in}$  except the polarity. However, if more accurate output is required, a external voltage reference should set the output voltage.

For the evaluation board, the measured inductor voltage waveforms are listed in Figure 13-17. Figure 15 shows the measured inductor voltage waveform when output current is 250mA, which the converter is operated in regulation mode and output voltage is regulated at desired voltage -5V. Figure 16 shows the measured inductor voltage waveform when the output current is equal to the critical current  $I_{OCP}$ . Figure 17 shows the measured inductor voltage waveform when the output is in short circuit, which indicates that the converter is in power limit mode and output voltage is near zero.

**Characteristics of IRU3065**

**Efficiency versus load current**

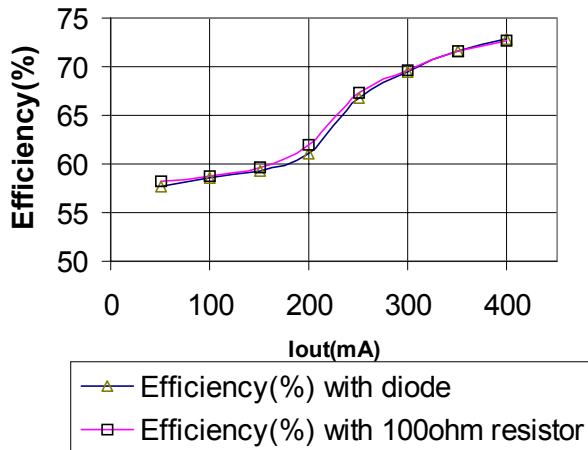

Figure.5 Efficiency with 4.7uH inductor, 250kHz operation

**Vout(V) vs Iout(mA)**

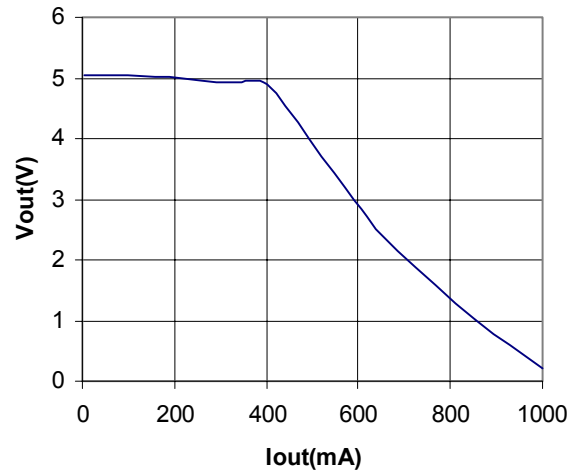

Fig.7. Output voltage (absolute value) versus load current. (Vout= -5V, Iocp=400mA)

**Efficiency versus load current**

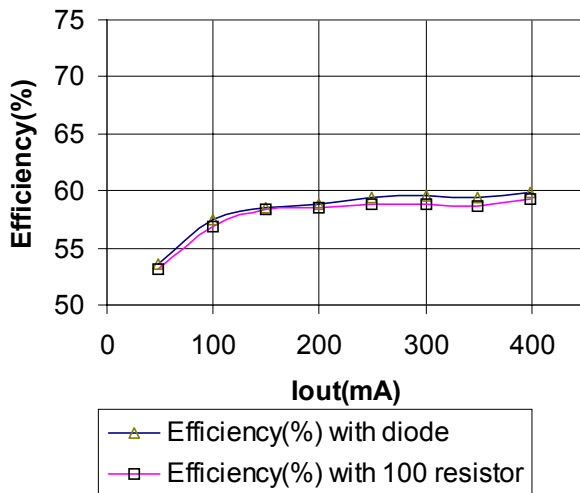

Figure 6. Efficiency with 1.2uH inductor, 800k Hz operation

**Frequency (KHz) versus load current**

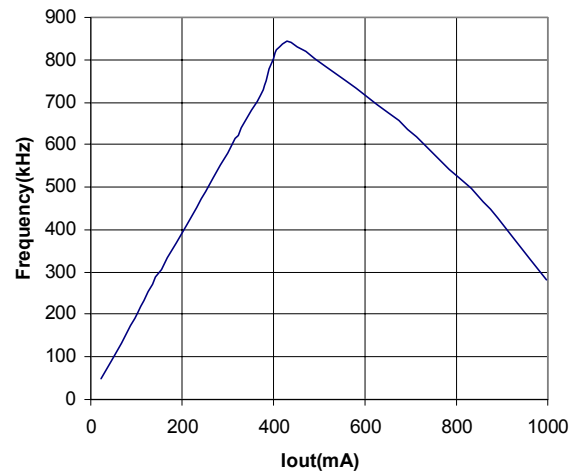

Fig.8. Frequency versus load current. (Vout= -5V, Iocp=400mA).

Characteristics of IRU3065( Continued)

Current comparator threshold versus Vin (TA=25C)

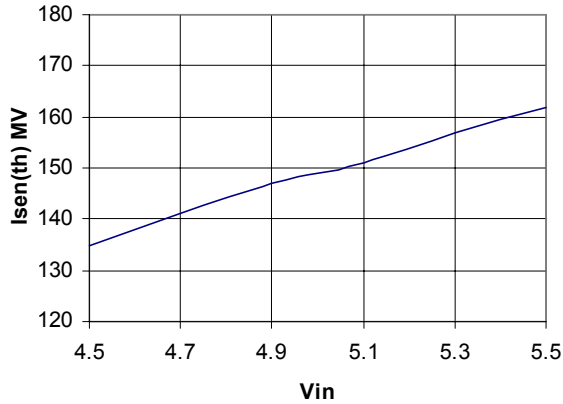

Figure 9. Current sensing comparator upper threshold versus VCC=Vin.

Output voltage versus Vin@Iout=200mA, TA=25C

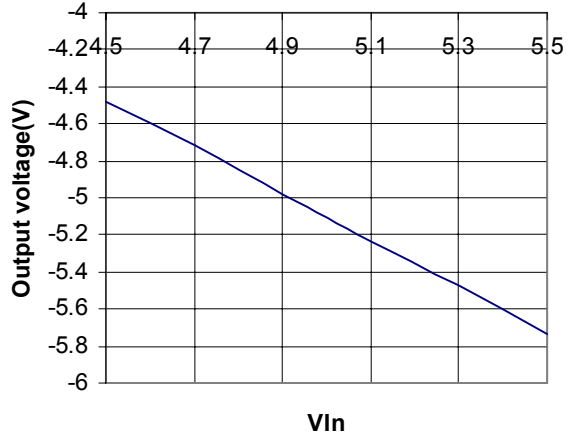

Figure. 11. Output voltage versus Vin (Vcc=Vin).

Current sensing comparator upper threshold (mV) versus temperature

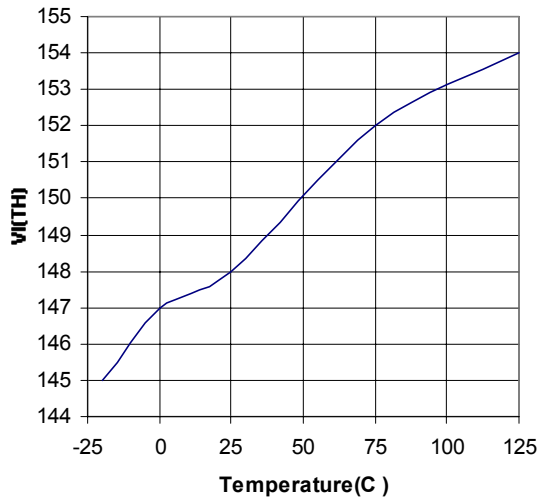

Figure. 10. Current sensing comparator upper threshold versus temperature (Vcc=5V)

Output voltage versus temperature (Vin=5V, Iout=200mA)

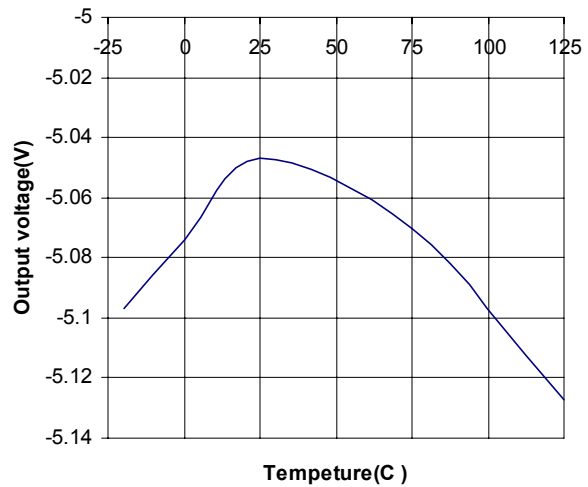

Figure. 12. Output voltage versus temperature at Vcc=Vin=5V and Iout=200mA.



Operation Waveforms of Demo board in Figure. 5

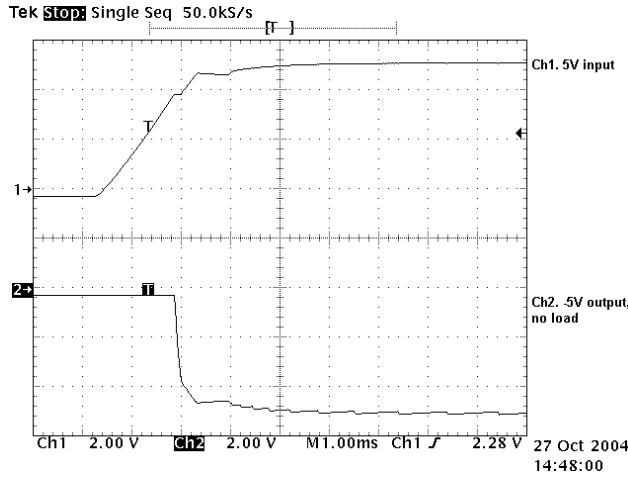

Figure. 13 Start up

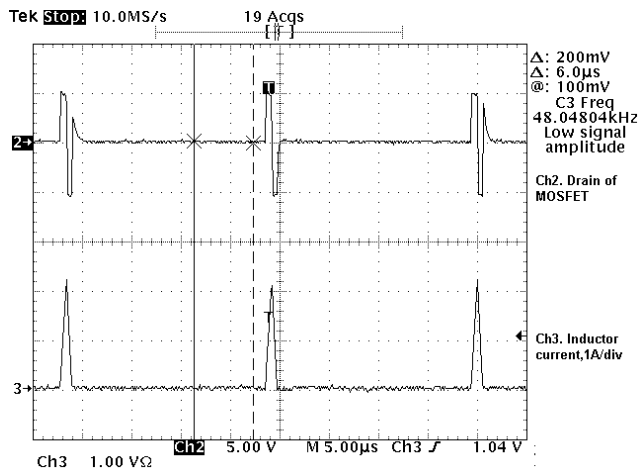

Fig. 14. Operation waveform with 20mA load.

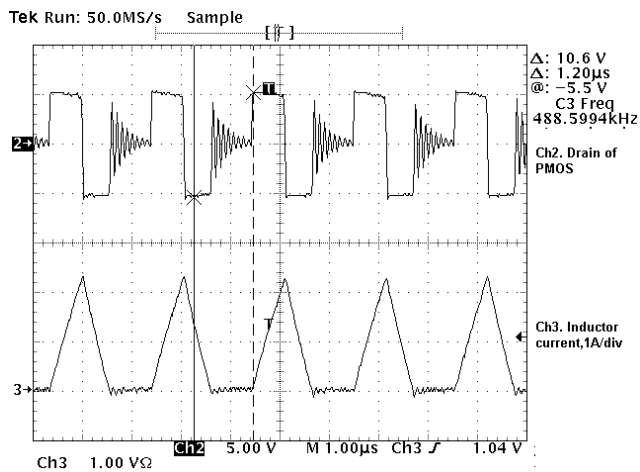

Fig. 15. Operation waveforms with 250mA load (normal operation)

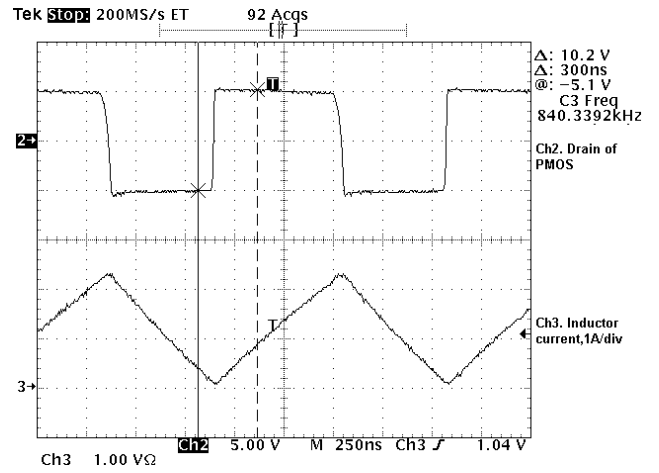

Fig. 16. Operation waveform with 450mA, the boundary of continuous mode and discontinuous mode. The output start out of regulation

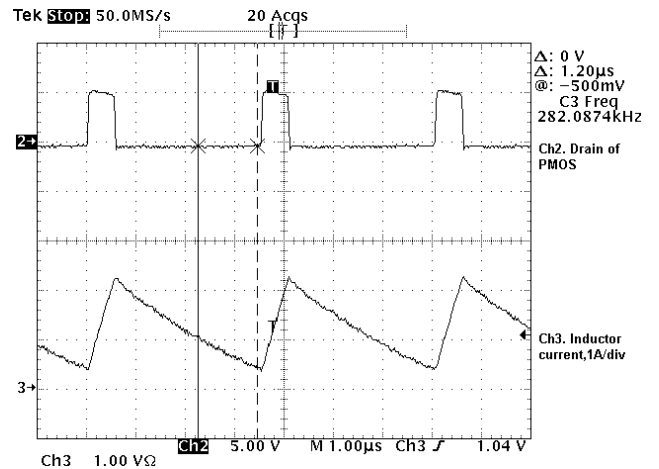

Fig. 17. operation waveform with short output.

## THEORETICAL OPERATION

### Operation-Regulation Mode

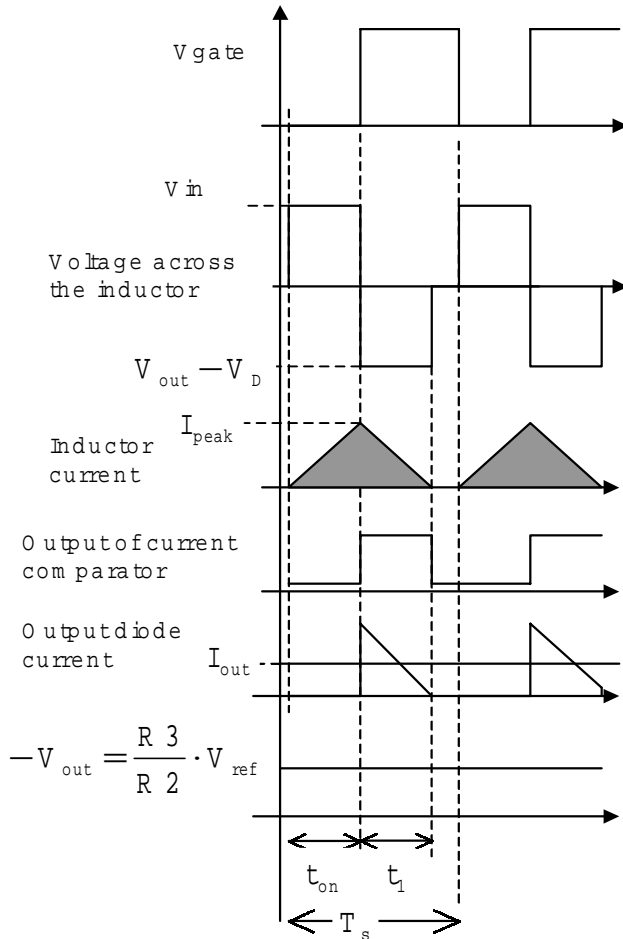

Figure 18 - Operation waveforms of IRU3065 controlled buck boost converter at regulation mode.

In general, IRU3065 controlled buck boost converter is operated in two modes depending on the load current. When the load current is small, the buck boost operated in first mode (regulation mode). The operation waveforms are shown in figure 18. In this mode, the inductor current in the buck converter is discontinuous. **Basic Operation**

When the voltage at V<sub>SEN</sub> pin is below zero, the flip-flop inside the IC is set and the V<sub>GATE</sub> pin output low, which trigger the PMOS in the power stage, the output inductor current increases from zero. When sensed inductor current voltage at I<sub>SEN</sub> pin reaches the internal current

reference of the chip, which is set to be 150mV (for V<sub>CC</sub>=5V), the flip-flop is reset and the PMOS is turned off. The inductor current is discharged through diode D2 to the load. The load voltage increases. When the inductor current decreases to zero, the output current is supplied by the output capacitor and the output voltage decreases until next cycle starts. In this mode, the voltage at V<sub>SEN</sub> pin is controlled near zero. Therefore, the output voltage is regulated at:

$$-V_{OUT} = \frac{R3}{R2} \times V_{REF}$$

In the evaluation board, the output voltage is regulated at -5V, as shown in figure 7. The steady state of the converter should be operated in this mode. One feature in this mode is that the shaded inductor current in figure 18 stays unchanged. The average output diode current equals output current. When the switching period decreases and frequency goes up, the average diode current increases to support more output current. The switching frequency increases linearly when the load current increases as shown in figure 20.

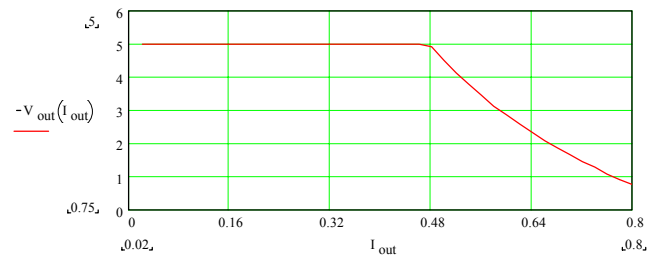

Figure 19 - Theoretical output voltage (-V<sub>OUT</sub>) versus output current for IRU3065 controlled buck boost evaluation board. (assume V<sub>SEN</sub>=0.2V)

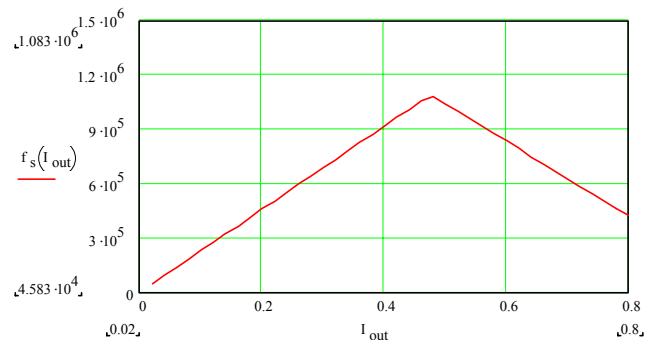

Figure 20 - Theoretical switching frequency versus output current for evaluation board. (assume V<sub>SEN</sub>=0.2V)

**Power Limit Mode**

When the output current continuous increases, the switching period continuous decreases until the inductor current goes into the boundary of discontinuous and continuous mode as shown in Figure 21. Then the IRU3065 controlled buck boost converter goes into power limit mode. In this mode, the output power is limited. The output voltage decreases when the load current increases as shown in Figure 19. In this mode, the shaded inductor current in Figure 18 keeps same. The turn off time period is dependent on the output voltage. When the output current increases, the output voltage decreases and it takes more time for the inductor current to reset from peak current to zero. Therefore, the turn off period increases. Overall the switching frequency decreases when load current increases as shown in Figure 20.

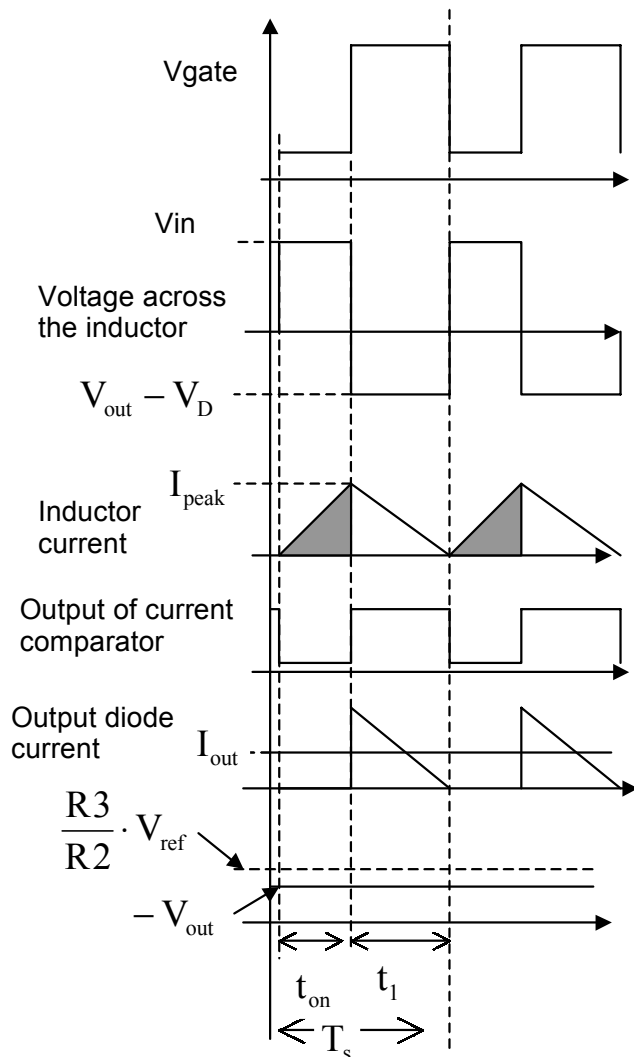

Figure 21 - Operation waveforms of IRU3065 controlled buck boost converter at power limit mode.

**Influence of System Parameters**

From above section, there is a critical output current  $I_{OCP}$ . When the output current is larger than  $I_{OCP}$ , the output voltage is out of the regulation and switching frequency starts to decrease. When output current equals  $I_{OCP}$ , the frequency reaches its maximum  $f_{S(MAX)}$ . Analysis shows that the current  $I_{OCP}$  and maximum frequency  $f_{S(MAX)}$  strongly depends on the parameters such as current sensing resistor  $R_s$  and inductance  $L$  as well as the input and output voltage.

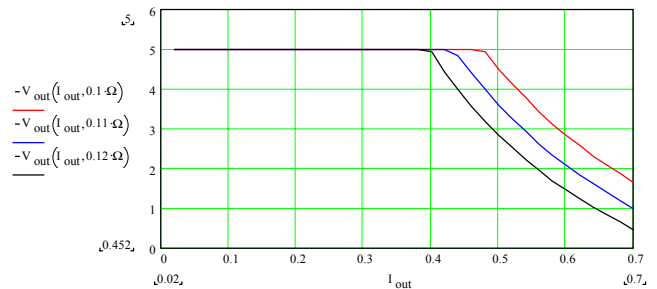

Figure 22 - Theoretical output voltage versus output current with different current sensing resistor  $R_s$ .

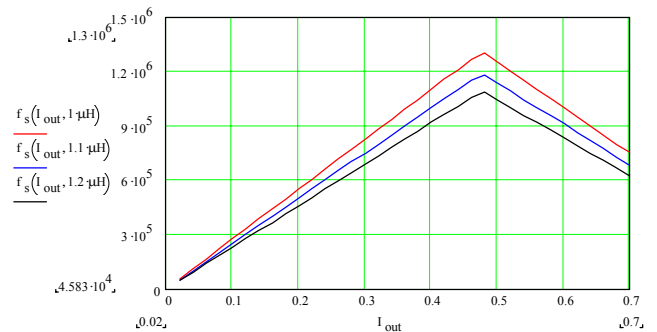

Figure 23 - Theoretical operation switching frequency versus output current with different inductance  $L$ .

Figure 22 shows the calculated output voltage versus output current with different current sensing resistor  $R_s$ . With different  $R_s$ , the critical current  $I_{OCP}$  varies, and the power process ability changes. Figure 23 shows the calculated operation switching frequency versus output current with different inductance  $L$  when  $R_s=0.1\Omega$ . The inductance  $L$  determines the maximum switching frequency of the buck boost converter.

## Analysis of Operation

### Regulation Mode

From Figure 18, when the PMOS is on, the inductor current increases from zero. That is:

$$I_L = \frac{V_{IN}}{L} \times t \quad \text{---(4)}$$

And the peak current is given by:

$$I_{PEAK} = \frac{V_{IN}}{L} \times t_{ON} \quad \text{---(5)}$$

Where  $t_{ON}$  is the turn on time of the PMOS.

Because the switch is turned off when sensed inductor current reaches threshold  $V_{ISEN}$ , the following equation holds:

$$R_S \times I_{PEAK} = R_S \times \frac{V_{IN}}{L} \times t_{ON} = V_{ISEN} = 150mV \quad \text{---(6)}$$

$$I_{PEAK} = \frac{V_{ISEN(TH)}}{R_S}$$

The turn on time of the PMOS can be calculated as:

$$t_{ON} = \frac{L \times I_{PEAK}}{V_{IN}} = \frac{V_{ISEN} \times L}{R_S \times V_{IN}} \quad \text{---(7)}$$

For inductor, by applying voltage and second balance approach, we have:

$$V_{IN} \times t_{ON} + (V_{OUT} - V_D) \times t_1 = 0$$

It can be derived as:

$$t_1 = \frac{V_{IN} \times t_{ON}}{-(V_{OUT} - V_D)} = \frac{V_{ISEN} \times L}{-(V_{OUT} - V_D) \times R_S} \quad \text{---(8)}$$

Where  $V_D$  is the forward voltage drop of output diode D2.

From Figure 18, the average current of output diode should equals the output current, resulting in:

$$I_{D(AVG)} = \frac{1}{2} \times I_{PEAK} \times \frac{t_1}{T_S} = I_{OUT} \quad \text{---(9)}$$

Where  $T_S$  is the switching period and  $f_s = \frac{1}{T_S}$

Combination of equation (6)(8)(9) results in the relationship between output current and switching frequency:

$$f_s = \frac{-R_S^2 \times (V_{OUT} - V_D)}{V_{ISEN} \times V_{ISEN} \times L} \times I_{OUT} \times 2 \quad \text{---(10)}$$

Because at regulation mode, the output voltage is regulated, i.e.  $V_{OUT} = V_{OUT(NOM)}$ . Then the equation (10) can be rewritten as:

$$f_s = \frac{-R_S^2 \times (V_{OUT(NOM)} - V_D)}{V_{ISEN} \times V_{ISEN} \times L} \times I_{OUT} \times 2 \quad \text{---(11)}$$

The expected switching frequency linearly increases as output current goes up, as shown in Figure 20.

### Power Limit Mode

When output current continuously increases and  $I_{OUT} = I_{OCP}$ , the converter is in the boundary of regulation mode and power limit mode with output voltage is regulated to nominal voltage  $V_{OUT} = V_{OUT(NOM)}$ . As current continues to increase ( $I_{OUT} > I_{OCP}$ ), the converter goes into power limit mode. In this mode, the maximum inductor current is limited by the internal current reference  $V_{ISEN} = 145mV$ . Therefore, the turn on time of the  $P_{MOS}$  keeps same as equation (7).

For turn off time, the inductor current theoretically should decrease from  $I_{PEAK}$  to zero if the threshold voltage is close to zero, therefore:

$$t_1 = \frac{L \times I_{PEAK}}{-(V_{OUT} - V_D)} = \frac{V_{ISEN} \times L}{-(V_{OUT} - V_D) \times R_S} \quad \text{---(12)}$$

Where  $V_D$  is the forward voltage drop of output diode D2.

The switching period is given by:

$$T_S = t_{ON} + t_1 = \frac{L \times I_{PEAK}}{V_{IN}} + \frac{L \times I_{PEAK}}{-(V_{OUT} - V_D)}$$

$$T_S = L \times I_{PEAK} \times \frac{V_{IN} - V_{OUT} + V_D}{-V_{IN} \times (V_{OUT} - V_D)} \quad \text{---(13)}$$

The combination of equations (12) and (13) result in the following:

$$\frac{t_1}{T_S} = \frac{V_{IN}}{V_{IN} - V_{OUT} + V_D} \quad \text{---(14)}$$

The output current equals the average diode current, which is:

$$I_{OUT} = \frac{1}{2} \times I_{PEAK} \times \frac{t_1}{T_S}$$

$$I_{OUT} = \frac{1}{2} \times \frac{V_{ISEN}}{R_S} \times \frac{V_{IN}}{V_{IN} - V_{OUT} + V_D} \quad \text{---(15)}$$

Where the peak current is given by equation (6).

Equation (15) can be rewritten as:

$$V_{OUT} = V_{IN} + V_D - \frac{V_{ISEN} \times V_{IN}}{2R_S \times I_{OUT}} \quad \text{---(16)}$$

The above equation shows that the output voltage at the power limit mode is not regulated. It decreases as the output current increases.

When  $I_{OUT}=I_{OCP}$ , the output voltage equals nominal voltage  $V_{OUT}=V_{OUT(NOM)}$ . From equation (15), we have

$$I_{OCP} = \frac{1}{2} \times \frac{V_{ISEN}}{R_s} \times \frac{V_{IN}}{V_{IN} - V_{OUT} + V_D} \quad \text{---(17)}$$

The above equation is used to select the current sensing resistor  $R_s$ .

Substitution of equation (16) into equation (13) results in the relationship between frequency and output current, that is

$$f_s = \frac{V_{IN}}{L \times I_{PEAK}} \times \left( 1 - \frac{2 \times I_{OUT}}{I_{PEAK}} \right) \text{---(18)}$$

The above equation indicates that the switching frequency decreases when output current increases during power limit mode.

When  $I_{OUT}=I_{OCP}$ , the switching frequency reaches its maximum. Substitution of  $V_{OUT}=V_{OUT(NOM)}$  and equation (6) into equation (13) results in the maximum switching frequency:

$$f_{s(MAX)} = \frac{V_{IN} \times (V_D - V_{OUT(NOM)})}{(V_{IN} + V_D - V_{OUT(NOM)}) \times L \times I_{PEAK}}$$

$$f_{s(MAX)} = \frac{V_{IN} \times (V_D - V_{OUT(NOM)}) \times R_s}{V_{ISEN} \times (V_{IN} + V_D - V_{OUT(NOM)}) \times L} \quad \text{---(19)}$$

Therefore, the inductance can be selected according to the maximum desired frequency as shown in the following:

$$L \geq \frac{V_{IN} \times (V_D - V_{OUT(NOM)})}{(V_{IN} + V_D - V_{OUT(NOM)}) \times f_{s(MAX)} \times I_{PEAK}} \quad \text{---(20)}$$

Fig. 24 and Fig.25 shows the theoretical predication and calculation results for the output voltage and frequency versus output current.

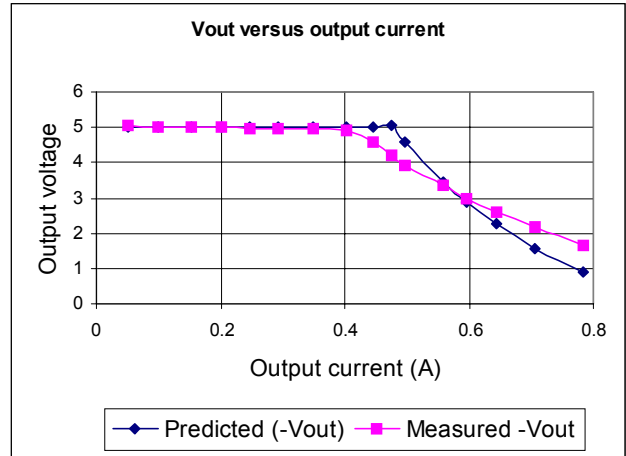

Figure 24- The comparison between predicted and measured output voltage versus output current

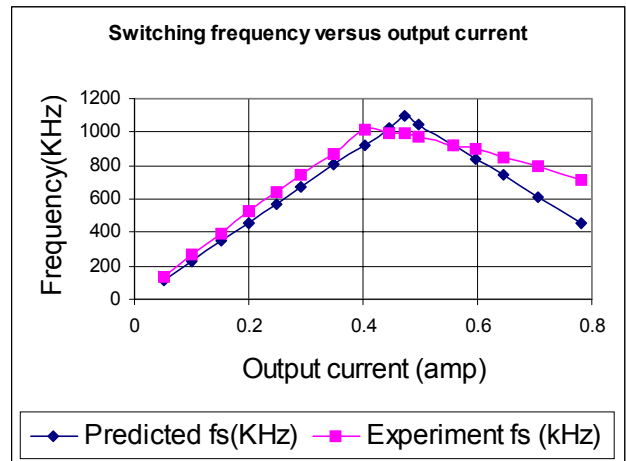

Figure 25 - The comparison between predicted and measured switching frequency versus output current

Other Applications

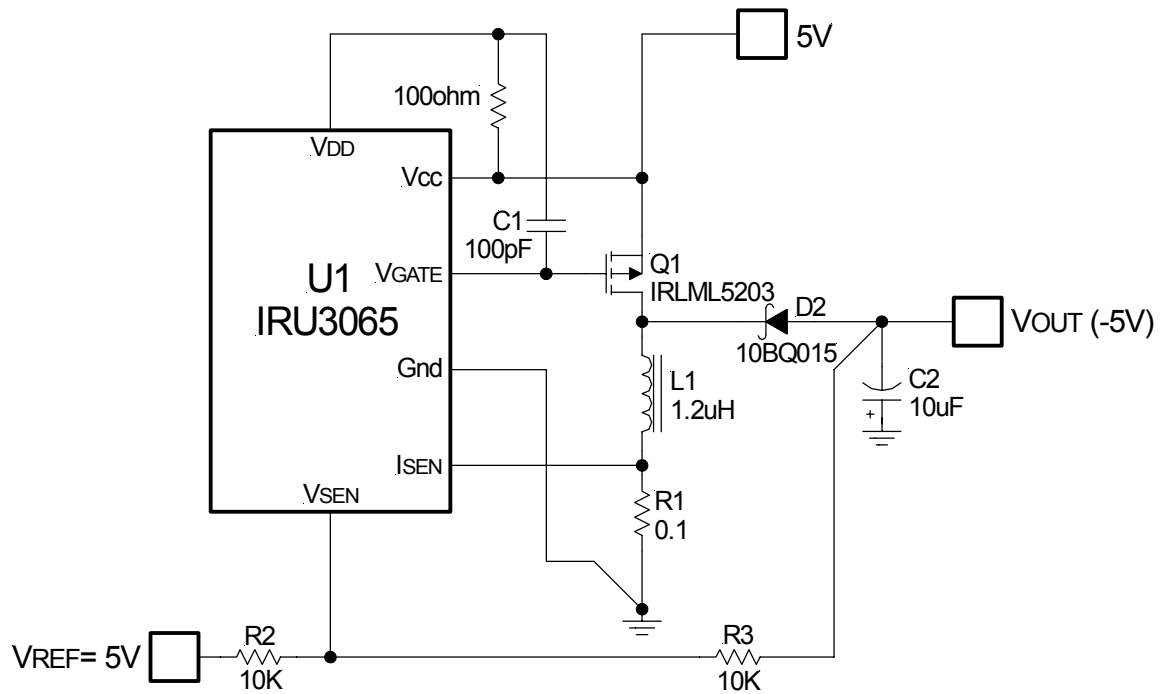
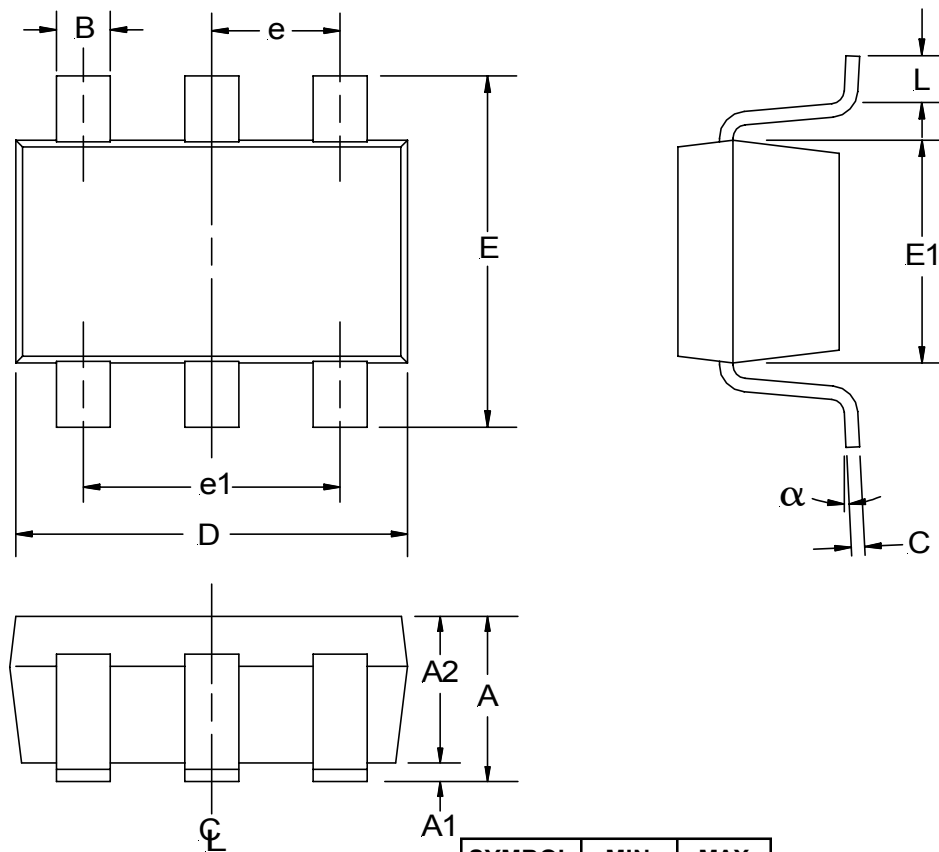

Fig. 26 . IRU3065 application with 100ohm resistor and 100pf cap

**(L6) SOT-23 Package**



SYMBOL	MIN	MAX
A	0.90	1.45
A1	0.00	0.15
A2	0.90	1.30
B	0.35	0.50
C	0.09	0.20
D	2.80	3.00
E	2.60	3.00
E1	1.50	1.75
e	0.95 REF	
e1	1.90 REF	
L	0.10	0.60
$\alpha$	0°	10°

NOTE: ALL MEASUREMENTS  
 ARE IN MILLIMETERS.