

PHS Transceiver GaAs MMIC

GENERAL DESCRIPTION

NJG1717KT2 is a GaAs multi-function MMIC composed of a power amplifier, a SPDT switch and a LNA+MIXER for Japanese PHS or WLL application.

NJG1717KT2 is operated at low voltage, and includes a low current and low distortion PA, a low insertion loss antenna switch and a low noise and high gain LNA+MIXER.

The small QFN24-T2 package is applied.

PACKAGE OUTLINE

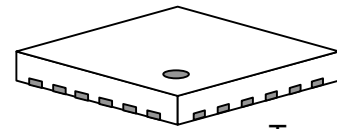

Top view

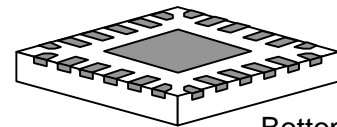

Bottom view

NJG1717KT2

FEATURES

| | | |
|------------------------------------|---|------------|
| ●Supply Voltage | PA | 3.0V |
| | SW, LNA, MIXER | 2.7V |
| ●Low current consumption | Tx mode | 150mA typ. |
| | Rx mode | 8.3mA typ. |
| ●Ultra small & ultra thin package | QFN24-T2 (Package Size: 4.0 x 4.0 x 0.78mm) | |
| ○TX Mode (PA+ANT SW) | | |
| ●High Gain | 39dB typ. @Pout=+20.2dBm | |
| ●Adjacent Channel leak Power Ratio | -63dBc typ. @offset 600kHz | |
| ○RX Mode (ANT SW+LNA+MIXER) | | |
| ●High Conversion Gain | 20.5dB typ. @ f _{RF} =1900MHz, f _{LO} =1660MHz, P _{LO} =-15dBm | |
| ●Low noise figure | 2.6dB typ. @ f _{RF} =1900MHz, f _{LO} =1660MHz, P _{LO} =-15dBm | |
| ●High input IP3 | -10dBm typ. @ f _{RF} =1900.0+1900.6MHz, f _{LO} =1660MHz | |
| ●Image suppression ratio | 36dB typ. @ f _{RF} =1900/1420MHz | |

PIN CONFIGURATION

(Top View)

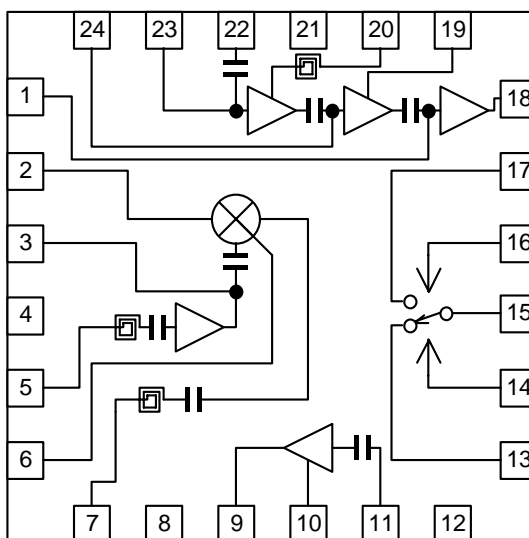

Pin Connection

| | |
|------------|-----------|
| 1. VBB3 | 13. P2 |
| 2. IFOUT | 14. VCTL2 |
| 3. VLO | 15. PC |
| 4. NC(GND) | 16. VCTL1 |
| 5. LOIN | 17. P1 |
| 6. BPC | 18. PAOUT |
| 7. MIXIN | 19. VCC2 |
| 8. GND1 | 20. VCC1 |
| 9. LNAOUT | 21. GND3 |
| 10. LNACAP | 22. PAIN |
| 11. LNAIN | 23. VBB1 |
| 12. GND2 | 24. VBB2 |

●Exposed PAD: GND

NOTE: Please note that any information on this catalog will be subject to change.

NJG1717KT2

■ ABSOLUTE MAXIMUM RATINGS

(T_a=+25°C)

| PARAMETER | SYMBOL | CONDITIONS | RATINGS | UNITS |
|--------------------------------------|----------------------|---|----------|-------|
| Supply Voltage | V _{CC} | I _{idle} =140mA | 6.0 | V |
| V _{CC} Terminal Current | I _{CC} | | 330 | mA |
| Control Voltage1, 2 | V _{CTL1, 2} | | 7.5 | V |
| LNA Voltage | V _{LNA} | | 5.0 | V |
| MIXER Voltage | V _{MIX} | | 5.0 | V |
| Local Amplifier Voltage | V _{LO} | | 5.0 | V |
| Input Power 1 (PA IN terminal) | P _{PAIN} | V _{CC} =3.0V, I _{idle} =140mA | +3.0 | dBm |
| Input Power 2 (ANT terminal) | P _{ANTIN} | V _{LNA} =V _{MIX} =V _{LO} =2.7V | -5.0 | dBm |
| Input Power 3 (LOCAL IN terminal) | P _{LOIN} | V _{LNA} =V _{MIX} =V _{LO} =2.7V | +10.0 | dBm |
| Power Dissipation | P _D | At on PCB(FR4), T _j =150°C | 620 | mW |
| Operating Temperature | T _{opr} | | -40~+85 | °C |
| Storage Temperature | T _{stg} | | -55~+150 | °C |

■ ELECTRICAL CHARACTERISTICS 1 (DC)

GENERAL CONDITIONS: T_a=+25°C, V_{CC}=3.0V, V_{CTL(L)}=0V, V_{CTL(H)}=2.7V, V_{LNA}=V_{MIX}=V_{LO}=2.7V

| PARAMETER | SYMBOL | CONDITIONS | MIN | TYP | MAX | UNITS |
|--------------------------------------|---------------------|--|------|-----|------|-------|
| Supply Voltage | V _{CC} | | 2.7 | 3.0 | 5.0 | V |
| Base Voltage | V _{BB} | I _{CC} =150mA | 1.2 | 1.6 | 2.0 | V |
| Idle Current | I _{idle} | PA IN: No signal | - | 140 | 200 | mA |
| Base Current | I _{BB} | PA IN: No signal | - | 1.0 | 1.4 | mA |
| Operating Voltage (Low) | V _{CTL(L)} | | -0.2 | 0 | 0.2 | V |
| Operating Voltage (High) | V _{CTL(H)} | | 2.5 | 2.7 | 6.5 | V |
| Control Current | I _{CTL} | PA IN, RF, LO: No signal | - | 8.0 | 14.0 | uA |
| LNA Voltage | V _{LNA} | | 2.5 | 2.7 | 4.5 | V |
| LNA Operating Current | I _{LNA} | P _{RF} , P _{LO} =OFF | - | 2.8 | 3.5 | mA |
| MIXER Operating Voltage | V _{MIX} | | 2.5 | 2.7 | 4.5 | V |
| MIXER Current | I _{MIX} | P _{RF} , P _{LO} =OFF | - | 4.6 | 5.7 | mA |
| Local Amplifier Voltage | V _{LO} | | 2.5 | 2.7 | 4.5 | V |
| Local Amplifier Operating Current | I _{LO} | P _{RF} , P _{LO} =OFF | - | 0.9 | 1.3 | mA |

■ ELECTRICAL CHARACTERISTICS 2 (TX: PA+ANT SW)

GENERAL CONDITIONS: $T_a=+25^{\circ}\text{C}$, $V_{CC}=3.0\text{V}$, $V_{CTL1}=2.7\text{V}$, $V_{CTL2}=0\text{V}$, $I_{CC}=150\text{mA}$,
 $f_{RF}=1900\text{MHz}$, $P_{OUT}=+20.2\text{dBm}$, $Z_s=Z_L=50\Omega$

| PARAMETER | SYMBOL | CONDITIONS | MIN | TYP | MAX | UNITS |
|------------------------------------|----------------------|--|------|------|------|-------|
| Operating Frequency | freq | | 1880 | 1900 | 1920 | MHz |
| V_{CC} Terminal Current | I_{CC} | | - | 150 | - | mA |
| Power Gain | Gp | | 36 | 39 | - | dB |
| Gain Flatness | Gflat _{TX} | $f_{RF}=1880\sim 1920\text{MHz}$ | - | 0.5 | 1.0 | dB |
| Pout at 1dB Gain Compression Point | $P_{-1\text{dB TX}}$ | | +19 | +21 | - | dBm |
| Adjacent Channel leak Power Ratio1 | ACPR1 | Pin: $\pi/4\text{QPSK}$, Burst off, offset 600kHz | - | -63 | -55 | dBc |
| Adjacent Channel leak Power Ratio2 | ACPR2 | Pin: $\pi/4\text{QPSK}$, Burst off, offset 900kHz | - | -70 | -60 | dBc |
| 2nd Harmonics 3rd Harmonics | Phm | | - | -35 | -30 | dBc |
| Occupied bandwidth | OBW | | - | 250 | 275 | kHz |
| PA IN VSWR | VSWR1 | Small signal PA IN terminal | - | 1.5 | 2.0 | |
| ANT VSWR (Transmit active) | VSWR2 | Small signal ANT terminal | - | 1.5 | 2.0 | |

■ TRUTH TABLE

Control Voltage: "High"= $V_{CTL(H)}$, "Low"= $V_{CTL(L)}$

| Pass | VCTL1 | VCTL2 |
|----------------|-------|-------|
| PC(ANT)-P1(TX) | High | Low |
| PC(ANT)-P2(RX) | Low | High |

NJG1717KT2

■ ELECTRICAL CHARACTERISTICS 3 (RX: ANT SW+LNA+MIXER)

GENERAL CONDITIONS: $T_a=+25^{\circ}\text{C}$, $V_{\text{CTL1}}=0\text{V}$, $V_{\text{CTL2}}=V_{\text{LNA}}=V_{\text{MIX}}=V_{\text{LO}}=2.7\text{V}$, $f_{\text{RF}}=1900\text{MHz}$,
 $f_{\text{LO}}=1660\text{MHz}$, $P_{\text{RF}}=-45\text{dBm}$, $P_{\text{LO}}=-15\text{dBm}$, $Z_s=Z_l=50\Omega$

| PARAMETER | SYMBOL | CONDITIONS | MIN | TYP | MAX | UNITS |
|-----------------------------------|----------------------|---|-------|-------|------|-------|
| Operating Frequency | freq | | 1880 | 1900 | 1920 | MHz |
| LNA Operating Current | ILNA | | - | 2.8 | 3.5 | mA |
| MIXER Operating Current | IMIX | | - | 4.6 | 5.7 | mA |
| LNA Operating Current | ILO | | - | 0.9 | 1.3 | mA |
| Conversion Gain | Gc | | 16.5 | 20.5 | - | dB |
| Gain Flatness | Gflat _{RX} | $f_{\text{RF}}=1880\sim 1920\text{MHz}$ | - | 0.5 | 1.5 | dB |
| Noise Figure | NF | SSB | - | 2.6 | 3.5 | dB |
| Input 3rd order Intercept Point | IIP3 | $f_{\text{RF}}=1900.0+1900.6\text{MHz}$ | -14 | -10 | - | dBm |
| Pin at 1dB Gain Compression Point | P _{-1dB RX} | | -25.5 | -21.5 | - | dBm |
| Image suppression ratio | IMR | $f_{\text{RF}}=1900/1420\text{MHz}$ | 31 | 36 | - | dB |
| 1/2 IF suppression ratio | 1/2IFR | $f_{\text{RF}}=1900/1780\text{MHz}$ | 49 | 55 | - | dB |
| 2×LO-IF suppression ratio | SPR1 | $f_{\text{RF}}=1900/3080\text{MHz}$ | 39 | 47 | - | dB |
| 2×LO+IF suppression ratio | SPR2 | $f_{\text{RF}}=1900/3560\text{MHz}$ | 24 | 62 | - | dB |
| LO to ANT leak | PIk | | - | -55 | -45 | dBm |
| ANT VSWR (Receive active) | VSWR3 | | - | 1.5 | 2.0 | |
| LOCAL IN VSWR | VSWR4 | | - | 2.0 | 2.5 | |
| IF OUT VSWR | VSWR5 | | - | 1.5 | 2.0 | |

■ TERMINAL INFORMATION

| No. | SYMBOL | DESCRIPTION |
|-----|---------|---|
| 1 | VBB3 | This terminal is for base bias supply of the 3rd stage of power amplifier. Operation current of the power amplifier is adjusted by changing the bias voltage applied to this terminal. Please connect bypass capacitors C12 and C13 with ground plane close to this terminal. Please connect pin 23 and pin 24, and connect the resistor R1 for temperature characteristic compensation of PA gain. |
| 2 | IFOUT | IF signal output terminal. The IF signal is output through external matching circuit connected to this terminal. Please connect inductances L6, L7 and power supply as shown in the application circuit, since this terminal is also the terminal of mixer power supply. |
| 3 | VLO | Power supply terminal for local amplifier. Please place L5 and C8 shown in the application circuit, very close to this terminal. |
| 4 | NC(GND) | Nonconnection terminal. Please connect with Ground terminal. |
| 5 | LOIN | Local signal input terminal connected to the local amplifier. An external matching circuit is required. |
| 6 | BPC | Terminal to connect to the external bypass capacitor of mixer. The bypass capacitor C7 shown in the application circuit should be connected to this terminal as close as possible. |
| 7 | MIXIN | Input terminal of RF signal to the mixer. An external matching circuit is required. |
| 8 | GND1 | Ground terminal (0V) |
| 9 | LNAOUT | Output terminal of LNA. The RF signal from LNA goes out through external matching circuit connected to this terminal. Please connect inductances L3, L4 and power supply as shown in the application circuit, since this terminal is also the terminal of LNA power supply. |
| 10 | LNACAP | Terminal to connect to an external bypass capacitor of LNA. The bypass capacitor C4 shown in the application circuit should be connected to this terminal as close as possible. |
| 11 | LNAIN | RF input terminal of LNA. An external matching circuit is required. |
| 12 | GND2 | Ground terminal (0V) |
| 13 | P2 | RF port. This terminal is one of ports of SPDT SW. This terminal connects to PC terminal (pin 15) when logical high voltage signal is supplied to VCTL2 (pin 14) and logical low voltage signal is supplied to VCTL1 (pin 16). External capacitor C3 is required to block the DC bias voltage of internal circuit. |

NJG1717KT2

| No. | SYMBOL | DESCRIPTION |
|-----|--------|--|
| 14 | VCTL2 | Control port. Please connect bypass capacitor C2 with ground plane close to this terminal. |
| 15 | PC | Common RF port. The terminal PC is connected to the terminal P1 or the terminal P2 by the voltage supplied to the terminal VCTL1 and VCTL2. In order to block the DC bias voltage of internal circuit, external capacitor C1 is required. |
| 16 | VCTL1 | Control port. Please connect bypass capacitor C24 with ground plane close to this terminal. |
| 17 | P1 | RF port. This terminal is one of ports of SPDT SW. This terminal connects to PC terminal (pin 15) when logical low voltage signal is supplied to VCTL2 (pin 14) and logical high voltage signal is supplied to VCTL1 (pin 16). External capacitor C23 is required to block the DC bias voltage of internal circuit. |
| 18 | PAOUT | Output terminal of power amplifier. The RF signal from power amplifier goes out through an external matching circuit connected to this terminal. Moreover, this terminal should be connected to DC power supply through inductor L9 shown in the application circuit, since it is the terminal for power supply of the 3rd stage of Power Amplifier. |
| 19 | VCC2 | This terminal is for DC power supply of the 2nd stage of power amplifier. Please place bypass capacitors C17 and C18 between this terminal and GND as near as possible. |
| 20 | VCC1 | This terminal is for DC power supply of the 1st stage of power amplifier. Please place bypass capacitors C15 and C16 between this terminal and GND as near as possible. |
| 21 | GND3 | Ground terminal (0V) |
| 22 | PAIN | RF input terminal of power amplifier. An external matching circuit is required. |
| 23 | VBB1 | This terminal is for base bias supply of the 1st stage of power amplifier. Operation current of the power amplifier is adjusted by changing the bias voltage applied to this terminal. Please connect bypass capacitors C12 and C13 with ground plane close to this terminal. Please connect pin 24 and pin 1, and connect the resistor R1 for temperature characteristic compensation of PA gain. |
| 24 | VBB2 | This terminal is for base bias supply of the 2nd stage of Power Amplifier. Operation current of the power amplifier is adjusted by changing the bias voltage applied to this terminal. Please connect bypass capacitors C12 and C13 with ground plane close to this terminal. Please connect pin 23 and pin 1, and connect the resistor R1 for temperature characteristic compensation of PA gain. |

■ TYPICAL CHARACTERISTICS (TX: PA + ANT SW SECTION)

Output Power, Gp vs. Input Power

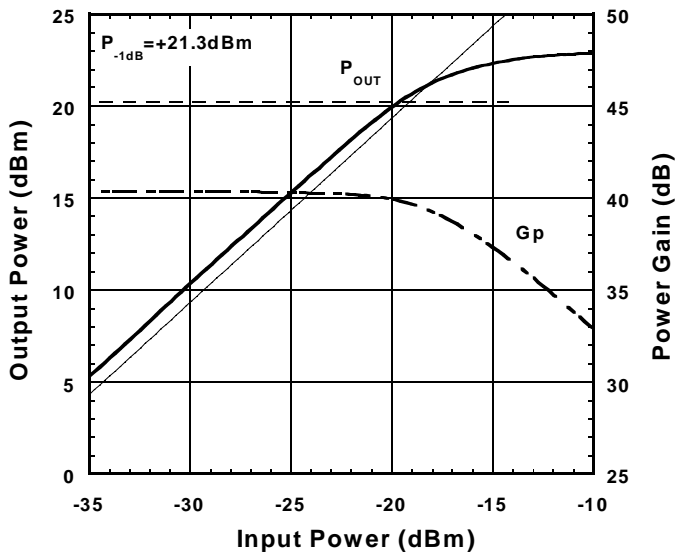

Condition
 $f_{RF}=1900\text{MHz(CW)}$, $T_a=+25^\circ\text{C}$
 $V_{BB}=\text{Const. (@}I_{CC}=150\text{mA)}$
 $V_{CC}=3.0\text{V}$, $V_{CTL1}=2.7\text{V}$
 $V_{CTL2}=V_{LNA}=V_{MIX}=V_{LO}=0\text{V}$

Output Power, ACPR vs. Input Power

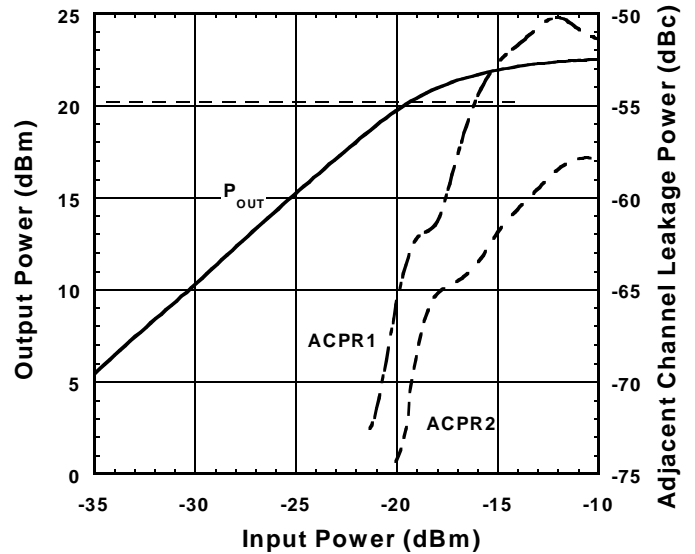

Condition
 $f_{RF}=1900\text{MHz}(\pi/4\text{DQPSK})$, $T_a=+25^\circ\text{C}$
 $V_{BB}=\text{Const. (@}I_{CC}=150\text{mA)}$
 $V_{CC}=3.0\text{V}$, $V_{CTL1}=2.7\text{V}$
 $V_{CTL2}=V_{LNA}=V_{MIX}=V_{LO}=0\text{V}$

Output Power, ICC vs. Input Power

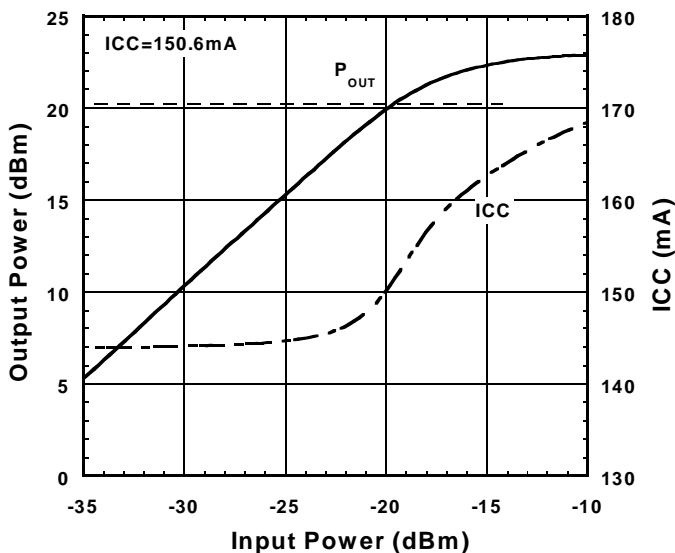

Condition
 $f_{RF}=1900\text{MHz(CW)}$, $T_a=+25^\circ\text{C}$
 $V_{BB}=\text{Const. (@}I_{CC}=150\text{mA)}$
 $V_{CC}=3.0\text{V}$, $V_{CTL1}=2.7\text{V}$
 $V_{CTL2}=V_{LNA}=V_{MIX}=V_{LO}=0\text{V}$

Output Power, PAE vs. Input Power

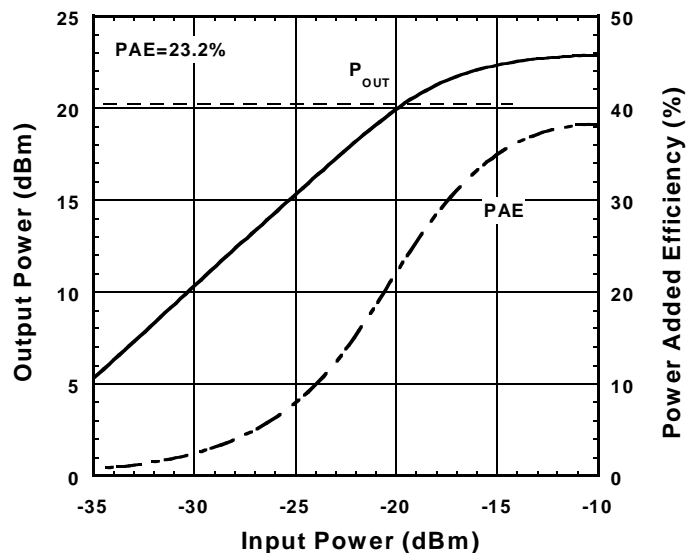

Condition
 $f_{RF}=1900\text{MHz(CW)}$, $T_a=+25^\circ\text{C}$
 $V_{BB}=\text{Const. (@}I_{CC}=150\text{mA)}$
 $V_{CC}=3.0\text{V}$, $V_{CTL1}=2.7\text{V}$
 $V_{CTL2}=V_{LNA}=V_{MIX}=V_{LO}=0\text{V}$

NJG1717KT2

TYPICAL CHARACTERISTICS (TX: PA + ANT SW SECTION)

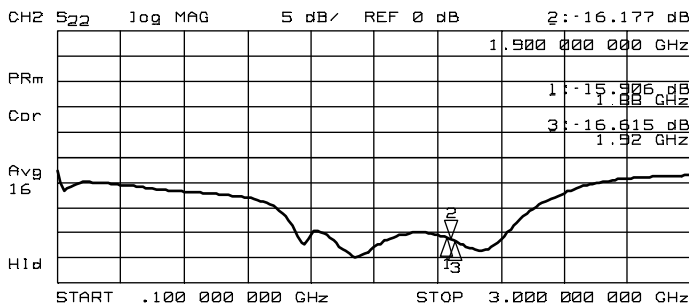
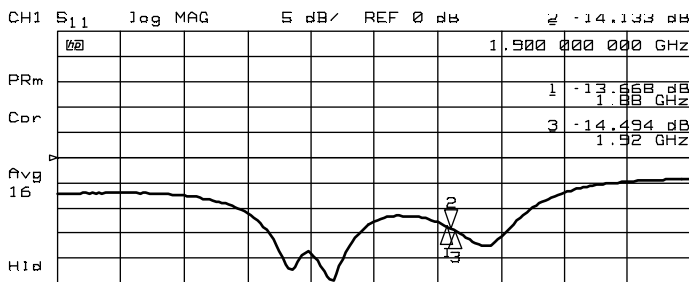

Condition
 Ta=+25°C
 V_{BB}=Const. (@I_{CC}=150mA)
 V_{CC}=3.0V, V_{CTL1}=2.7V
 V_{CTL2}=V_{LNA}=V_{MIX}=V_{LO}=0V

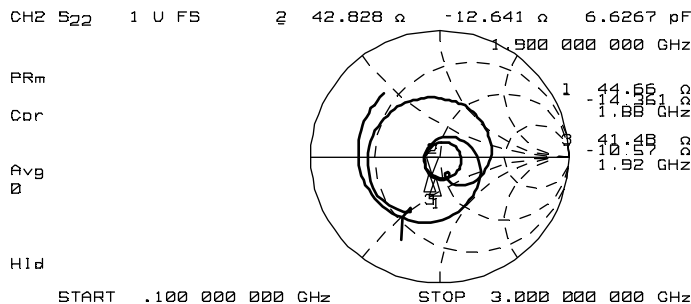
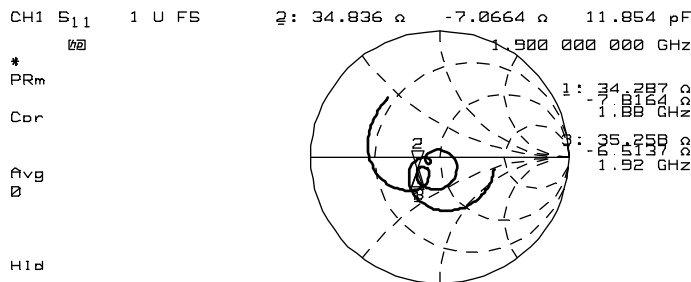

Condition
 Ta=+25°C
 V_{BB}=Const. (@I_{CC}=150mA)
 V_{CC}=3.0V, V_{CTL1}=2.7V
 V_{CTL2}=V_{LNA}=V_{MIX}=V_{LO}=0V

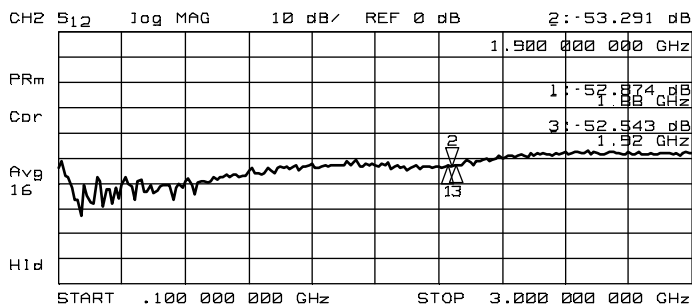
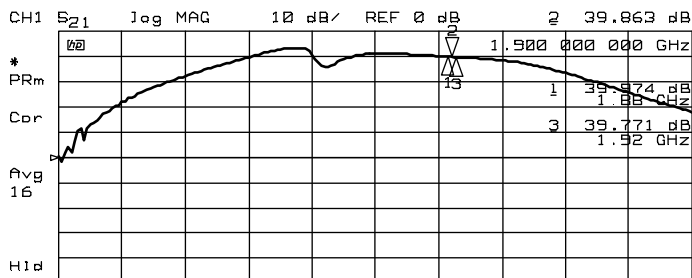

Condition
 Ta=+25°C
 V_{BB}=Const. (@I_{CC}=150mA)
 V_{CC}=3.0V, V_{CTL1}=2.7V
 V_{CTL2}=V_{LNA}=V_{MIX}=V_{LO}=0V

■ TYPICAL CHARACTERISTICS (TX: PA + ANT SW SECTION)

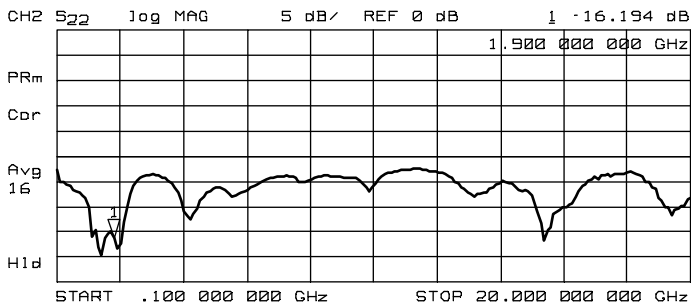
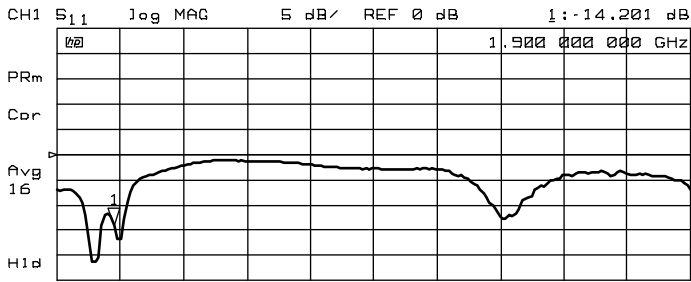

Condition
 Ta=+25°C
 V_{BB}=Const. (@I_{CC}=150mA)
 V_{CC}=3.0V, V_{CTL1}=2.7V
 V_{CTL2}=V_{LNA}=V_{MIX}=V_{LO}=0V

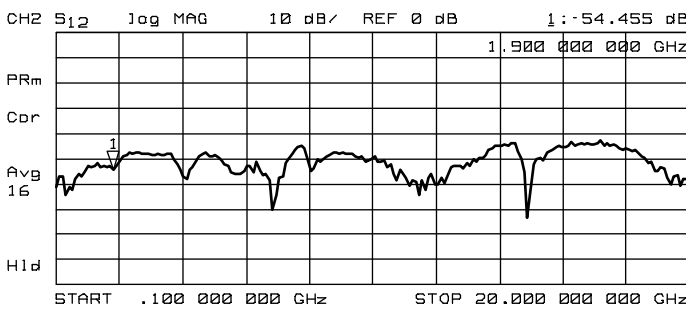
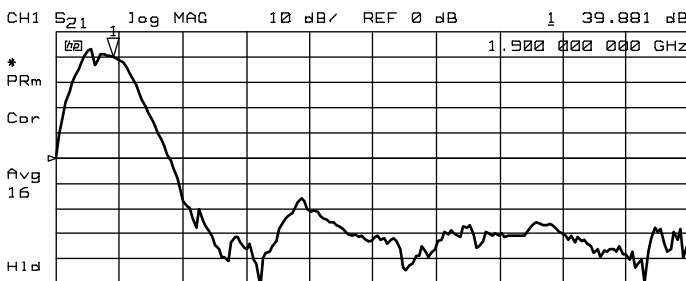

Condition
 Ta=+25°C
 V_{BB}=Const. (@I_{CC}=150mA)
 V_{CC}=3.0V, V_{CTL1}=2.7V
 V_{CTL2}=V_{LNA}=V_{MIX}=V_{LO}=0V

NJG1717KT2

■ TYPICAL CHARACTERISTICS (TX: PA + ANT SW SECTION)

Gp, P_{-1dB} vs. VBB Terminal Voltage

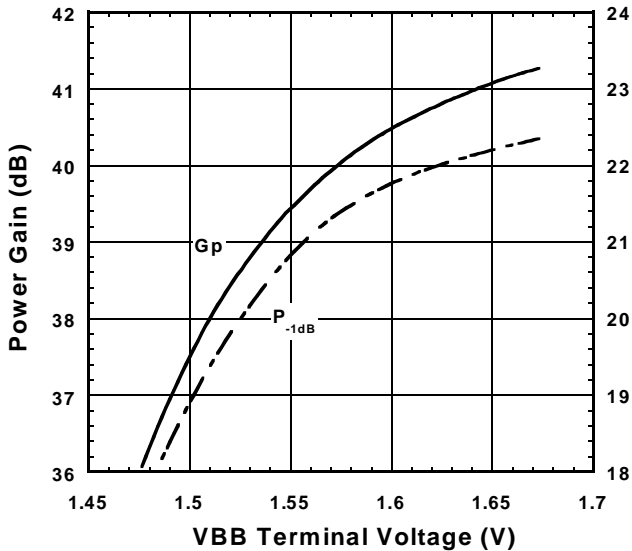

Condition
 $f_{RF}=1900\text{MHz(CW)}$
 $P_{OUT}=+20.2\text{dBm}$, $T_a=+25^\circ\text{C}$
 $V_{CC}=3.0\text{V}$, $V_{CTL1}=2.7\text{V}$
 $V_{CTL2}=V_{LNA}=V_{MIX}=V_{LO}=0\text{V}$

ACPR1, ACPR2 vs. VBB Terminal Voltage

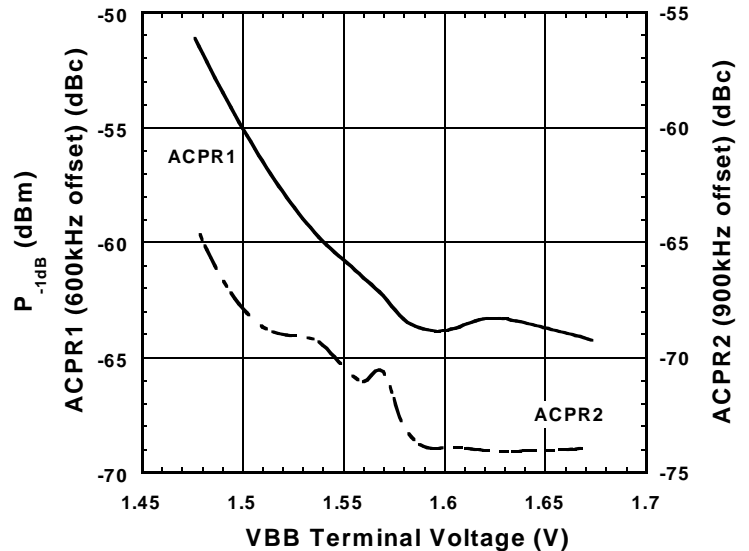

Condition
 $f_{RF}=1900\text{MHz}(\pi/4\text{DQPSK})$
 $P_{OUT}=+20.2\text{dBm}$, $T_a=+25^\circ\text{C}$
 $V_{CC}=3.0\text{V}$, $V_{CTL1}=2.7\text{V}$
 $V_{CTL2}=V_{LNA}=V_{MIX}=V_{LO}=0\text{V}$

Iidle, Ibb vs. VBB Terminal Voltage

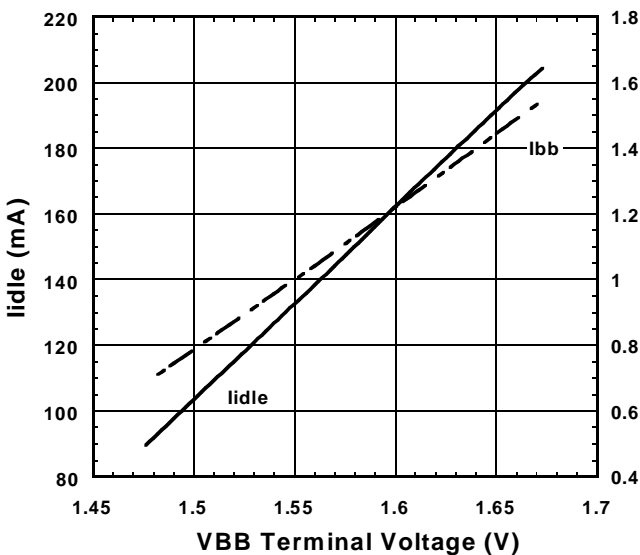

Condition
 $T_a=+25^\circ\text{C}$
 $V_{CC}=3.0\text{V}$, $V_{CTL1}=2.7\text{V}$
 $V_{CTL2}=V_{LNA}=V_{MIX}=V_{LO}=0\text{V}$

ICC, IBB vs. VBB Terminal Voltage

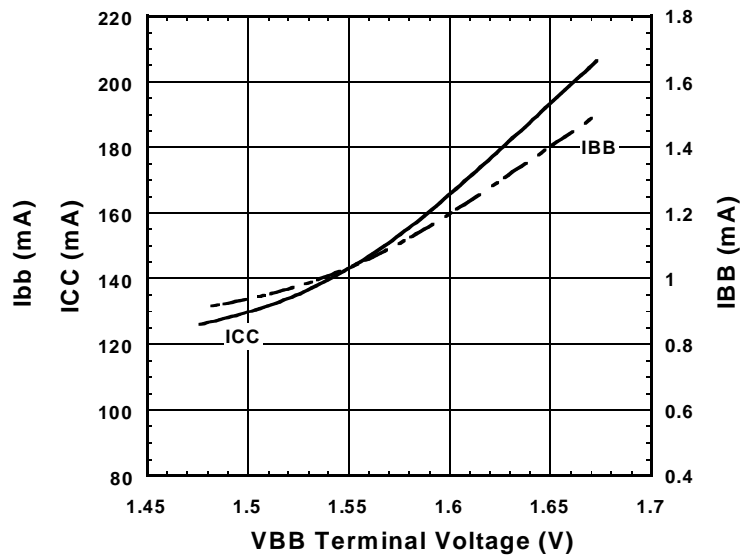

Condition
 $f_{RF}=1900\text{MHz(CW)}$
 $P_{OUT}=+20.2\text{dBm}$, $T_a=+25^\circ\text{C}$
 $V_{CC}=3.0\text{V}$, $V_{CTL1}=2.7\text{V}$
 $V_{CTL2}=V_{LNA}=V_{MIX}=V_{LO}=0\text{V}$

■ TYPICAL CHARACTERISTICS (TX: PA + ANT SW SECTION)

Phm vs. VBB Terminal Voltage

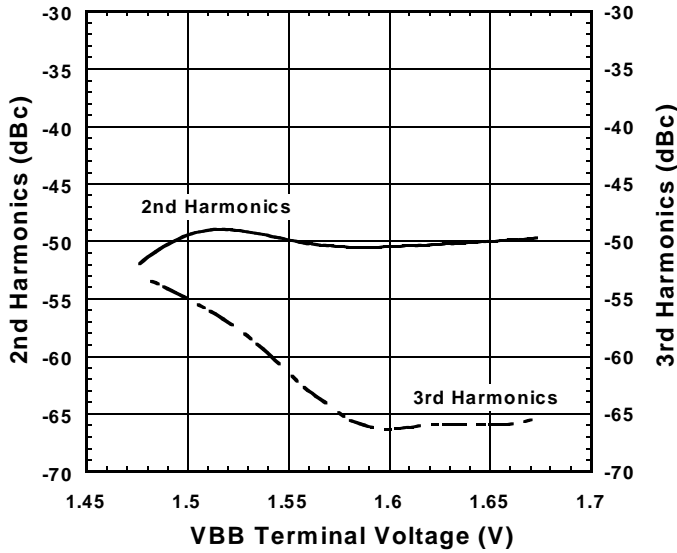

OBW vs. VBB Terminal Voltage

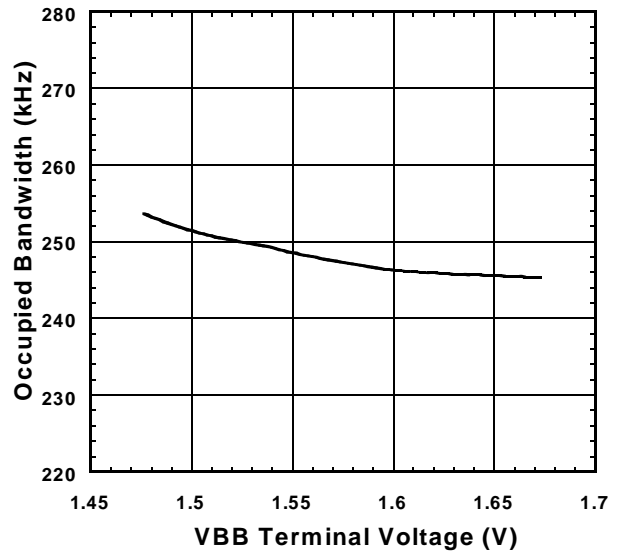

Gp, P_{-1dB} vs. VCC Terminal Voltage

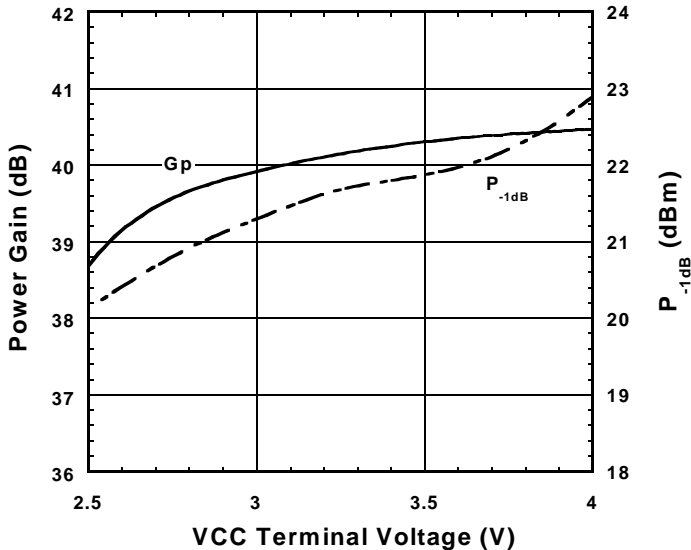

ACPR1, ACPR2 vs. VCC Terminal Voltage

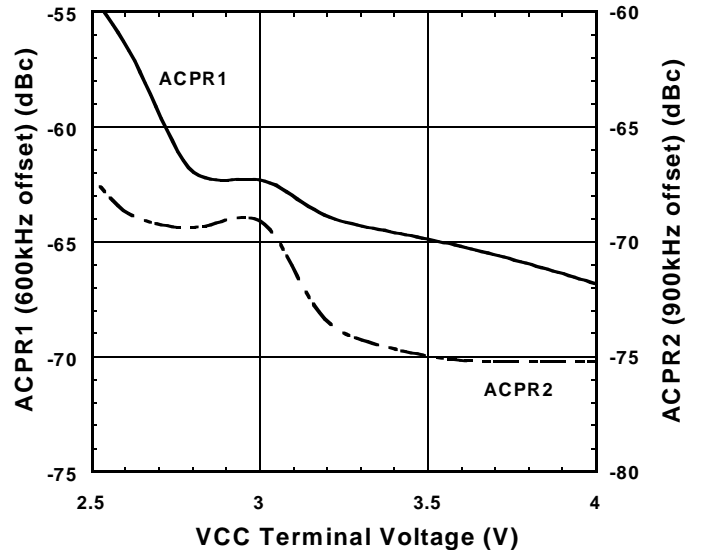

NJG1717KT2

■ TYPICAL CHARACTERISTICS (TX: PA + ANT SW SECTION)

Idle, I_{bb} vs. V_{CC} Terminal Voltage

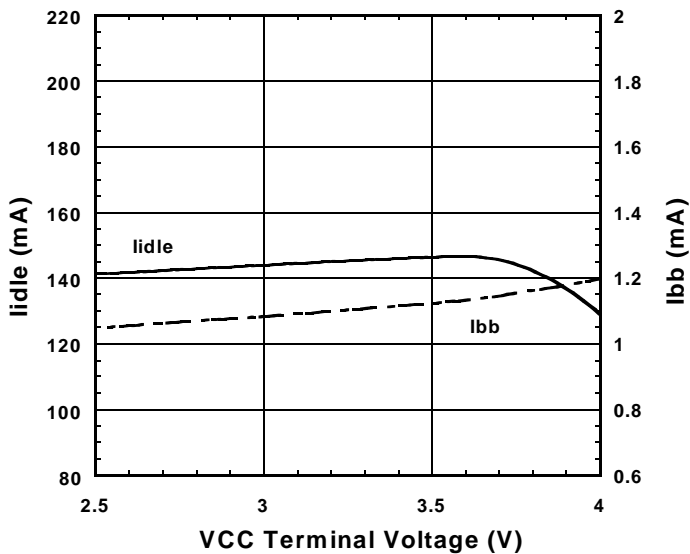

Condition
 T_a=+25°C
 V_{BB}=Const. (@I_{CC}=150mA, V_{CC}=3.0V)
 V_{CTL1} =2.7V, V_{CTL2}=V_{LNA}=V_{MIX}=V_{LO}=0V

ICC, I_{BB} vs. V_{CC} Terminal Voltage

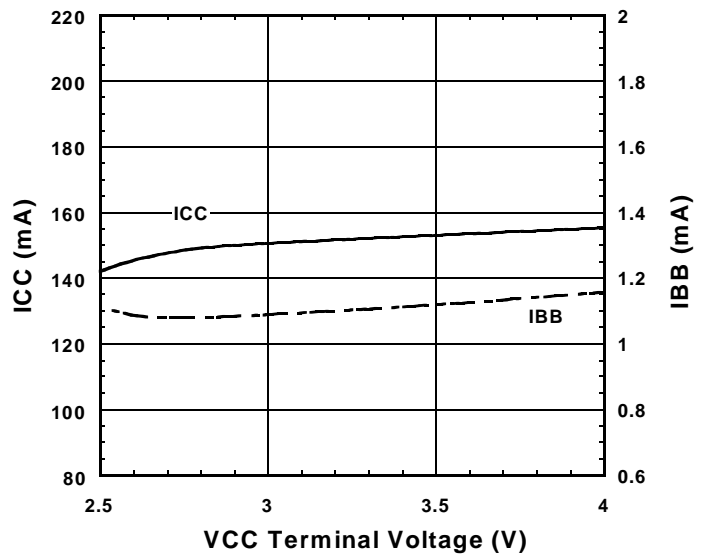

Condition
 f_{RF}=1900MHz(CW)
 P_{OUT}=+20.2dBm, T_a=+25°C
 V_{BB}=Const. (@I_{CC}=150mA, V_{CC}=3.0V)
 V_{CTL1} =2.7V, V_{CTL2}=V_{LNA}=V_{MIX}=V_{LO}=0V

Phm vs. V_{CC} Terminal Voltage

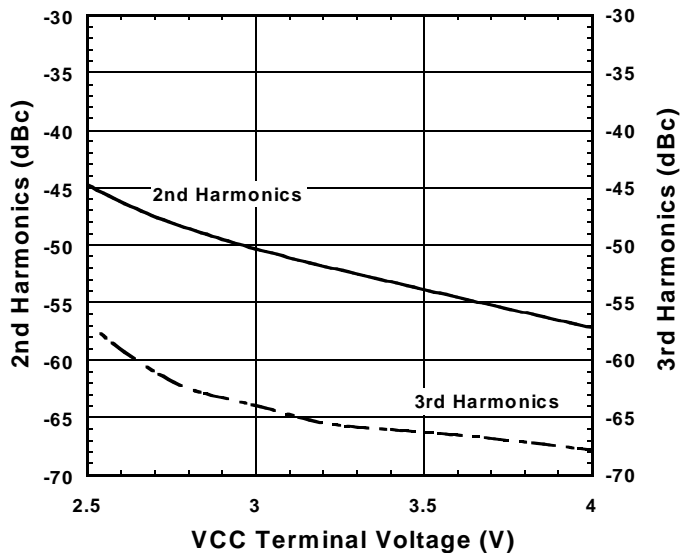

Condition
 f_{RF}=1900MHz(CW)
 P_{OUT}=+20.2dBm, T_a=+25°C
 V_{BB}=Const. (@I_{CC}=150mA, V_{CC}=3.0V)
 V_{CTL1} =2.7V, V_{CTL2}=V_{LNA}=V_{MIX}=V_{LO}=0V

OBW vs. V_{CC} Terminal Voltage

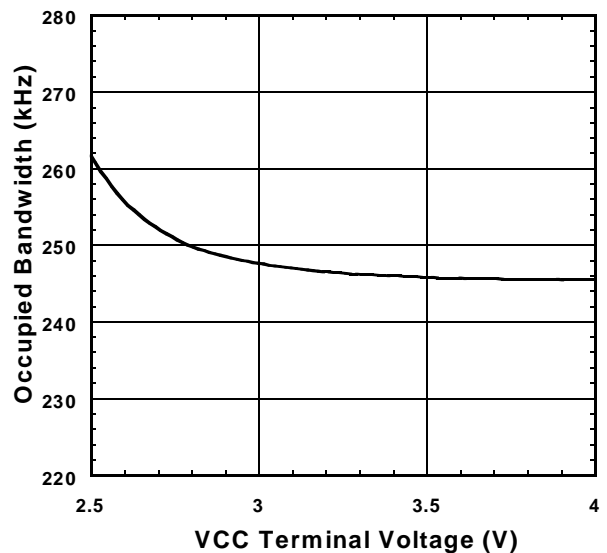

Condition
 f_{RF}=1900MHz(π/4DQPSK)
 P_{OUT}=+20.2dBm, T_a=+25°C
 V_{BB}=Const. (@I_{CC}=150mA, V_{CC}=3.0V)
 V_{CTL1} =2.7V, V_{CTL2}=V_{LNA}=V_{MIX}=V_{LO}=0V

■ TYPICAL CHARACTERISTICS (TX: PA + ANT SW SECTION)

Gp, P_{-1dB} vs. Temperature

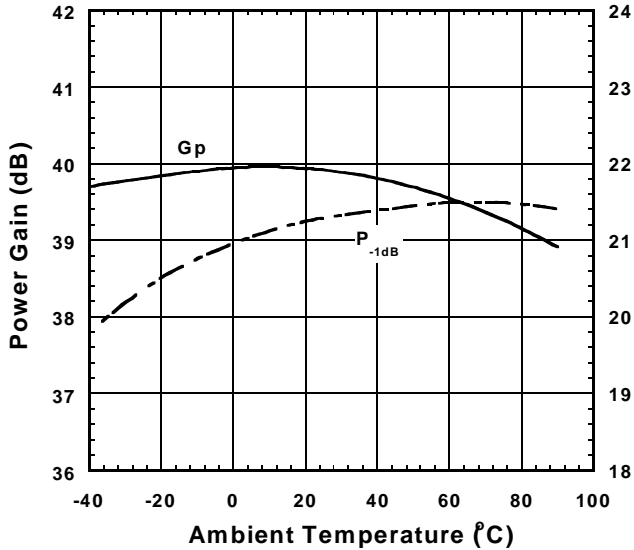

Condition
 $f_{RF}=1900\text{MHz(CW)}$
 $P_{OUT}=+20.2\text{dBm}$
 $V_{BB}=\text{Const.} (@I_{CC}=150\text{mA}, T_a=+25^\circ\text{C})$
 $V_{CC}=3.0\text{V}, V_{CTL1}=2.7\text{V},$
 $V_{CTL2}=V_{LNA}=V_{MIX}=V_{LO}=0\text{V}$

ACPR1, ACPR2 vs. Temperature

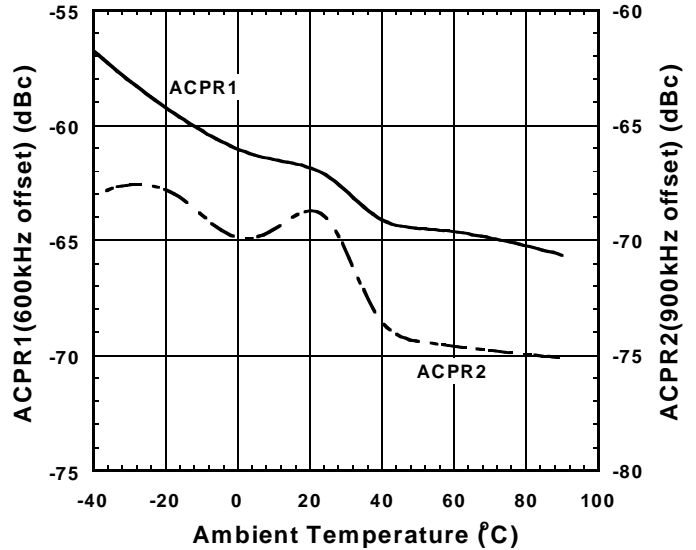

Condition
 $f_{RF}=1900\text{MHz}(\pi/4\text{DQPSK})$
 $P_{OUT}=+20.2\text{dBm}$
 $V_{BB}=\text{Const.} (@I_{CC}=150\text{mA}, T_a=+25^\circ\text{C})$
 $V_{CC}=3.0\text{V}, V_{CTL1}=2.7\text{V},$
 $V_{CTL2}=V_{LNA}=V_{MIX}=V_{LO}=0\text{V}$

I_{idle}, I_{bb} vs. Temperature

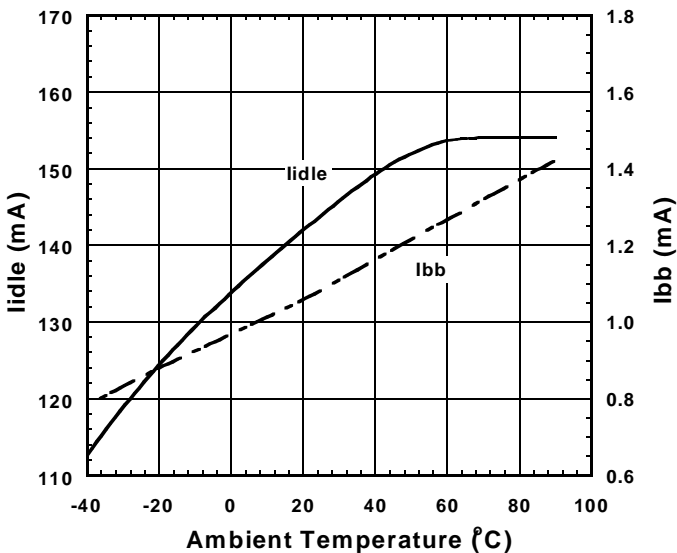

Condition
 $V_{BB}=\text{Const.} (@I_{CC}=150\text{mA}, T_a=+25^\circ\text{C})$
 $V_{CC}=3.0\text{V}, V_{CTL1}=2.7\text{V},$
 $V_{CTL2}=V_{LNA}=V_{MIX}=V_{LO}=0\text{V}$

I_{CC}, I_{BB} vs. Temperature

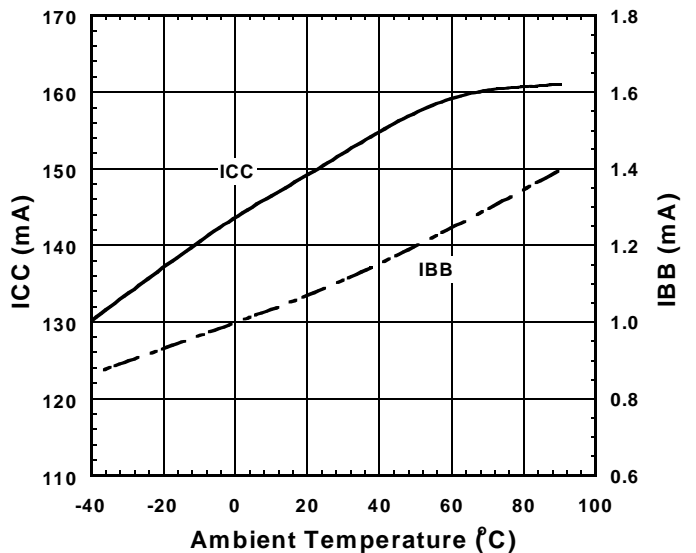

Condition
 $f_{RF}=1900\text{MHz(CW)}$
 $P_{OUT}=+20.2\text{dBm}$
 $V_{BB}=\text{Const.} (@I_{CC}=150\text{mA}, T_a=+25^\circ\text{C})$
 $V_{CC}=3.0\text{V}, V_{CTL1}=2.7\text{V},$
 $V_{CTL2}=V_{LNA}=V_{MIX}=V_{LO}=0\text{V}$

NJG1717KT2

■ TYPICAL CHARACTERISTICS (TX: PA + ANT SW SECTION)

Phm vs. Temperature

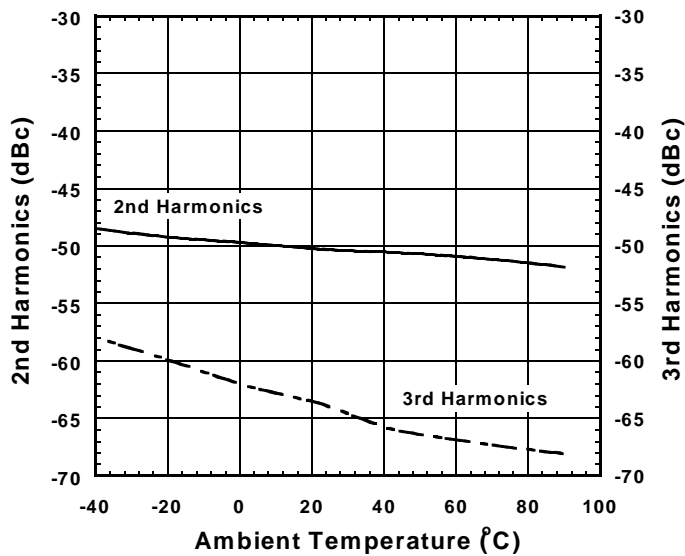

Condition
 $f_{RF}=1900\text{MHz(CW)}$
 $P_{OUT}=+20.2\text{dBm}$
 $V_{BB}=\text{Const.} (@I_{CC}=150\text{mA}, T_a=+25^\circ\text{C})$
 $V_{CC}=3.0\text{V}, V_{CTL1}=2.7\text{V},$
 $V_{CTL2}=V_{LNA}=V_{MIX}=V_{LO}=0\text{V}$

OBW vs. Temperature

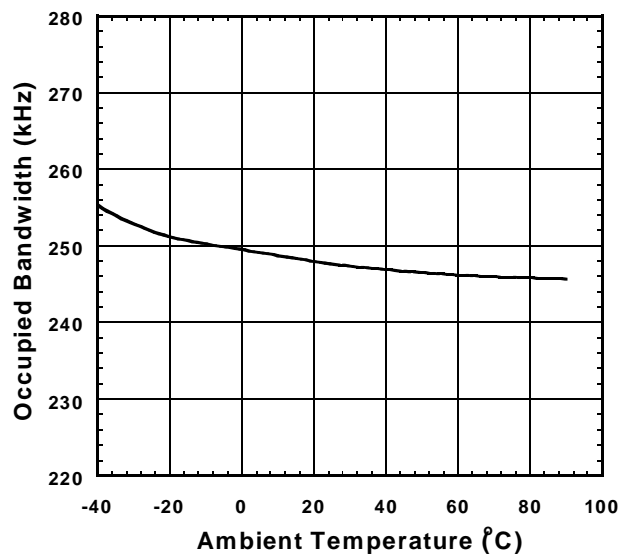

Condition
 $f_{RF}=1900\text{MHz}(\pi/4\text{DQPSK})$
 $P_{OUT}=+20.2\text{dBm}$
 $V_{BB}=\text{Const.} (@I_{CC}=150\text{mA}, T_a=+25^\circ\text{C})$
 $V_{CC}=3.0\text{V}, V_{CTL1}=2.7\text{V},$
 $V_{CTL2}=V_{LNA}=V_{MIX}=V_{LO}=0\text{V}$

PA IN to ANT K factor vs. Frequency Temperature Responce

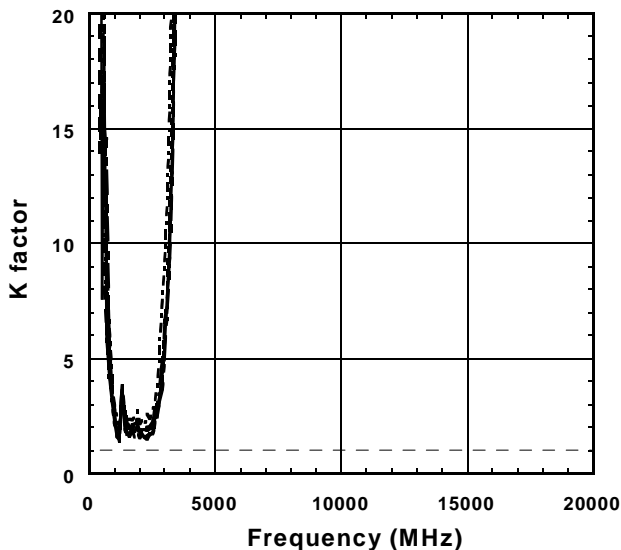

Condition
 $f_{RF}=1900\text{MHz(CW)}$
 $T_a=-40\sim+90^\circ\text{C}$
 $V_{BB}=\text{Const.} (@I_{CC}=150\text{mA}, T_a=+25^\circ\text{C})$
 $V_{CC}=3.0\text{V}, V_{CTL1}=2.7\text{V},$
 $V_{CTL2}=V_{LNA}=V_{MIX}=V_{LO}=0\text{V}$

■ TYPICAL CHARACTERISTICS (RX: ANT SW + LNA + MIXER SECTION)

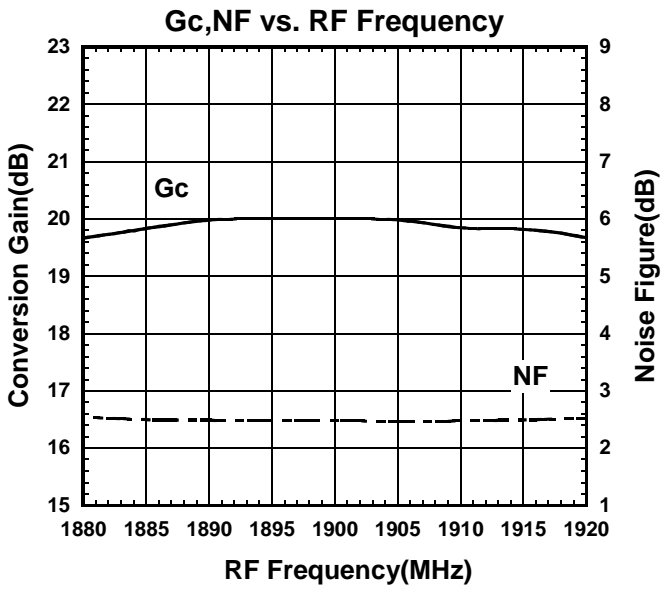

Condition
 $f_{IF}=240\text{MHz}$
 $f_{RF}=1880\sim 1920\text{MHz}$, $P_{RF}=-45\text{dBm}$
 Lower LOCAL, $P_{LO}=-15\text{dBm}$
 $V_{CTL1}=0\text{V}$, $V_{CTL2}=2.7\text{V}$
 $V_{LNA}=V_{MIX}=V_{LO}=2.7\text{V}$

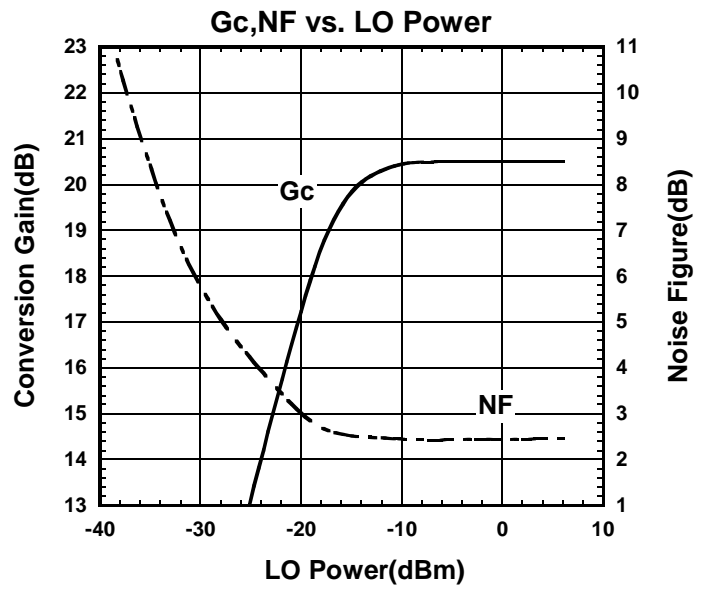

Condition
 $f_{IF}=240\text{MHz}$
 $f_{RF}=1900\text{MHz}$, $P_{RF}=-45\text{dBm}$
 $f_{LO}=1660\text{MHz}$
 $V_{CTL1}=0\text{V}$, $V_{CTL2}=2.7\text{V}$
 $V_{LNA}=V_{MIX}=V_{LO}=2.7\text{V}$

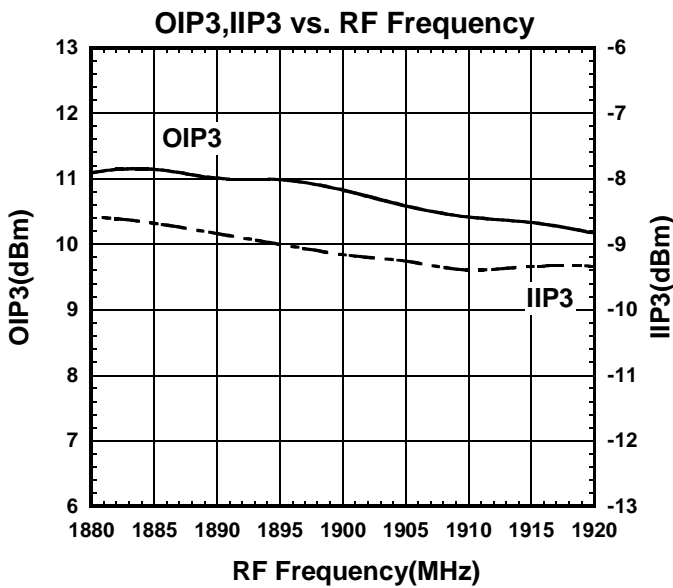

Condition
 $f_{IF}=240\text{MHz}$
 $f_{RF}=1880\sim 1920\text{MHz}$, $P_{RF}=-40\text{dBm}$
 $f_{RF\text{ OFFSET}}=600\text{kHz}$
 Lower LOCAL, $P_{LO}=-15\text{dBm}$
 $V_{CTL1}=0\text{V}$, $V_{CTL2}=2.7\text{V}$
 $V_{LNA}=V_{MIX}=V_{LO}=2.7\text{V}$

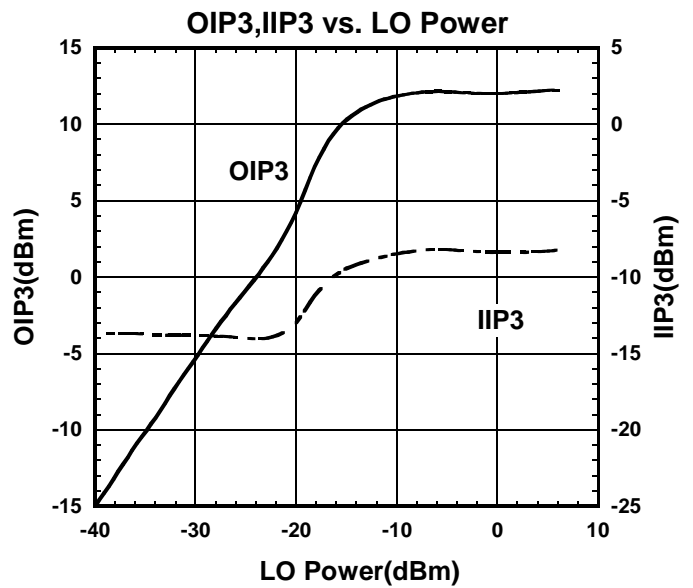

Condition
 $f_{IF}=240\text{MHz}$
 $f_{RF}=1900.0+1900.6\text{MHz}$, $P_{RF}=-40\text{dBm}$
 $f_{LO}=1660\text{MHz}$
 $V_{CTL1}=0\text{V}$, $V_{CTL2}=2.7\text{V}$
 $V_{LNA}=V_{MIX}=V_{LO}=2.7\text{V}$

$$\begin{aligned} \text{OIP3} &= (3 \times \text{IF} - \text{IM3}) / 2 \\ \text{IIP3} &= \text{OIP3} - \text{Gc} \end{aligned}$$

NJG1717KT2

■ TYPICAL CHARACTERISTICS (RX: ANT SW + LNA + MIXER SECTION)

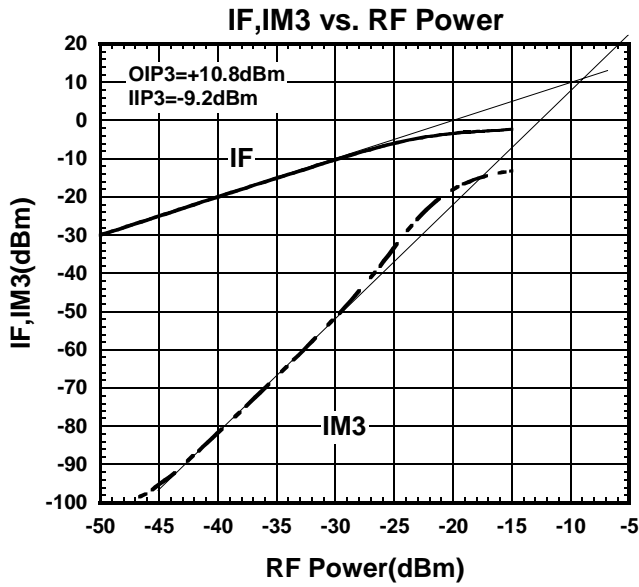

Condition
 $f_{IF}=240\text{MHz}$
 $f_{RF}=1900.0+1900.6\text{MHz}$
 $f_{LO}=1660\text{MHz}$, $P_{LO}=-15\text{dBm}$
 $V_{CTL1}=0\text{V}$, $V_{CTL2}=2.7\text{V}$
 $V_{LNA}=V_{MIX}=V_{LO}=2.7\text{V}$

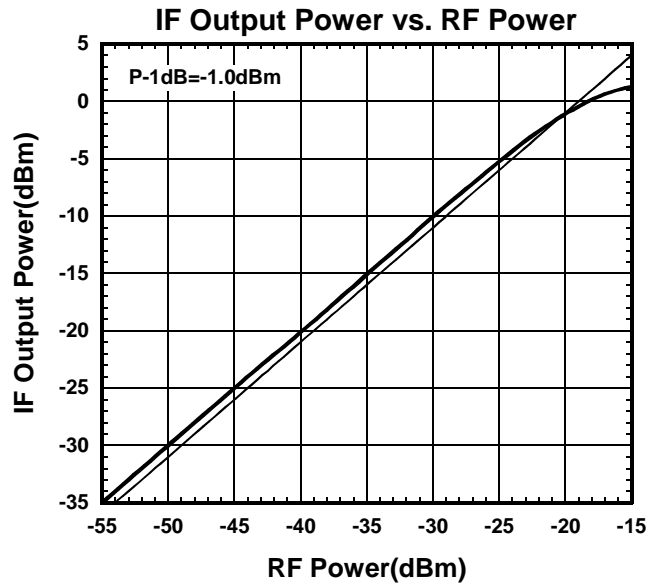

Condition
 $f_{IF}=240\text{MHz}$
 $f_{RF}=1900\text{MHz}$
 $f_{LO}=1660\text{MHz}$, $P_{LO}=-15\text{dBm}$
 $V_{CTL1}=0\text{V}$, $V_{CTL2}=2.7\text{V}$
 $V_{LNA}=V_{MIX}=V_{LO}=2.7\text{V}$

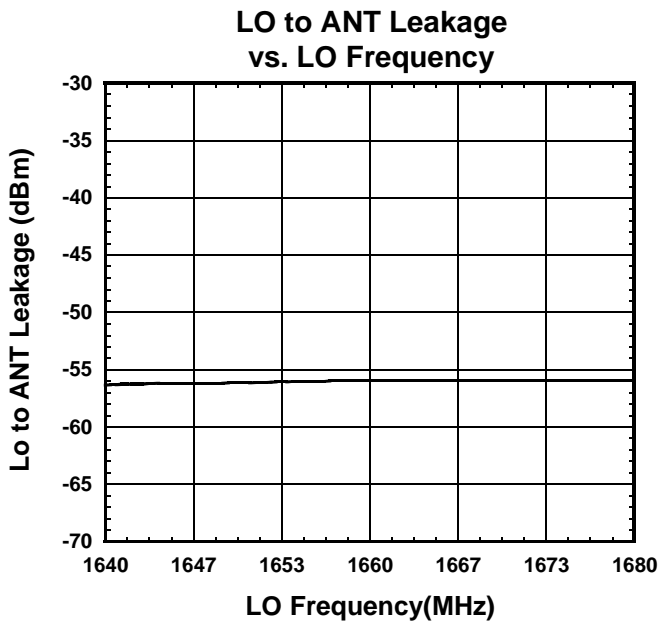

Condition
 IF OUT 50Ω term
 $P_{LO}=-15\text{dBm}$
 $V_{CTL1}=0\text{V}$, $V_{CTL2}=2.7\text{V}$
 $V_{LNA}=V_{MIX}=V_{LO}=2.7\text{V}$

■ TYPICAL CHARACTERISTICS (RX: ANT SW + LNA + MIXER SECTION)

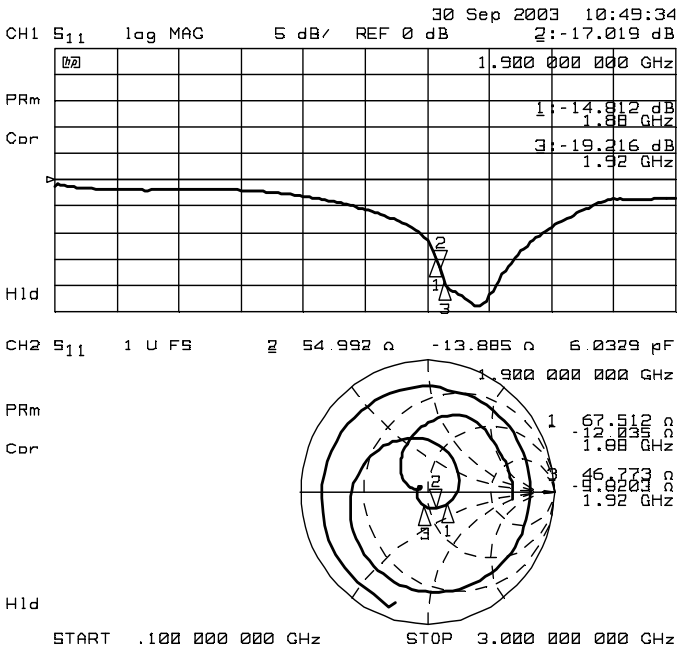

ANT Impedance Condition
 P_{LO}=-15dBm
 IF OUT 50Ω term
 V_{CTL1}=0V, V_{CTL2}=2.7V
 V_{LNA}=V_{MIX}=V_{LO}=2.7V

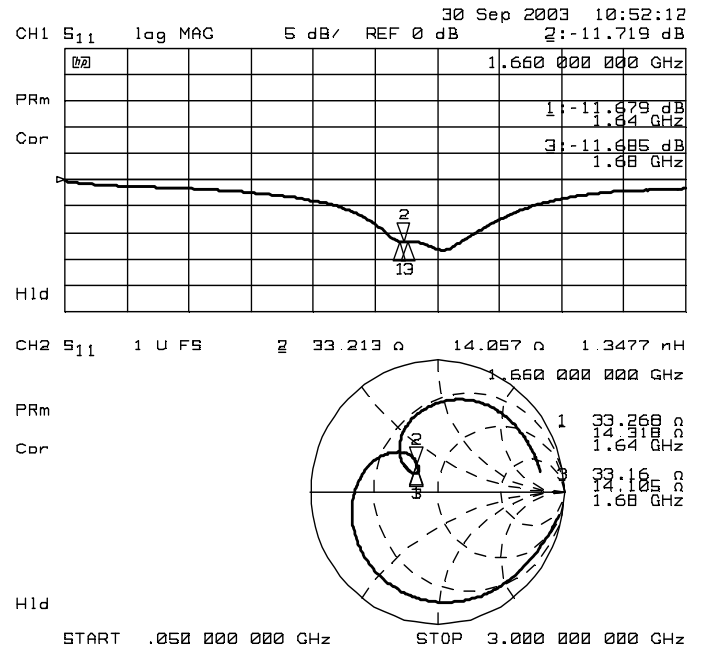

LOCAL IN Impedance Condition
 ANT, IF OUT 50Ω term
 V_{CTL1}=0V, V_{CTL2}=2.7V
 V_{LNA}=V_{MIX}=V_{LO}=2.7V

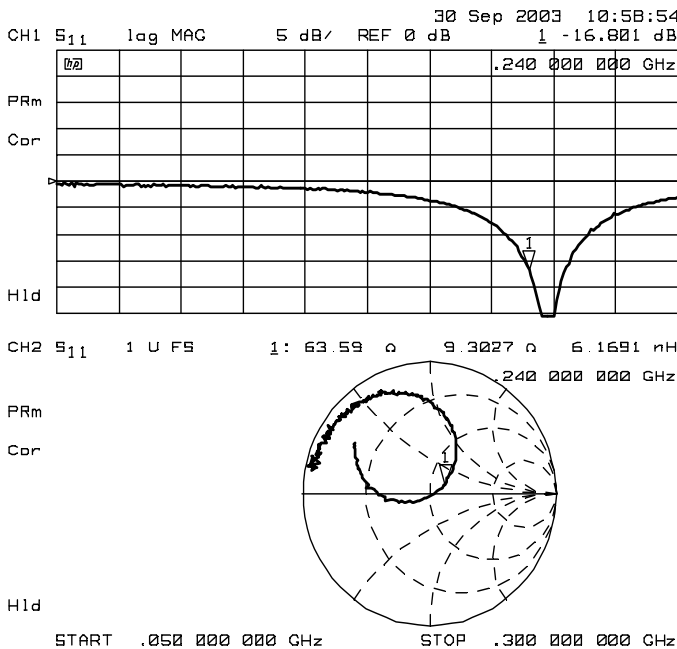

IF OUT Impedance Condition
 P_{LO}=-15dBm
 ANT 50Ω term
 V_{CTL1}=0V, V_{CTL2}=2.7V
 V_{LNA}=V_{MIX}=V_{LO}=2.7V

NJG1717KT2

■ TYPICAL CHARACTERISTICS (RX: ANT SW + LNA + MIXER SECTION)

Conversion Gain , Noise Figure
vs. V_{LNA} , V_{MIX} , V_{LO}

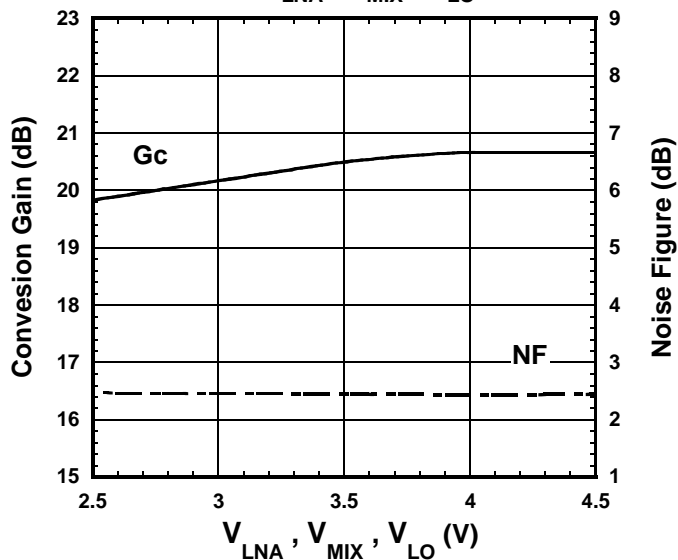

Condition
 $f_{IF}=240\text{MHz}$
 $f_{RF}=1900\text{MHz}$, $P_{RF}=-45\text{dBm}$
 $f_{LO}=1660\text{MHz}$, $P_{LO}=-15\text{dBm}$
 $V_{CTL1}=0\text{V}$

OIP3 , IIP3 vs. V_{LNA} , V_{MIX} , V_{LO}

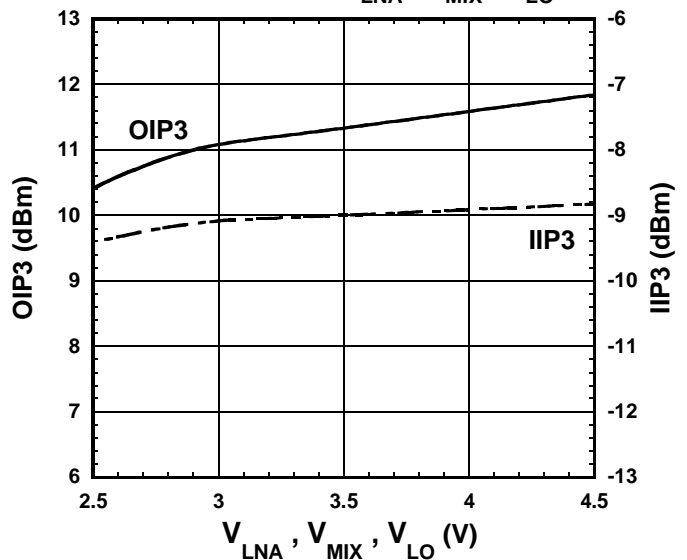

Condition
 $f_{IF}=240\text{MHz}$
 $f_{RF}=1900\text{MHz}$, $P_{RF}=-40\text{dBm}$
 $f_{LO}=1660\text{MHz}$, $P_{LO}=-15\text{dBm}$
 $V_{CTL1}=0\text{V}$

P-1dB vs. V_{LNA} , V_{MIX} , V_{LO}

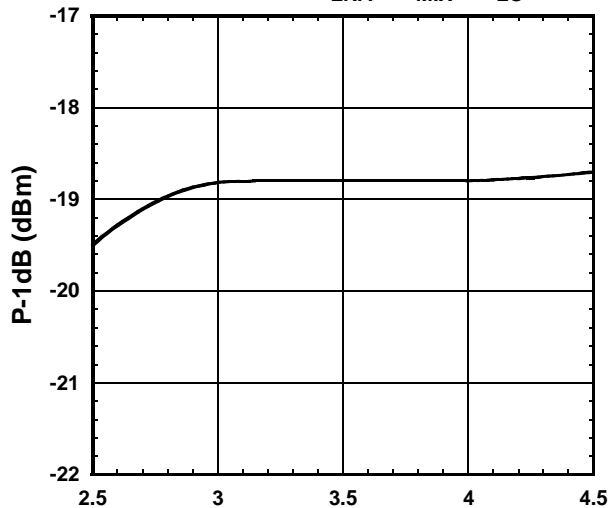

Condition
 $f_{IF}=240\text{MHz}$
 $f_{RF}=1900\text{MHz}$, $P_{RF}=-45\text{dBm}$
 $f_{LO}=1660\text{MHz}$, $P_{LO}=-15\text{dBm}$
 $V_{CTL1}=0\text{V}$

I_{LNA}, I_{MIX}, I_{LO} vs. V_{LNA} , V_{MIX} , V_{LO}

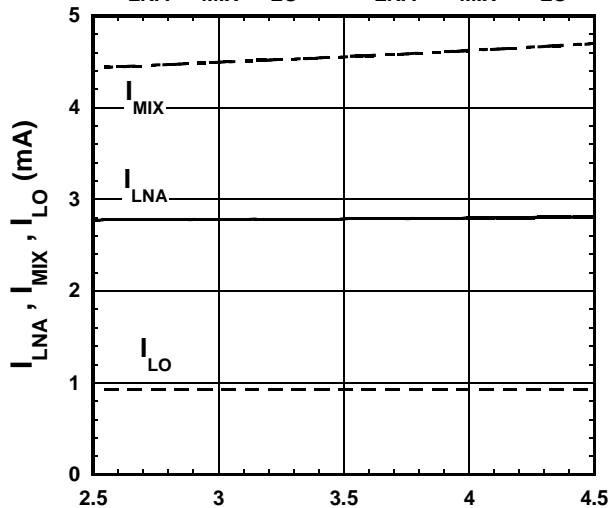

Condition
 $f_{IF}=240\text{MHz}$
 $f_{RF}=1900\text{MHz}$, $P_{RF}=-45\text{dBm}$
 $f_{LO}=1660\text{MHz}$, $P_{LO}=-15\text{dBm}$
 $V_{CTL1}=0\text{V}$

$$\text{OIP3} = (3 \times \text{IIP3}) / 2$$

$$\text{IIP3} = \text{OIP3} - \text{Gc}$$

■ TYPICAL CHARACTERISTICS (RX: ANT SW + LNA + MIXER SECTION)

Conversion Gain vs. RF frequency Temperature Response

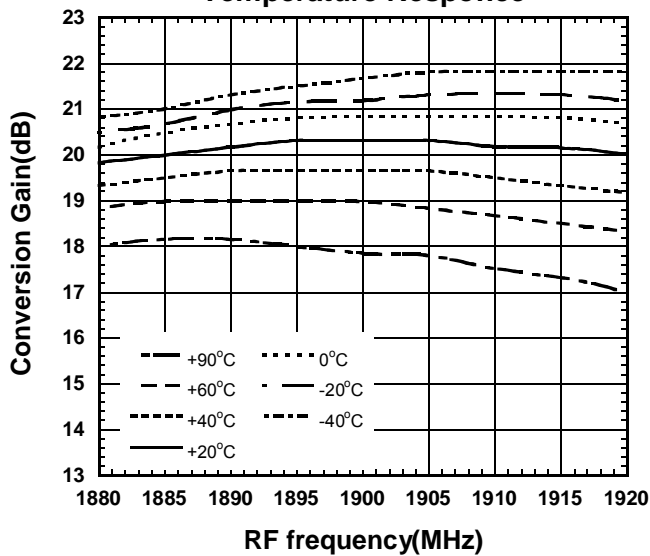

Noise Figure vs. RF frequency Temperature Response

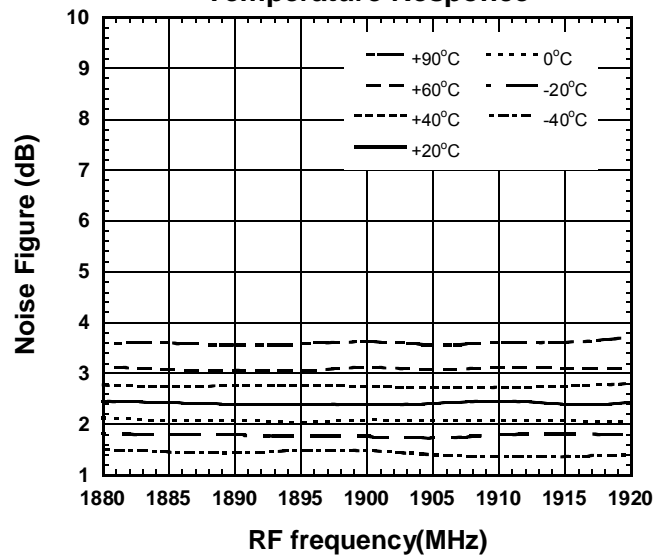

IIP3 vs. RF frequency Temperature Response

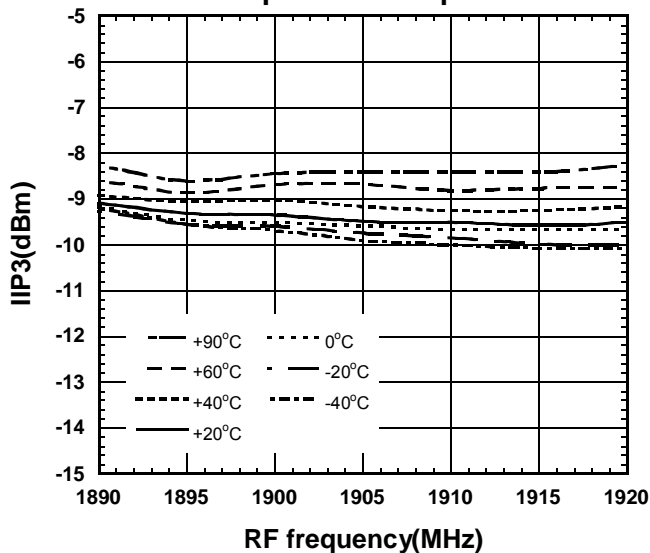

$$\text{OIP3}=(3\times\text{IIP3})/2$$

$$\text{IIP3}=\text{OIP3}-\text{Gc}$$

NJG1717KT2

■ TYPICAL CHARACTERISTICS (RX: ANT SW + LNA + MIXER SECTION)

Conversion Gain vs. LO Power
Temperature Response

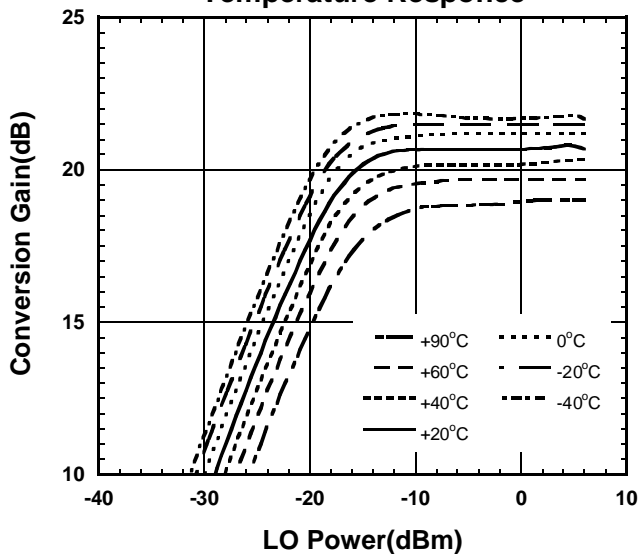

Condition
 $f_{IF}=240\text{MHz}$
 $f_{RF}=1900\text{MHz}$, $P_{RF}=-45\text{dBm}$
 $f_{LO}=1660\text{MHz}$
 $V_{CTL1}=0\text{V}$, $V_{CTL2}=2.7\text{V}$
 $V_{LNA}=V_{MIX}=V_{LO}=2.7\text{V}$

Noise Figure vs. LO Power
Temperature Response

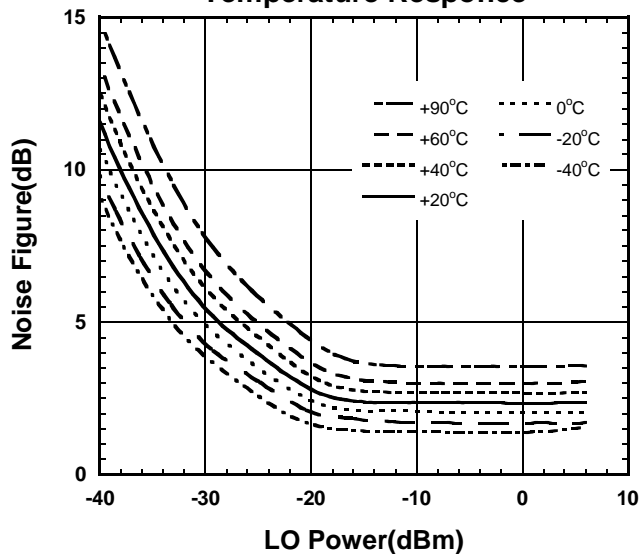

Condition
 $f_{IF}=240\text{MHz}$
 $f_{RF}=1900\text{MHz}$
 $f_{LO}=1660\text{MHz}$
 $V_{CTL1}=0\text{V}$, $V_{CTL2}=2.7\text{V}$
 $V_{LNA}=V_{MIX}=V_{LO}=2.7\text{V}$

IIP3 vs. LO Power
Temperature Response

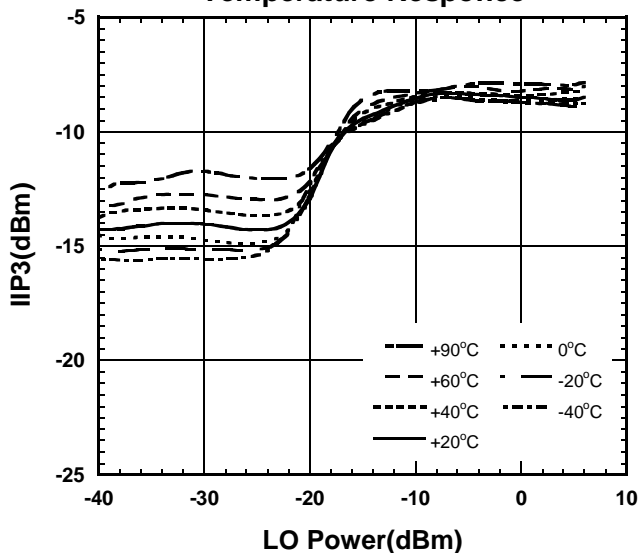

Condition
 $f_{IF}=240\text{MHz}$
 $f_{RF}=1900\text{MHz}$, $P_{RF}=-40\text{dBm}$
 $f_{RF\text{ OFFSET}}=600\text{kHz}$
 $f_{LO}=1660\text{MHz}$
 $V_{CTL1}=0\text{V}$, $V_{CTL2}=2.7\text{V}$
 $V_{LNA}=V_{MIX}=V_{LO}=2.7\text{V}$

I_{LNA} , I_{MIX} , I_{LO} vs. Temperature

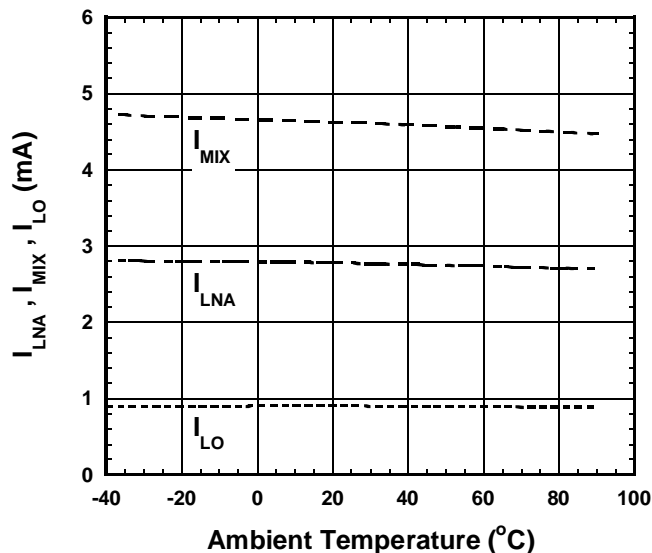

Condition
 $V_{LNA}=V_{MIX}=V_{LO}=2.7\text{V}$

$$\text{OIP3}=(3 \times \text{IIP3})/2$$

$$\text{IIP3}=\text{OIP3}-\text{Gc}$$

■ TYPICAL CHARACTERISTICS (RX: ANT SW + LNA + MIXER SECTION)

ANT to LOCAL IN K factor vs. Frequency
Temperature Response

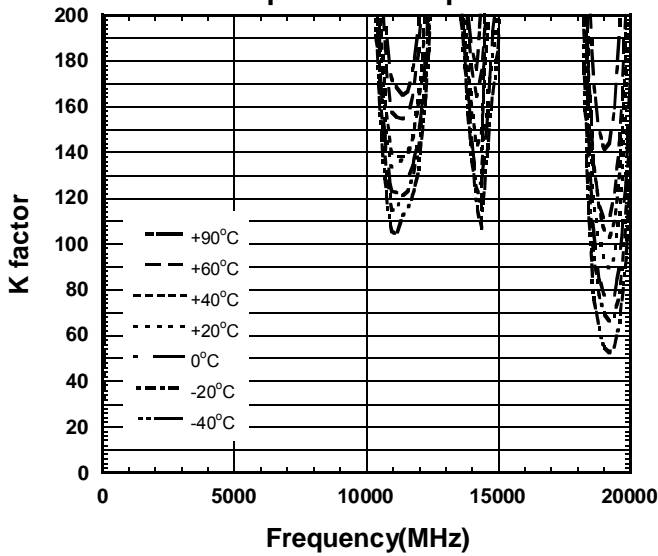

Condition
 IF OUT 50Ω term
 $V_{CTL1}=0V, V_{CTL2}=2.7V$
 $V_{LNA}=V_{MIX}=V_{LO}=2.7V$

LOCAL IN to IF OUT K factor vs. Frequency
Temperature Response

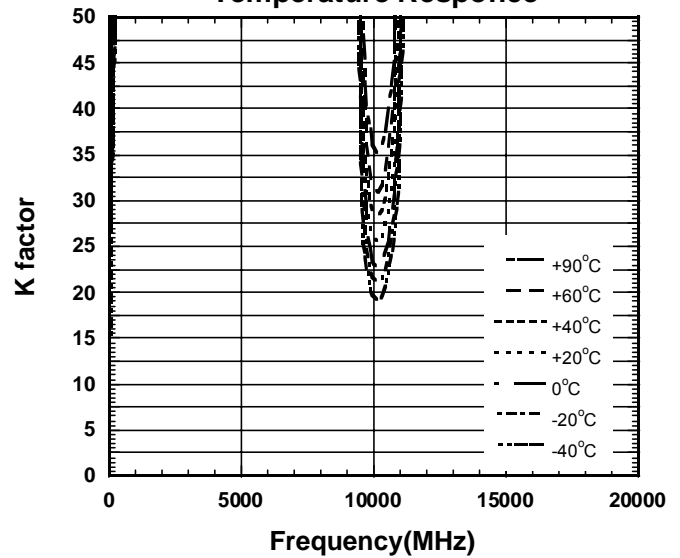

Condition
 ANT 50Ω term
 $V_{CTL1}=0V, V_{CTL2}=2.7V$
 $V_{LNA}=V_{MIX}=V_{LO}=2.7V$

ANT to IF OUT K factor vs. Frequency
Temperature Response

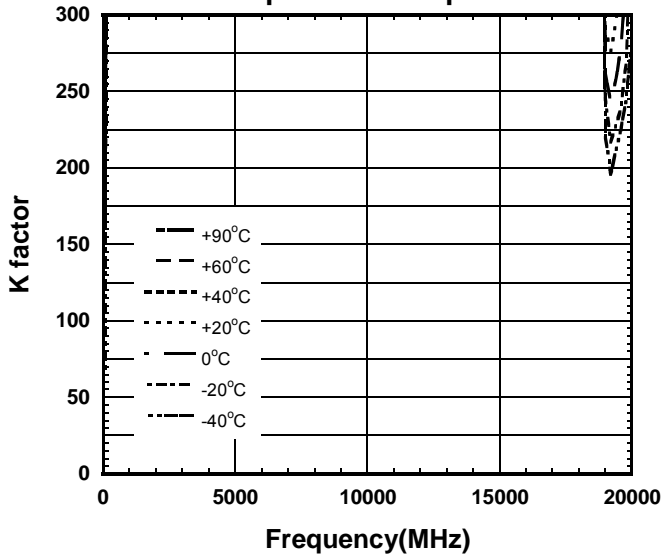

Condition
 LOCAL IN 50Ω term
 $V_{CTL1}=0V, V_{CTL2}=2.7V$
 $V_{LNA}=V_{MIX}=V_{LO}=2.7V$

NJG1717KT2

TEST CIRCUIT

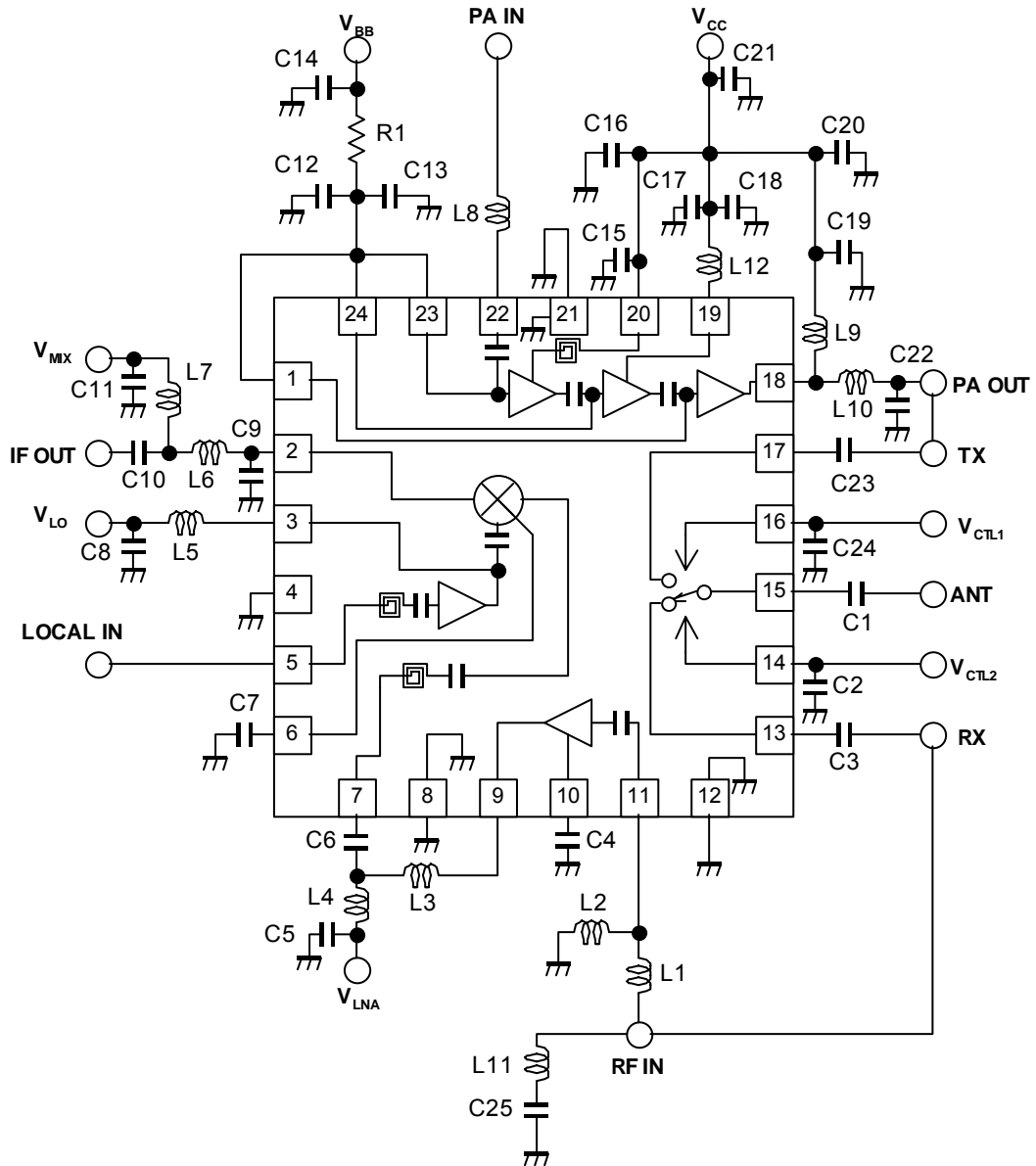

■ PARTS LIST

| PART ID | 1900MHzBAND | REMARKS |
|---------|--|----------------------|
| | Lower LOCAL | |
| | $f_{LO}=1660\text{MHz}$, $f_{IF}=240\text{MHz}$ | |
| L1 | 6.8nH | TAIYO-YUDEN (HK1005) |
| L2 | 22nH | TAIYO-YUDEN (HK1005) |
| L3 | 3.9nH | TAIYO-YUDEN (HK1005) |
| L4 | 1.5nH | TAIYO-YUDEN (HK1005) |
| L5 | 6.8nH | TAIYO-YUDEN (HK1005) |
| L6 | 39nH | TAIYO-YUDEN (HK1608) |
| L7 | 22nH | TAIYO-YUDEN (HK1005) |
| L8 | 4.7nH | TAIYO-YUDEN (HK1005) |
| L9 | 18nH | TAIYO-YUDEN (HK1608) |
| L10 | 1nH | TAIYO-YUDEN (HK1005) |
| L11 | 6.8nH | TAIYO-YUDEN (HK1005) |
| L12 | 1.2nH | TAIYO-YUDEN (HK1005) |
| C1 | 56pF | MURATA (GRP15) |
| C2 | 10pF | MURATA (GRP15) |
| C3 | 56pF | MURATA (GRP15) |
| C4 | 1000pF | MURATA (GRP15) |
| C5 | 1000pF | MURATA (GRP15) |
| C6 | 4pF | MURATA (GRP15) |
| C7 | 1000pF | MURATA (GRP15) |
| C8 | 0.01 μ F | MURATA (GRP15) |
| C9 | 6pF | MURATA (GRP15) |
| C10 | 1000pF | MURATA (GRP15) |
| C11 | 0.01 μ F | MURATA (GRP15) |
| C12 | 33pF | MURATA (GRP15) |
| C13 | 0.1 μ F | MURATA (GRP15) |
| C14 | 1 μ F | MURATA (GRM18) |
| C15 | 33pF | MURATA (GRP15) |
| C16 | 0.01 μ F | MURATA (GRP15) |
| C17 | 33pF | MURATA (GRP15) |
| C18 | 0.01 μ F | MURATA (GRP15) |
| C19 | 33pF | MURATA (GRP15) |
| C20 | 0.01 μ F | MURATA (GRP15) |
| C21 | 1 μ F | MURATA (GRM18) |
| C22 | 2pF | MURATA (GRP15) |
| C23 | 56pF | MURATA (GRP15) |
| C24 | 10pF | MURATA (GRP15) |
| C25 | 2pF | MURATA (GRP15) |
| R1 | 150 Ω | 1005SIZE |

NJG1717KT2

■ APPLIED CIRCUIT BOARD EXAMPLES

(Top View)

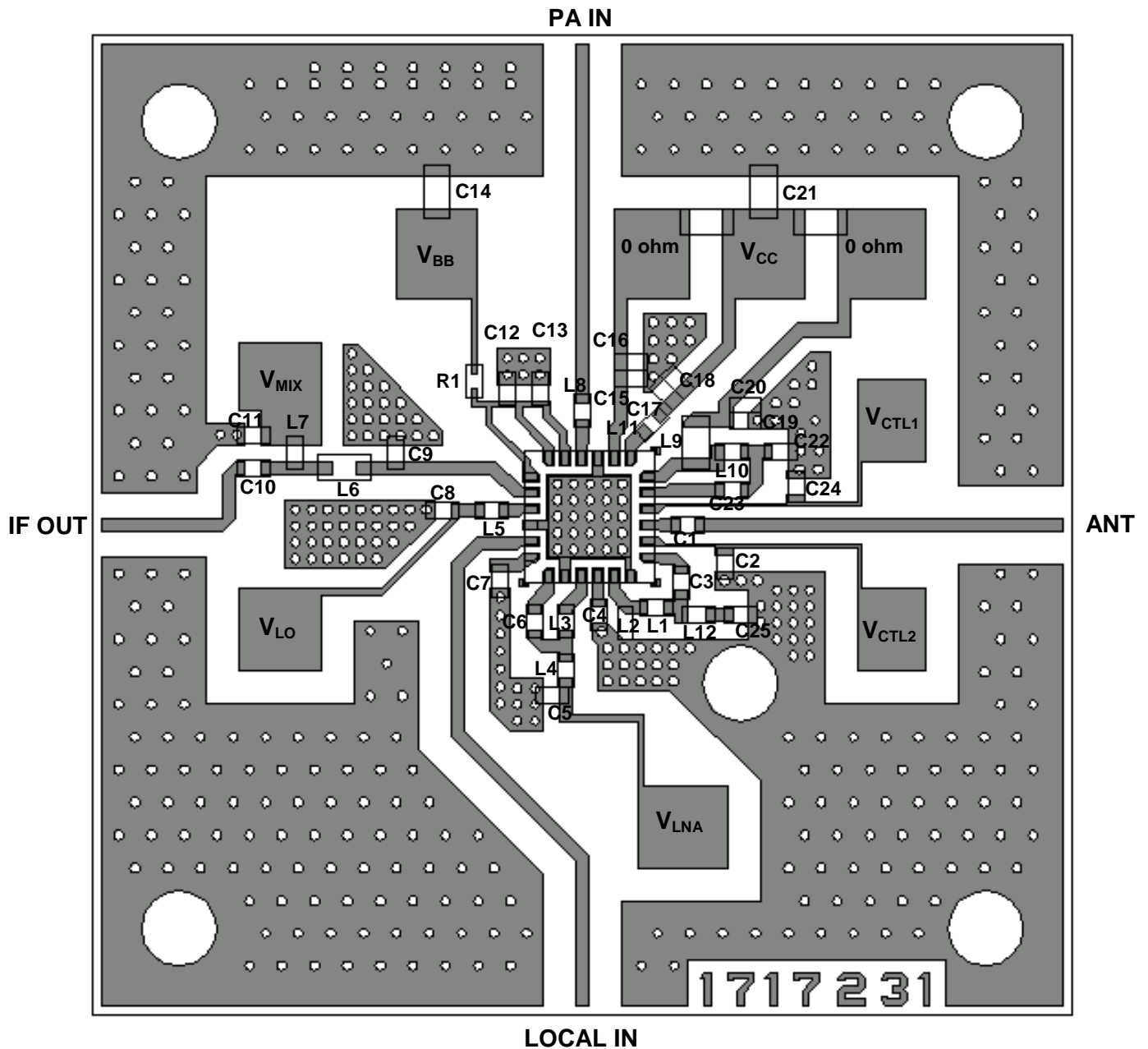

PCB (FR-4), t=0.2mm

MICROSTRIP LINE WIDTH=0.4mm($Z_0=50\Omega$)

PRECAUTIONS

1. Please locate L1 close to LNAIN terminal (11).
2. Please locate C4 close to LNACAP terminal (10).
3. Please locate L5 close to VLO terminal (3).
4. Please locate C8 close to L5.
5. Please connect exposed GND PAD (bottom side of IC) to PCB GND using through holes as many as possible.
6. Please design the PCB structure that the dielectric thickness between the surface layer and the GND layer (directly under) is set to 0.2mm or more, about PCB of this device and external parts. However, the terminal of TAB GND of this device and the GND of external parts does not have these restrictions. Please design the GND layer pattern that can reduce a parasitic GND inductance as much as possible.

MEASUREMENT BLOCK DIAGRAM (TX: PA + ANT SW SECTION)

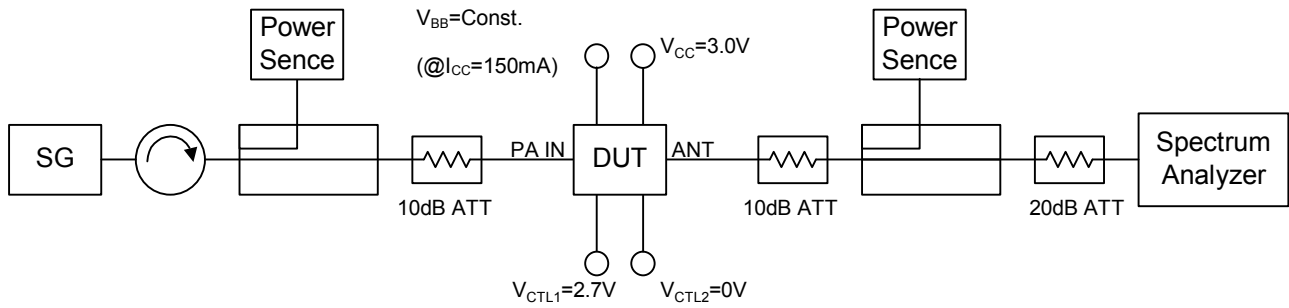

Tx mode (PA+ANT SW) Measurement Block Diagram

MEASUREMENT BLOCK DIAGRAM (RX: ANT SW + LNA + MIXER SECTION)

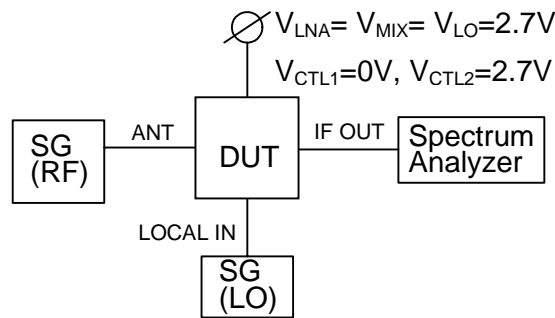

Conversion Gain Measurement Block Diagram

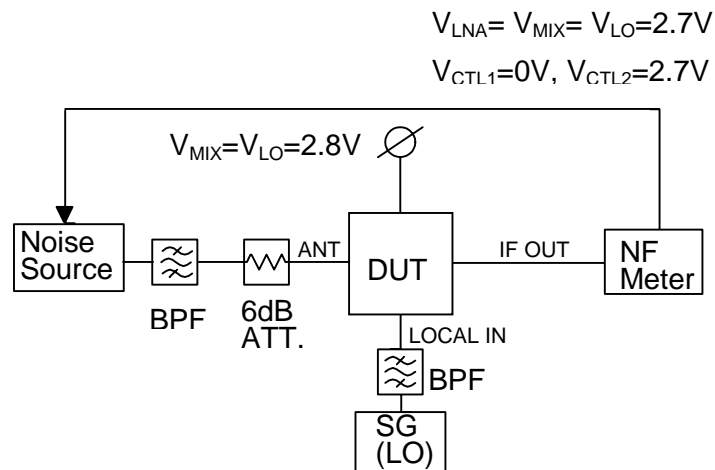

Noise Figure Measurement Block Diagram

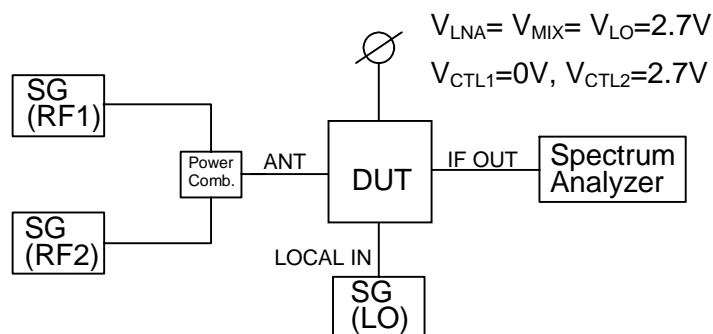

IF and IM3 measurement Block Diagram for IIP3

■PACKAGE OUTLINE (QFN24-T2: 0.5pitch)

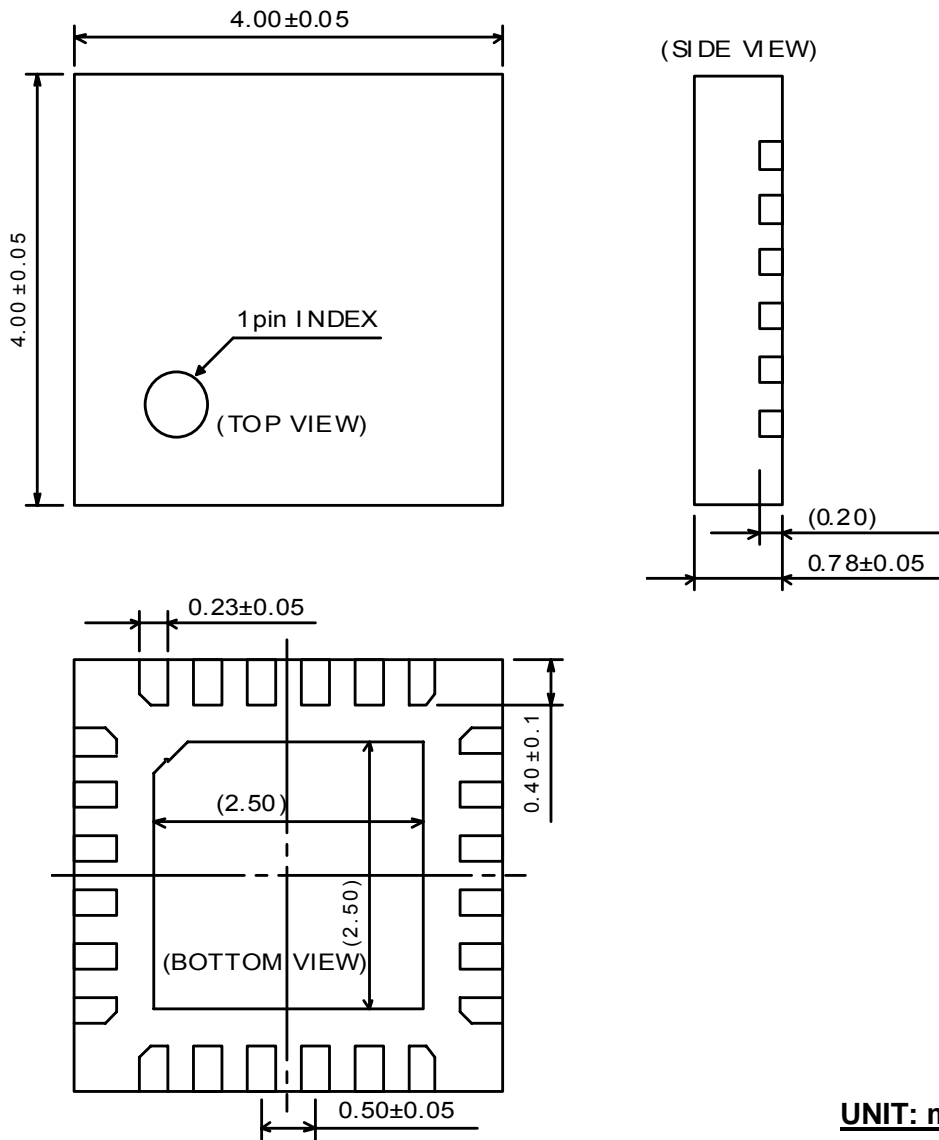

UNIT: mm

Cautions on using this product

- This product contains Gallium-Arsenide (GaAs) which is a harmful material.
- Do NOT eat or put into mouth.
 - Do NOT dispose in fire or break up this product.
 - Do NOT chemically make gas or powder with this product.
 - To waste this product, please obey the relating law of your country.

[CAUTION]

The specifications on this databook are only given for information, without any guarantee as regards either mistakes or omissions. The application circuits in this databook are described only to show representative usages of the product and not intended for the guarantee or permission of any right including the industrial rights.

This product may be damaged with electric static discharge (ESD) or spike voltage. Please handle with care to avoid these damages.