

HIGH OUTPUT CURRENT C-MOS 3-TERMINAL VOLTAGE REGULATOR

■ GENERAL DESCRIPTION

The **NJU7202 series** is a high output current C-MOS 3-terminal positive voltage regulator which contains internal accurate voltage reference, error amplifier, control transistor, output voltage setting resistor and short current protection circuit.

The regulation voltage is fixed by internal circuits and the following line-up of different output voltage versions are available.

The short current protection circuit prevents destruction of a element by careless great current output in short circuit.

The **NJU7202 series** is suitable for battery operated items and battery back-up systems because of low operating current and low dropout voltage.

■ FEATURES

- High Output Current $I_o = 100\text{mA}$
- Low Operating Current $20\mu\text{A typ}$
- Low Dropout Voltage $\Delta V_{IO} < 0.6\text{V @ } I_o = 100\text{mA}$
- Wide Operating Voltage Range
- Small Temperature Coefficient of Output Voltage
- Short Current Protection Circuit
- Package Outline TO-92/SOT-89
- C-MOS Technology

■ OUTPUT VOLTAGE LINE-UP

Output Voltage	TO-92 Type	SOT-89 Type
+3.0V	NJU7202L30	NJU7202U30
+3.3V	NJU7202L33	NJU7202U33
+5.0V	NJU7202L50	NJU7202U50

Note1) The SOT-89 type name is different from the marking, so it refer to attached paper correspondence table.

■ EQUIVALENT CIRCUIT

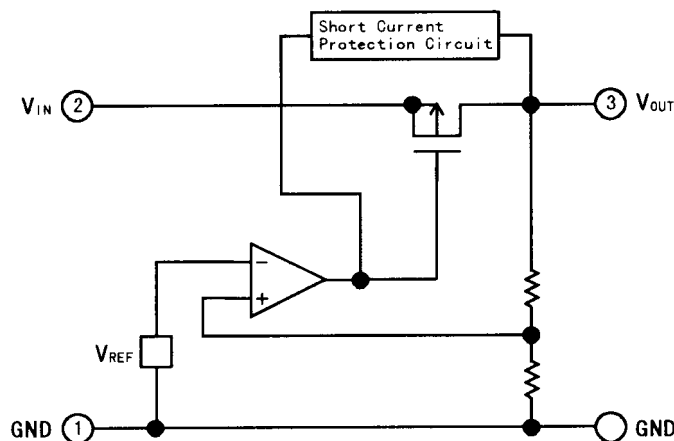

■ PACKAGE OUTLINE



NJU7202L

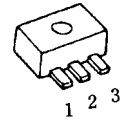

NJU7202U

■ TERMINAL DESCRIPTION

No.	Description
1	GND
2	Input
3	Output

NJU7202 Series

■ ABSOLUTE MAXIMUM RATINGS

($T_a = 25^\circ\text{C}$)

PARAMETER	SYMBOL	RATINGS	UNIT
Input Voltage	V_{IN}	15	V
Output Voltage	V_{OUT}	GND-0.3 to $V_{IN}+0.3$	V
Output Current	I_{OUT}	200	mA
Power Dissipation	P_D	500 (TO-92) 300 (SOT-89)	mW
Operating Temperature	T_{opr}	-25 to +75	$^\circ\text{C}$
Storage Temperature	T_{stg}	-40 to +125	$^\circ\text{C}$

■ ELECTRICAL CHARACTERISTICS

+3.0V Version

($C_{IN} = C_O = 0.1\mu\text{F}$, $T_a = 25^\circ\text{C}$)

PARAMETER	SYMBOL	CONDITION	MIN.	TYP.	MAX.	UNIT
Output Voltage	V_{OUT}	$V_{IN} = 5.0\text{V}$, $I_{OUT} = 70\text{mA}$	2.85	3.00	3.15	V
Dropout Voltage	ΔV_{IO}	$I_{OUT} = 50\text{mA}$	-	0.4	0.6	V
Input Voltage	V_{IN}		-	-	14	V
Operating Current	I_{DD1}	$V_{IN} = 5.0\text{V}$	-	20	30	μA
Load Regulation	$\frac{\Delta V_{OUT}}{\Delta I_{OUT}}$	$V_{IN} = 5.0\text{V}$, $I_{OUT} = 1$ to 100mA	-	120	160	mV
Line Regulation	$\frac{\Delta V_{OUT}}{\Delta V_{IN} \cdot V_{OUT}}$	$V_{IN} = 4.0$ to 12.0V	-	0.1	-	%/V

+3.3V Version

($C_{IN} = C_O = 0.1\mu\text{F}$, $T_a = 25^\circ\text{C}$)

PARAMETER	SYMBOL	CONDITION	MIN.	TYP.	MAX.	UNIT
Output Voltage	V_{OUT}	$V_{IN} = 5.3\text{V}$, $I_{OUT} = 70\text{mA}$	3.135	3.300	3.465	V
Dropout Voltage	ΔV_{IO}	$I_{OUT} = 50\text{mA}$	-	0.4	0.6	V
Input Voltage	V_{IN}		-	-	14	V
Operating Current	I_{DD1}	$V_{IN} = 5.3\text{V}$	-	20	30	μA
Load Regulation	$\frac{\Delta V_{OUT}}{\Delta I_{OUT}}$	$V_{IN} = 5.3\text{V}$, $I_{OUT} = 1$ to 100mA	-	120	160	mV
Line Regulation	$\frac{\Delta V_{OUT}}{\Delta V_{IN} \cdot V_{OUT}}$	$V_{IN} = 4.3$ to 12.0V	-	0.1	-	%/V

+5.0V Version

($C_{IN} = C_O = 0.1\mu\text{F}$, $T_a = 25^\circ\text{C}$)

PARAMETER	SYMBOL	CONDITION	MIN.	TYP.	MAX.	UNIT
Output Voltage	V_{OUT}	$V_{IN} = 7.0\text{V}$, $I_{OUT} = 70\text{mA}$	4.75	5.00	5.25	V
Dropout Voltage	ΔV_{IO}	$I_{OUT} = 100\text{mA}$	-	0.3	0.6	V
Input Voltage	V_{IN}		-	-	14	V
Operating Current	I_{DD1}	$V_{IN} = 7.0\text{V}$	-	20	30	μA
Load Regulation	$\frac{\Delta V_{OUT}}{\Delta I_{OUT}}$	$V_{IN} = 7.0\text{V}$, $I_{OUT} = 1$ to 100mA	-	120	160	mV
Line Regulation	$\frac{\Delta V_{OUT}}{\Delta V_{IN} \cdot V_{OUT}}$	$V_{IN} = 6.0$ to 12.0V	-	0.1	-	%/V

■ MEASUREMENT CIRCUIT

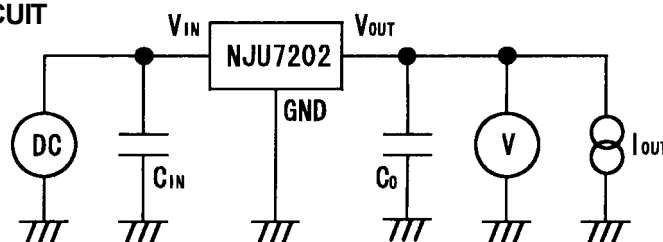

[CAUTION]

The specifications on this databook are only given for information, without any guarantee as regards either mistakes or omissions. The application circuits in this databook are described only to show representative usages of the product and not intended for the guarantee or permission of any right including the industrial rights.