

DATA SHEET

DL4728A~DL4764A

Pb Free Product

SURFACE MOUNT ZENER DIODES

VOLTAGE 3.3 to 100 Volts

POWER 1.0 Watts

MELF/DL-41

Unit : inch (mm)

FEATURES

- Low profile package
- Built-in strain relief
- Low inductance

MECHANICAL DATA

- Case: Molded Glass MELF / DL-41
- Terminals: Solderable per MIL-STD-202E, Method 208
- Polarity: See Diagram Below
- Approx. Weight: 0.16 grams
- Mounting Position: Any
- Packing information

T/R - 5K per 13" paper Reel

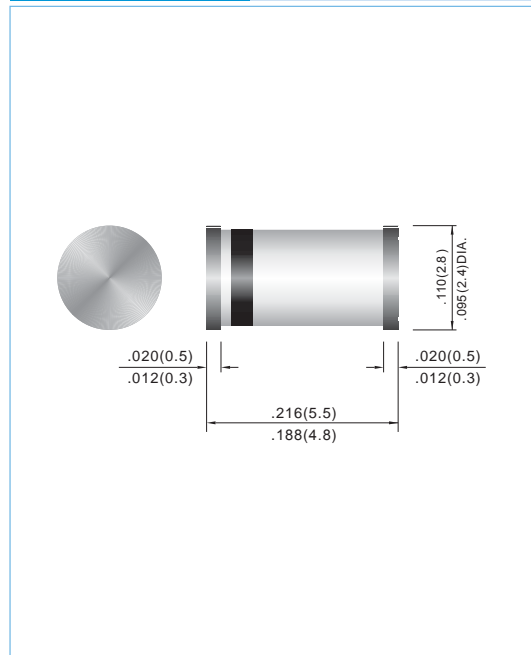

MAXIMUM RATINGS AND ELECTRICAL CHARACTERISTICS

Ratings at 25°C ambient temperature unless otherwise specified.

Parameter	Symbol	Value	Units
Power Dissipation at Tamb = 25 °C	P _{TOT}	1*	W
Operating Temperature	T _J	-55 to +175	°C
Storage Temperature Range	T _{STG}	-65 to + 200	°C

*Valid provided that leads at a distance of 10mm from case are kept at ambient temperature.

Parameter	Symbol	Min.	Typ.	Max.	Units
Thermal Resistance Junction to Ambient Air	R _{thA}	--	--	170*	K/W
Forward Voltage at I _F = 200mA	V _F	--	--	1.2	V

*Valid provided that leads at a distance of 10mm from case are kept at ambient temperature.

WILLAS

Part Number	Maximum Zener Voltage			Maximum Zener Impedance				Maximum Leakage Current	
	V _Z @ I _{ZT}			Z _{ZT} @ I _{ZT}		Z _{ZK} @ I _{ZK}		I _R @ V _R	
	Nom. V	Min. V	Max. V	Ω	mA	Ω	mA	uA	V
1.0 watt Zener Diodes (Glass Sealed Envelope)									
DL4728A	3.3	3.1	3.5	10.0	76.0	400	1.00	100	1.0
DL4729A	3.6	3.4	3.8	10.0	69.0	400	1.00	100	1.0
DL4730A	3.9	3.7	4.1	9.0	64.0	400	1.00	50	1.0
DL4731A	4.3	4.1	4.5	9.0	58.0	400	1.00	10	1.0
DL4732A	4.7	4.5	4.9	8.0	53.0	500	1.00	10	1.0
DL4733A	5.1	4.8	5.4	7.0	49.0	550	1.00	10	1.0
DL4734A	5.6	5.3	5.9	5.0	45.0	600	1.00	10	2.0
DL4735A	6.2	5.9	6.5	2.0	41.0	700	1.00	10	3.0
DL4736A	6.8	6.5	7.1	3.5	37.0	700	1.00	10	4.0
DL4737A	7.5	7.1	7.9	4.0	34.0	700	0.50	10	5.0
DL4738A	8.2	7.8	8.6	4.5	31.0	700	0.50	10	6.0
DL4739A	9.1	8.6	9.6	5.0	28.0	700	0.50	10	7.0
DL4740A	10.0	9.5	10.5	7.0	25.0	700	0.25	10	7.6
DL4741A	11.0	10.5	11.6	8.0	23.0	700	0.25	5	8.4
DL4742A	12.0	11.4	12.6	9.0	21.0	700	0.25	5	9.1
DL4743A	13.0	12.4	13.7	10.0	19.0	700	0.25	5	9.9
DL4744A	15.0	14.3	15.8	14.0	17.0	700	0.25	5	11.4
DL4745A	16.0	15.2	16.8	16.0	15.5	700	0.25	5	12.2
DL4746A	18.0	17.1	18.9	20.0	14.0	750	0.25	5	13.7
DL4747A	20.0	19.0	21.0	22.0	12.5	750	0.25	5	15.2
DL4748A	22.0	20.9	23.1	23.0	11.5	750	0.25	5	16.7
DL4749A	24.0	22.8	25.2	25.0	10.5	750	0.25	5	18.2
DL4750A	27.0	25.7	28.4	35.0	9.5	750	0.25	5	20.6
DL4751A	30.0	28.5	31.5	40.0	8.5	1000	0.25	5	22.8
DL4752A	33.0	31.4	34.7	45.0	7.5	1000	0.25	5	25.1
DL4753A	36.0	34.2	37.8	50.0	7.0	1000	0.25	5	27.4
DL4754A	39.0	37.1	41.0	60.0	6.5	1000	0.25	5	29.7
DL4755A	43.0	40.9	45.2	70.0	6.0	1500	0.25	5	32.7
DL4756A	47.0	44.7	49.4	80.0	5.5	1500	0.25	5	35.8
DL4757A	51.0	48.5	53.6	95.0	5.0	1500	0.25	5	38.8
DL4758A	56.0	53.2	58.8	110.0	4.5	2000	0.25	5	42.6
DL4759A	62.0	58.9	65.1	125.0	4.0	2000	0.25	5	47.1
DL4760A	68.0	64.6	71.4	150.0	3.7	2000	0.25	5	51.7
DL4761A	75.0	71.3	78.8	175.0	3.3	2000	0.25	5	56.0
DL4762A	82.0	77.9	86.1	200.0	3.0	3000	0.25	5	62.2
DL4763A	91.0	86.5	95.6	250.0	2.8	3000	0.25	5	69.2
DL4764A	100.0	95.0	105.0	350.0	2.5	3000	0.25	5	76.0

WILLAS

RATING AND CHARACTERISTIC CURVES

