

DN8798MS

3 V operation Hall IC

■ Overview

The DN8798MS is a 3 V operation Hall IC which includes a Hall element, amplifier circuit, Schmidt circuit, stabilized power supply and temperature compensation circuit which are integrated on a single chip with a fine patterning technology. The magnetic input signal is outputted by being converted to high or low. We have improved the conventional circuit to realize a stable operation covering from low to high supply voltage and from low to high temperature.

■ Features

- Wide operating supply voltage range
($V_{CC} = 2.7 \text{ V to } 14.4 \text{ V}$)
- Wide operating ambient temperature ($-40^{\circ}\text{C to } +85^{\circ}\text{C}$)
- Package: Mini type (3-pin type)
(1.1 mm thick: Same as a standard transistor)

■ Applications

- DC brushless motor, fan motor, rotation sensor, detection of cover open/close (example for a cellular phone), position sensor

■ Block Diagram

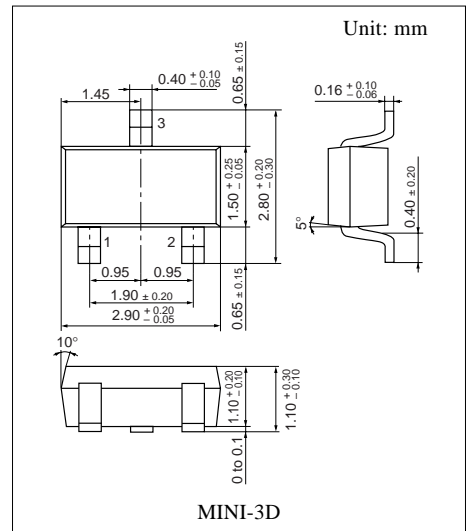
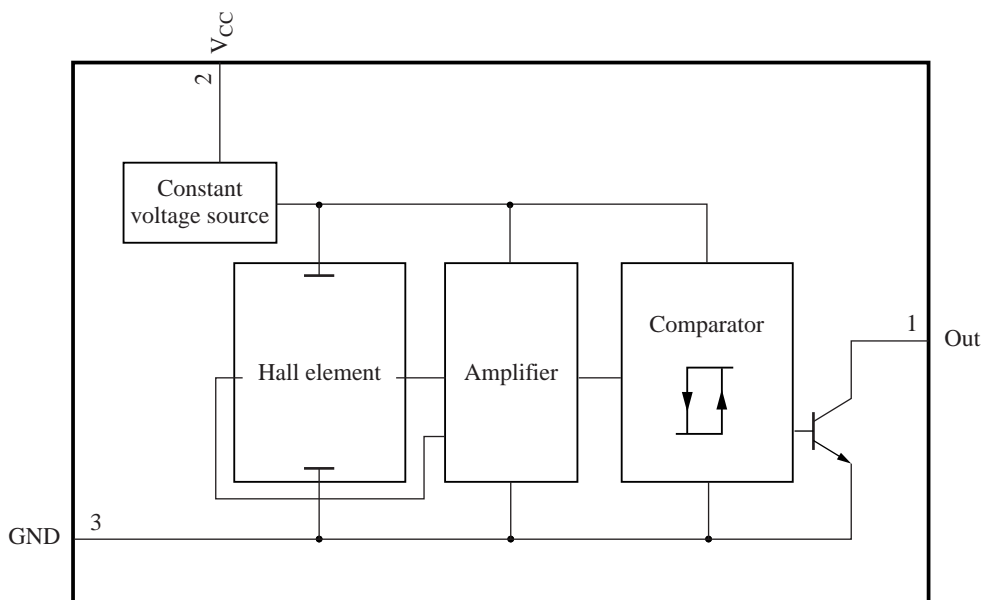

■ Pin Descriptions

Pin No.	Symbol	Description
1	Out	Output pin
2	V _{CC}	Supply voltage pin
3	GND	Ground pin

■ Absolute Maximum Ratings

Parameter	Symbol	Rating	Unit
Supply voltage	V _{CC}	18	V
	V _{OUT}	18	
Supply current	I _{CC}	—	mA
Power dissipation	P _D	120	mW
Operating ambient temperature	T _{opr}	-40 to +85	°C
Storage temperature	T _{stg}	-55 to +125	°C

Note) 1. Except for the operating ambient temperature and storage temperature, all ratings are for T_a = 25°C.

- The reverse insertion of this IC will cause its breakdown.
- It will operate normally in several tens of ms after power on.
- This IC is designed for a general use and if you want to use for an automotive use, please consult our staff of the nearby sales office beforehand.

■ Recommended Operating Range

Parameter	Symbol	Range	Unit
Supply voltage	V _{CC}	2.7 to 14.4	V

■ Electrical Characteristics at T_a = 25°C

Parameter	Symbol	Conditions	Min	Typ	Max	Unit
Operating magnetic flux density 1	BH-L	V _{CC} = 3 V	-15	—	—	mT
Operating magnetic flux density 2	BL-H	V _{CC} = 3 V	—	—	15	mT
Hysteresis width	BW	V _{CC} = 3 V	4	8	12	mT
Output voltage 1	V _{OL1}	V _{CC} = 14.4 V, I _O = 5 mA, B = -15 mT	—	0.07	0.30	V
Output voltage 2	V _{OL2}	V _{CC} = 2.7 V, I _O = 5 mA, B = -15 mT	—	0.07	0.30	V
Output current	I _{OH}	V _{CC} = 2.7 V to 14.4 V V _O = 14.4 V, B = 15 mT	—	—	10	μA
Supply current 1	I _{CC1}	V _{CC} = 14.4 V, B = 15 mT	1.0	3.4	6.0	mA
Supply current 2	I _{CC2}	V _{CC} = 2.7 V, B = 15 mT	1.0	2.5	6.0	mA

Note) 1. Symbol BH-L stands for the operating magnetic flux density where its output level varies from high to low.

- Symbol BL-H stands for the operating magnetic flux density where its output level varies from low to high.
- The variation of operating magnetic flux density does not depend on supply voltage due to its built-in stabilized power source. (V_{CC} should be confined to the range of 2.7 V to 14.4 V.)
- A supply current changes by maximum 1 mA when its output level varies from high to low.

■ Caution on use of Hall ICs

As the Hall IC is often used to detect movement, the position of a Hall IC may be changed, and there is the risk of a change in detection level, if exposed to shock or vibration over a long period of time. Secure the IC by applying adhesive to the package or placing in a dedicated case.

1. On mounting of the surface mount type (MINI-3D package)

When mounted on the printed circuit board, the Hall IC may be highly stressed by the warping that may occur from soldering. This may also cause a change in the operating flux density characteristic and a deterioration of its resistance to moisture.



2. On using flux in soldering

Choose a flux which does not include ingredients from halogen group, such as chlorine, fluorine, etc. The ingredients of halogen group may enter where the lead frame and package resin joint, causing corrosion and the disconnection of the aluminum wiring on the surface of an IC chip.

3. On fixing a Hall IC with the holder

When a Hall IC is mounted on the printed circuit board with a holder and the coefficient of expansion of the holder is large, the lead wire of the Hall IC will be stretched and it may give a stress to the Hall IC.

If the lead wire is stressed intensely due to the distortion of holder or board, the adhesives between the package and the lead wire may be weakened and cause a minute gap resulting in the deterioration of its resistance to moisture.

Sensitivity may also be changed by this stress.

4. Power supply line/power transmission line

If a power supply line/power transmission line becomes longer, noise and/or oscillation may be found on the line. In this case, set the capacitor of 0.1 μF to 10 μF near a Hall IC to prevent it.

If a voltage of 18 V or more is thought to be applied to the power supply line (flyback voltage from coil or the ignition pulse, etc.), avoid it with external components (capacitor, resistor, Zener diode, diode, surge absorbing elements, etc.).

5. V_{CC} and GND

Do not reverse V_{CC} and GND. If the V_{CC} and GND pins are reversely connected, this IC will be destroyed. If the IC GND-pin voltage is set higher than other pin voltage, the IC configuration will become same as a forward biased diode. Therefore, it will turn on at the diode forward voltage (approximately 0.7 V), and a large current will flow through the IC, ending up in its destruction. (This is common to Monolithic IC.)

6. Cautions on power ON of Hall IC

When a Hall IC is turned ON, the position of the magnet or looseness may change the output of a Hall IC, and a pulse may be generated. Therefore, care should be given whenever the output state of a Hall IC is critical when the supply power is ON.

■ Technical Data

- Position of a Hall element (unit in mm)

Distance from a package surface to sensor part: 0.71 mm

A Hall element is placed on the shaded part in the figure.

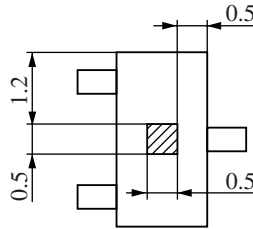

- Magneto-electro conversion characteristics

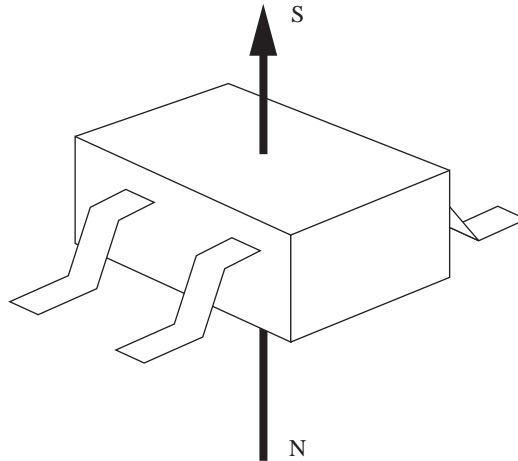

Direction of applied magnetic field

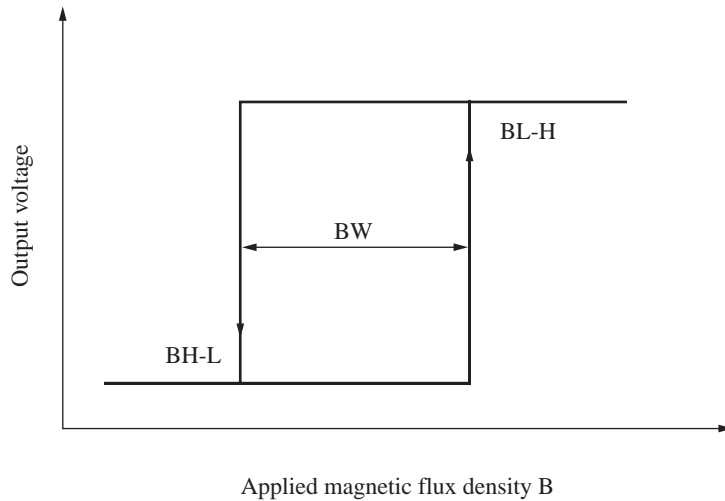

This datasheet has been download from:

www.datasheetcatalog.com

Datasheets for electronics components.