

Silicon Variable Capacitance Diode

Preliminary data

- For VHF TV-tuners
- High capacitance ratio
- Low series inductance
- Low series resistance
- Extremely small plastic SMD package
- Excellent uniformity and matching due to "in-line" matching assembly procedure

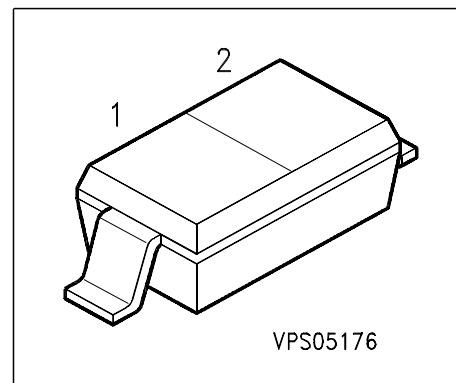

Type	Marking	Ordering Code	Pin Configuration	Package
BB 644	yellow 4	Q62702-B0905 group matched	1 = C	SOD-323
BB 644	yellow 4	Q62702-B0907 unmatched	2 = A	

Maximum Ratings

Parameter	Symbol	Value	Unit
Diode reverse voltage	V_R	30	V
Peak reverse voltage ($R \geq 5k\Omega$)	V_{RM}	35	
Forward current	I_F	20	mA
Operating temperature range	T_{op}	-55 ...+150	°C
Storage temperature	T_{stg}	-55 ...+150	

Electrical Characteristics at $T_A = 25^\circ\text{C}$, unless otherwise specified.

Parameter	Symbol	Values			Unit
		min.	typ.	max.	
DC characteristics					
Reverse current $V_R = 30\text{ V}$	I_R	-	-	10	nA
Reverse current $V_R = 30\text{ V}, T_A = 85^\circ\text{C}$	I_R	-	-	100	
AC characteristics					
Diode capacitance $V_R = 1\text{ V}, f = 1\text{ MHz}$ $V_R = 2\text{ V}, f = 1\text{ MHz}$ $V_R = 25\text{ V}, f = 1\text{ MHz}$ $V_R = 28\text{ V}, f = 1\text{ MHz}$	C_T	39 29.4 2.5 2.4	41.8 31.85 27 2.55	44.5 34.2 2.85 2.75	pF
Capacitance ratio $V_R = 2\text{ V}, V_R = 25\text{ V}, f = 1\text{ MHz}$	C_{T2}/C_{T25}	11	11.8	12.5	-
Capacitance ratio $V_R = 1\text{ V}, V_R = 28\text{ V}, f = 1\text{ MHz}$	C_{T1}/C_{T28}	15.2	16.4	17.5	
Capacitance ratio ¹⁾ $V_R = 1\text{ V}, V_R = 28\text{ V}, f = 1\text{ MHz}$	$\Delta C_T/C_T$	-	-	2	%
Series resistance $V_R = 1\text{ V}, f = 1\text{ GHz}$	r_s	-	0.6	0.75	Ω
Series inductance	L_s	-	1.8	-	nH

1) In-line matching. For details please refer to Application Note 047

Diode capacitance $C_T = f(V_R)$

$f = 1\text{MHz}$

