

STRUCTURE Silicon Monolithic Integrated Circuit

PRODUCT CMOS Type series regulator

TYPE **BH18LB1WHFV**

PACKAGE Fig.1 (Plastic Mold)

BLOCK Fig.2

TEST CIRCUIT Fig.3~8

APPRICATION CIRCUIT Fig.21

FUTURES

- Output Voltage Accuracy $1.8V \pm 25mV$
- Output Max Current 150mA
- Low Quiescence Current $40 \mu A$
- Stable With Ceramic Output Capacitor
- High Ripple Rejection Rate 70dB(f=1kHz)
- Over Current Protection
- Thermal Shutdown
- Output Control
- Package HVSOF5

ABSOLUTE MAXIMUM RATINGS (Ta=25°C)

PARAMETER	Symbol	Limit	Unit
Power Supply Voltage	VMAX	-0.3 ~ +6.5	V
Power Dissipation	Pd	410 *1	mW
Operating Temperature Range	Topr	-40 ~ +85	°C
Storage Temperature Range	Tstg	-55 ~ +125	°C

*1 Pd derated at $4.1mW/°C$ for temperature above $Ta=25°C$,
mounted on $70 \times 70 \times 1.6mm$ glass-epoxy PCB.

RECOMMENDED OPERATING CONDITIONS

PARAMETER	Symbol	Limit	Unit
Power Voltage	VIN	2.5~5.5	V
Output Max Current	IMAX	150	mA

●ELECTRICAL CHARACTERISTICS (Ta=25°C, VIN=3.5V, STBY=1.5V, Cin=0.1 μF, Co=1 μF)

PARAMETER	Symbol	Limit			UNIT	Conditions
		MIN.	TYP.	MAX.		
【REGULATOR】						
Output Voltage	VOUT	1.775	1.800	1.825	V	IOUT=1mA
Circuit Current	IGND	-	40	70	μA	IOUT=50mA
Circuit Current(STBY)	ISTBY	-	-	1.0	μA	STBY=0V
Ripple Rejection Ratio	RR	-	70	-	dB	VRR=-20dBv, fRR=1kHz, IOUT=10mA
Load Response 1	LTV1	-	50	-	mV	IOUT=1mA to 30mA
Load Response 2	LTV2	-	50	-	mV	IOUT=30mA to 1mA
Line Regulation	VDL1	-	2	20	mV	VIN=3.0V to 5.5V, IOUT=50mA
Load Regulation 1	VDL01	-	10	30	mV	IOUT=1mA to 100mA
Load Regulation 2	VDL02	-	15	90	mV	IOUT=1mA to 150mA
【OVER CURRENT PROTECTION】						
Limit Current	ILMAX	-	300	-	mA	VIN=3.5V, Vo=VOUT×0.97
Short Current	ISHORT	-	110	-	mA	VIN=3.5V, Vo=0V
【STBY】						
STBY Pull-down Resistor	RSTB	550	1100	2200	kΩ	
STBY Control Voltage	ON	VSTBH	1.5	-	VCC	V
	OFF	VSTBL	-0.3	-	0.3	V

●This product is not designed for protection against radio active rays.

●RECOMMENDED OPERATING CONDITION

PARAMETER	Symbol	MIN	TYP	MAX	UNIT	CONDITION
Input Capacitor	Cin	0.1	-	-	μF	Ceramic capacitor recommended
Output Capacitor	Co	1.0	-	-	μF	Ceramic capacitor recommended

○ PACKEGE (Plastic Mold)

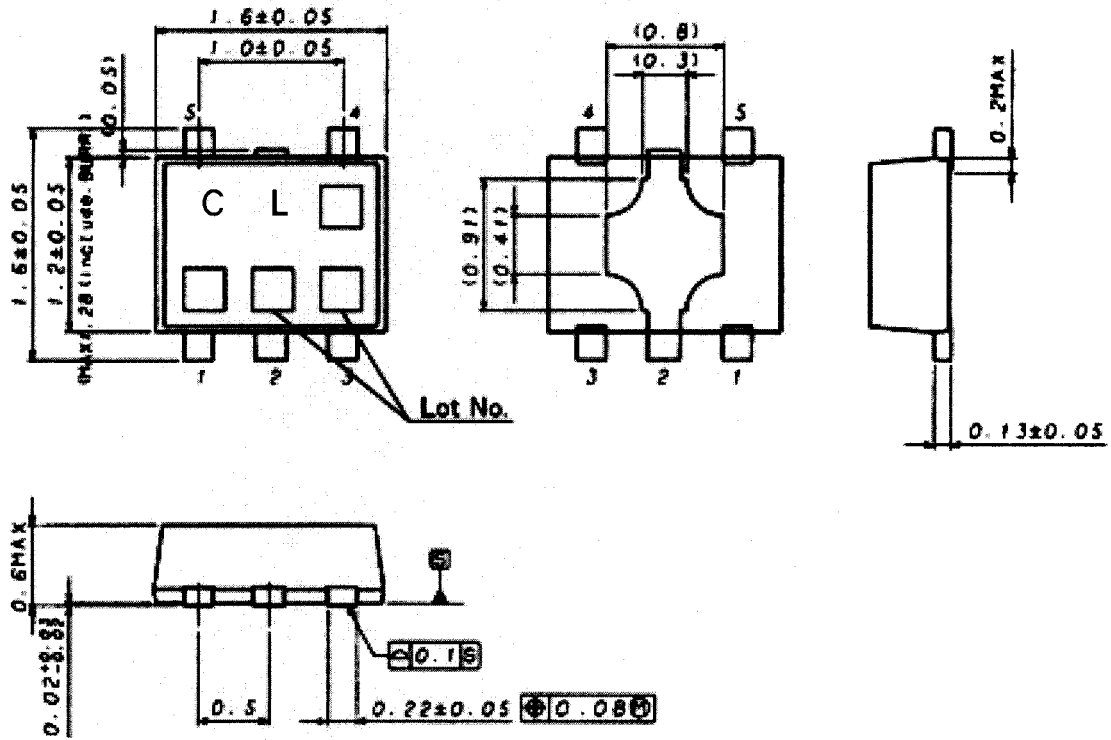

(UNIT: mm)

Drawing No. EX108-5002

○BLOCK DIAGRAM

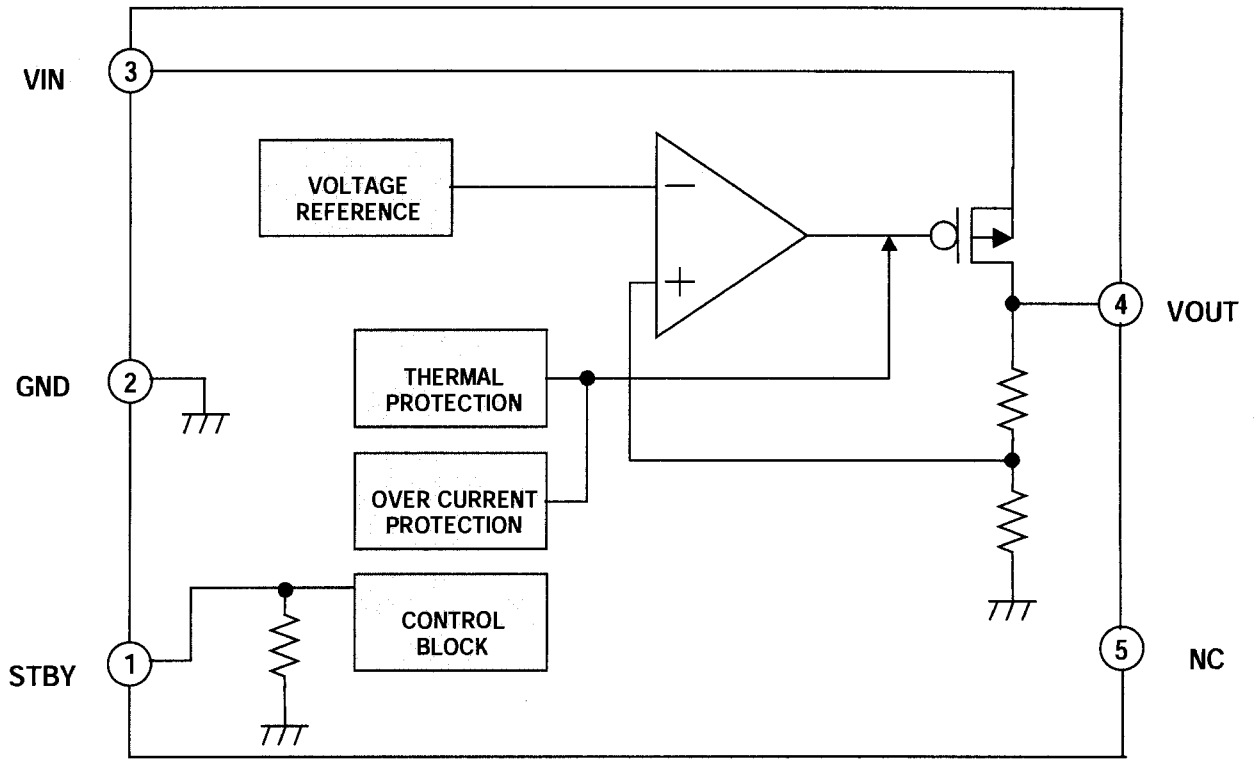

Fig.2 BLOCK DIAGRAM

○PIN DESCRIPTION

PIN No.	PIN Name	DESCRIPTION
1	STBY	OUTPUT CONTROL (High:ON, Low:OFF)
2	GND	GROUND Pin
3	VIN	INPUT Pin
4	VOUT	OUTPUT Pin
5	NC	NO CONNECT PIN

○TEST CIRCUIT

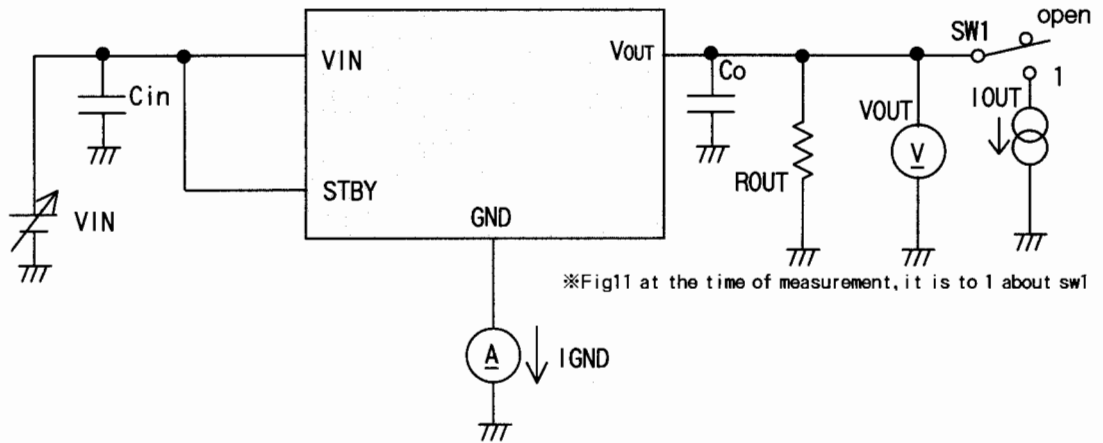

Fig.3 GND Current · Output Voltage Test Circuit (Characteristic example:Fig.9~11,19,20)

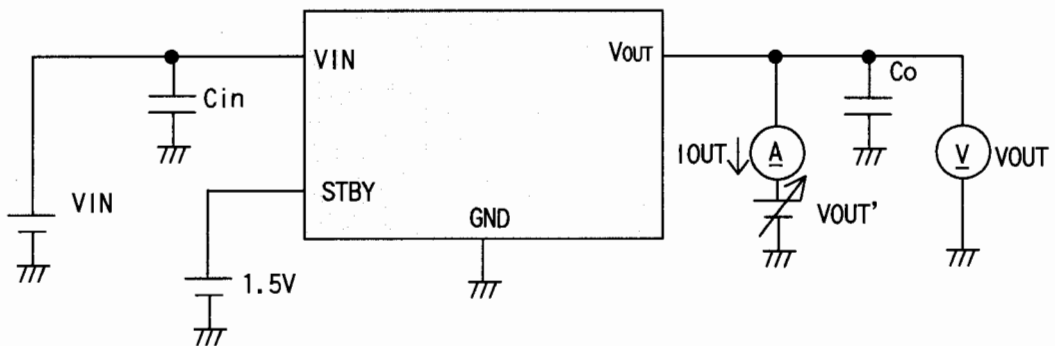

Fig.4 Over Current Protection Test Circuit(Characteristic example:Fig.12)

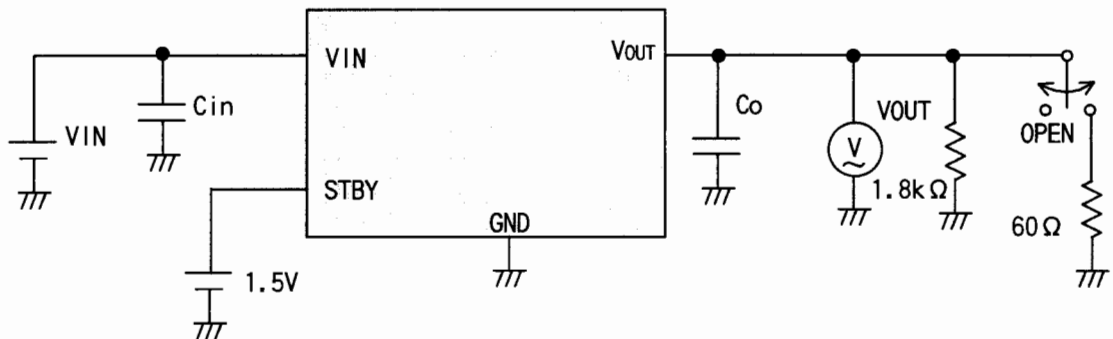

Fig.5 Load Transient response (Characteristic example :Fig.13~15)

○ TEST CIRCUIT

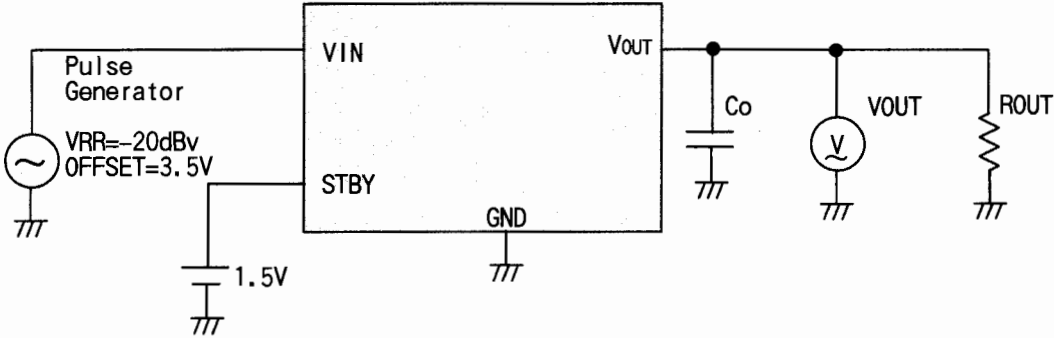

Fig.6 Ripple Rejection Ratio Test Circuit (Characteristic example:Fig.16)

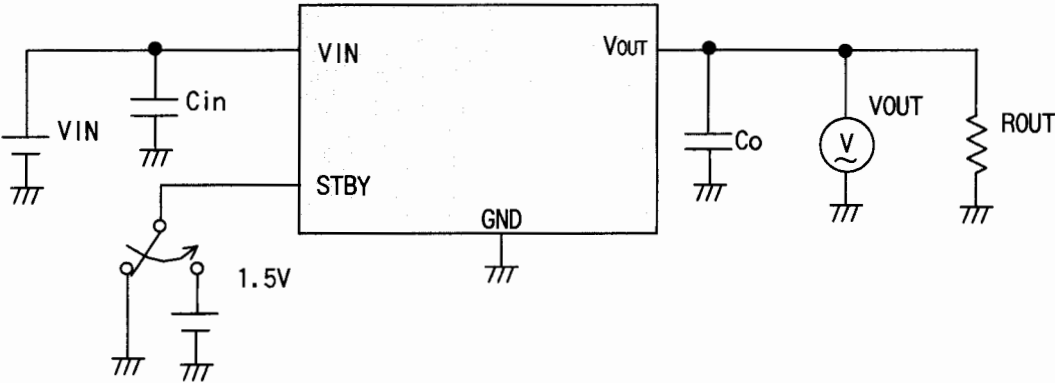

Fig.7 Output Voltage start-up time Test Circuit (Characteristic example:Fig.17)

○ TEST CIRCUIT

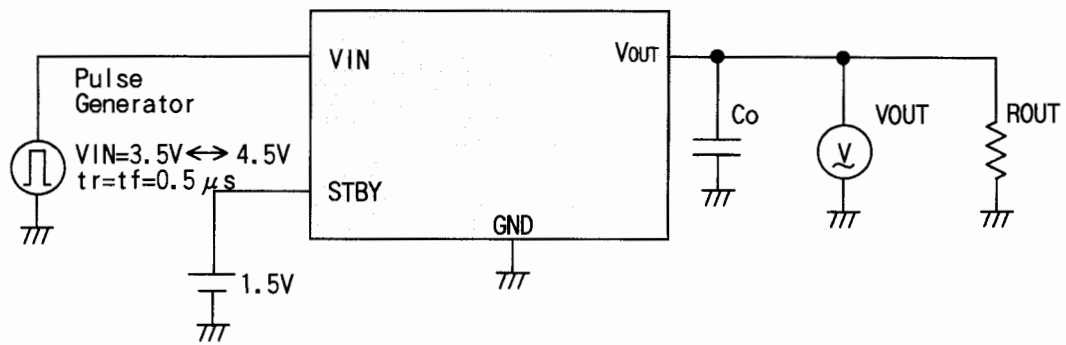

Fig.8 Line Transient response test circuit (Characteristic example : Fig.18)

○DC Characteristic example(Reference: Package is SSOP5.)

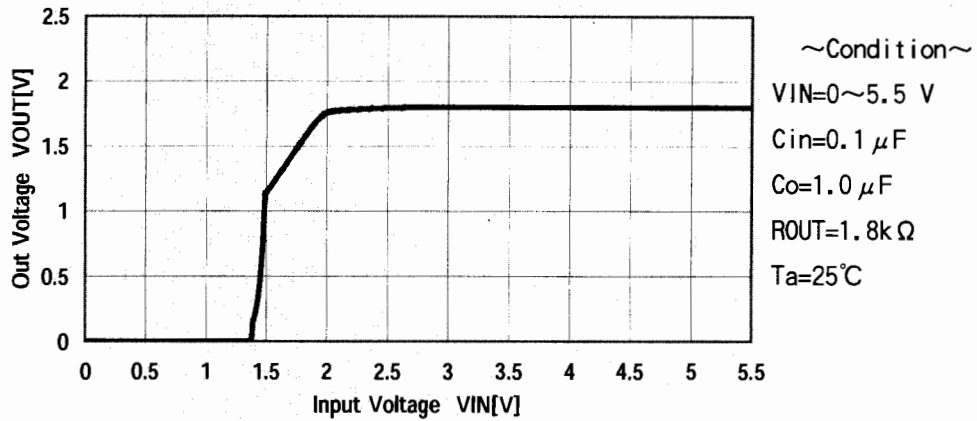

Fig.9 Output Voltage-Input Voltage

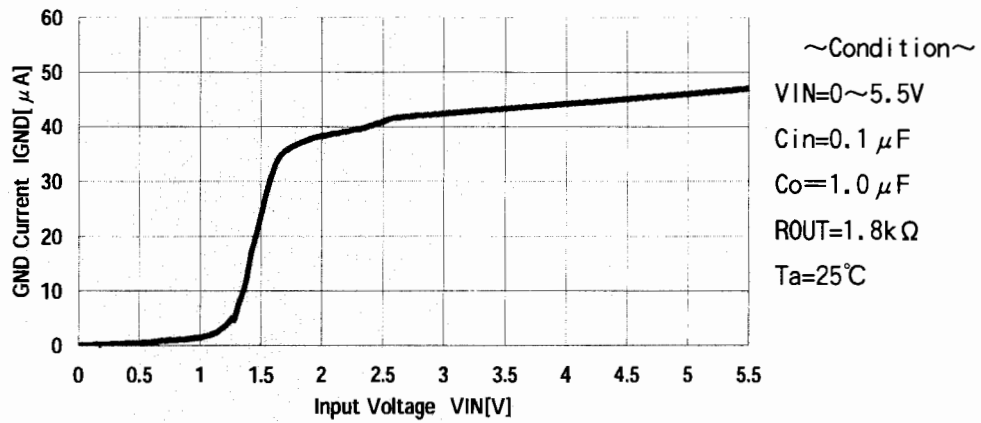

Fig.10 GND Current-Input Voltage

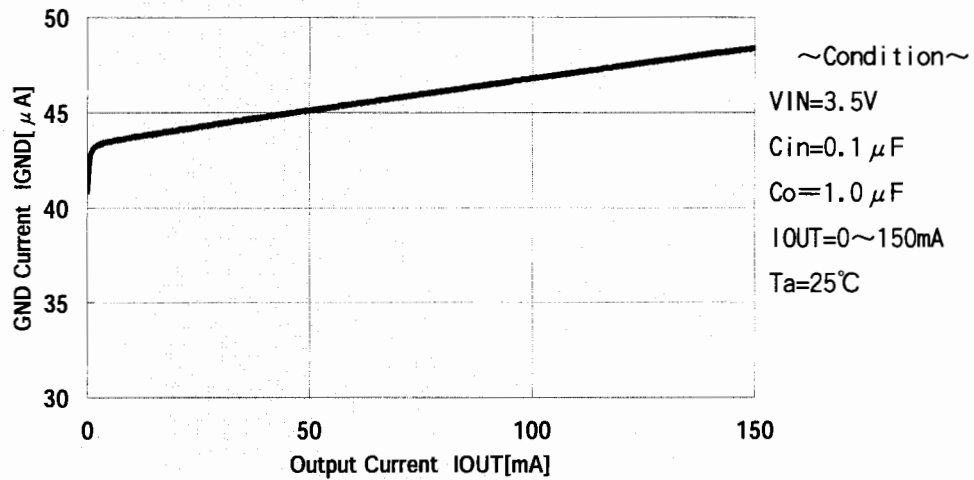

Fig.11 GND Current-Output Current

○DC Characteristic example (Reference: Package is SSOP5.)

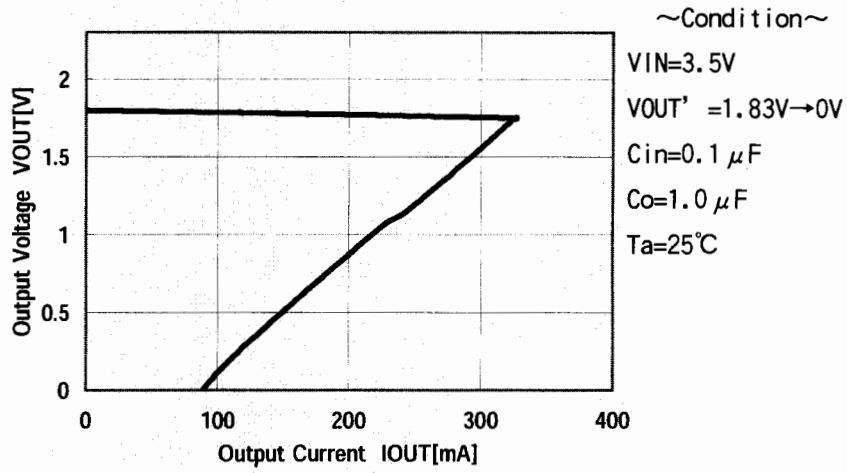

Fig.12 Output Voltage-Output Current

○AC Characteristic example(Reference: Package is SSOP5.)

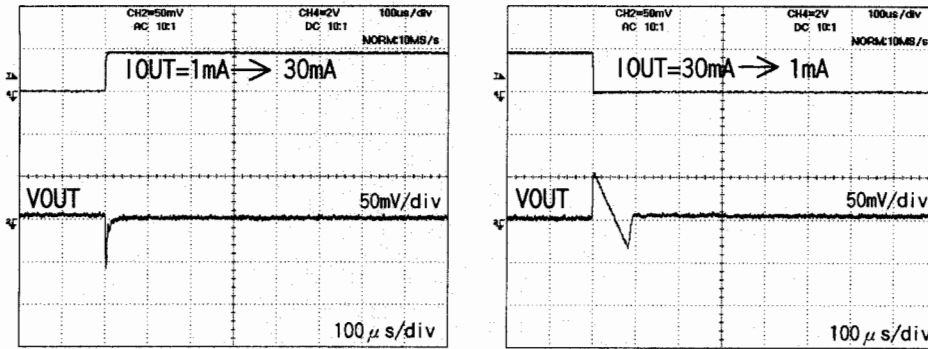

Fig.13 Load Transient response (Co=1.0 μF)

~Condition~
 VIN=3.5V
 Cin=0.1 μF
 Co=1.0 μF
 IOU=1mA ↔ 30mA
 Ta=25°C

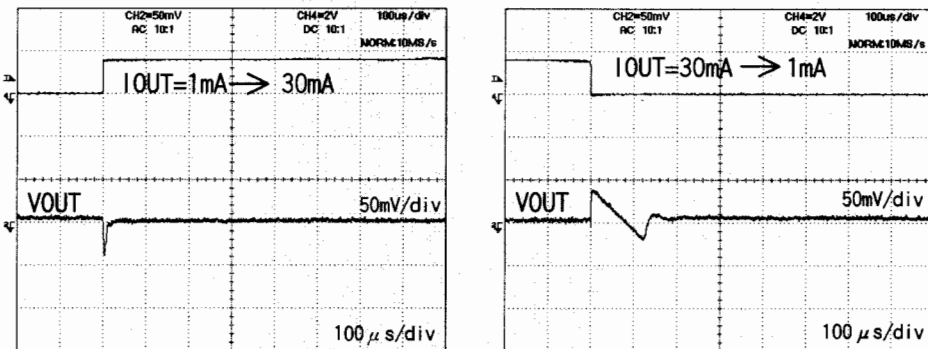

Fig.14 Load Transient response (Co=2.2 μF)

~Condition~
 VIN=3.5V
 Cin=0.1 μF
 Co=2.2 μF
 IOU=1mA ↔ 30mA
 Ta=25°C

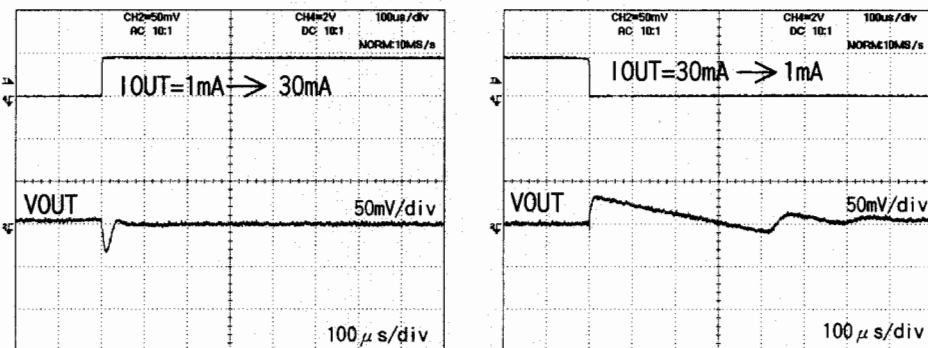

Fig.15 Load Transient response (Co=10 μF)

~Condition~
 VIN=3.5V
 Cin=0.1 μF
 Co=10 μF
 IOU=1mA ↔ 30mA
 Ta=25°C

○AC Characteristic example(Reference package is SSOP5.)

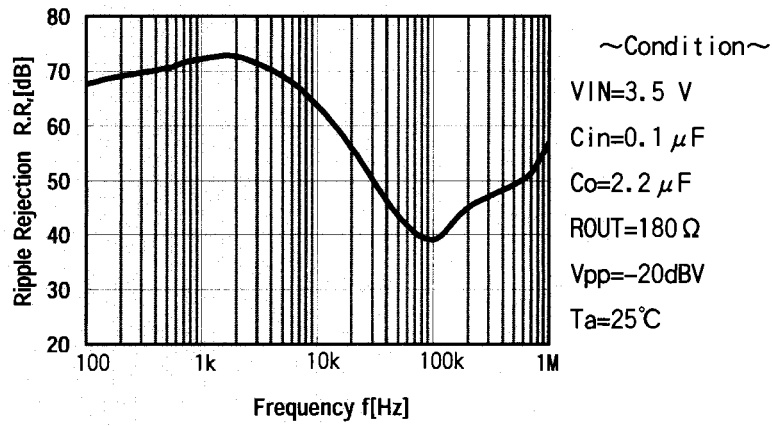

Fig.16 Ripple Rejection - Frequency

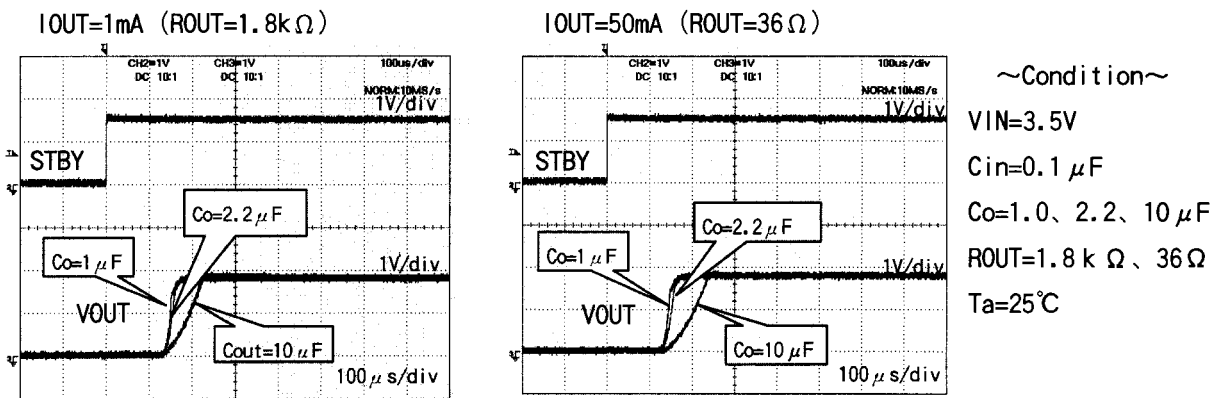

Fig.17 Output Voltage Start-up time

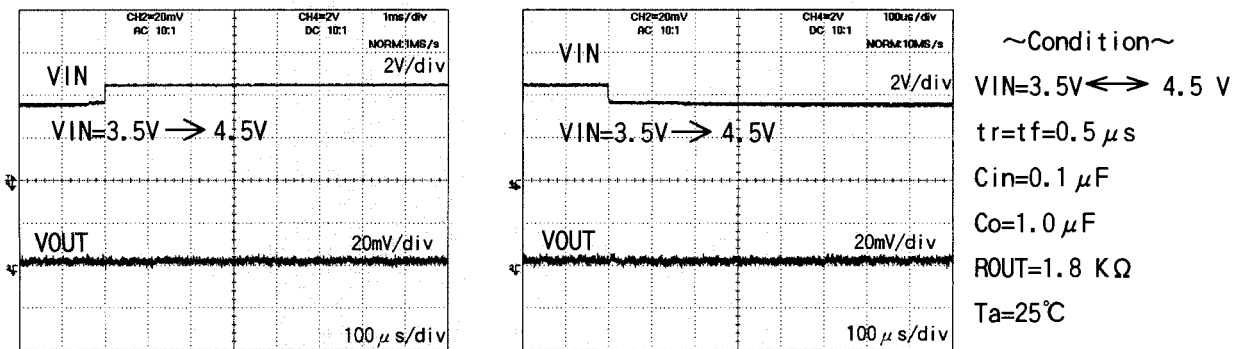

Fig.18 Line Transient response

○ Temperature Characteristic example(Reference: package is SSOP5.)

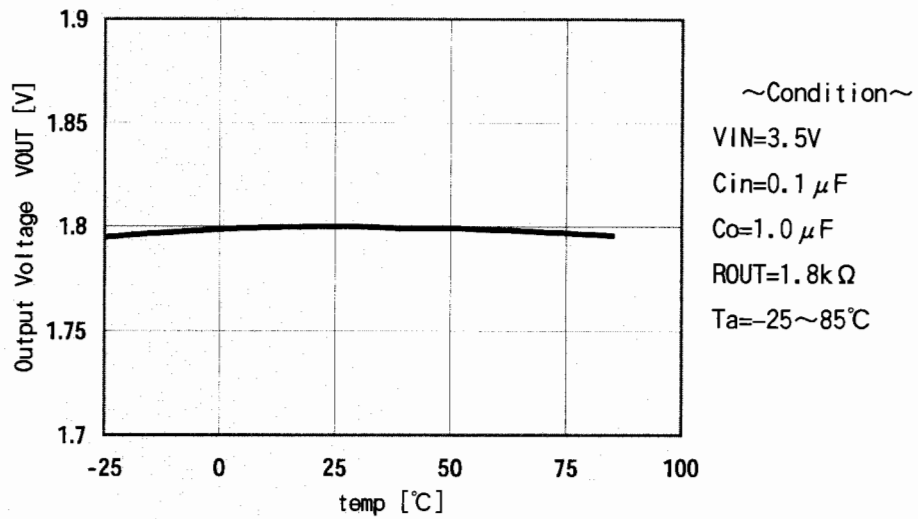

Fig.19 Output Voltage- Temperature

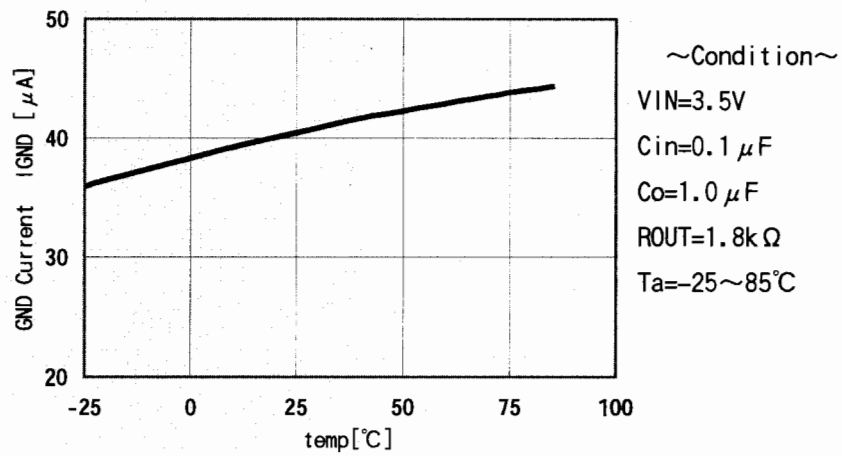

Fig.20 GND Current- Temperature

○ Application Circuit

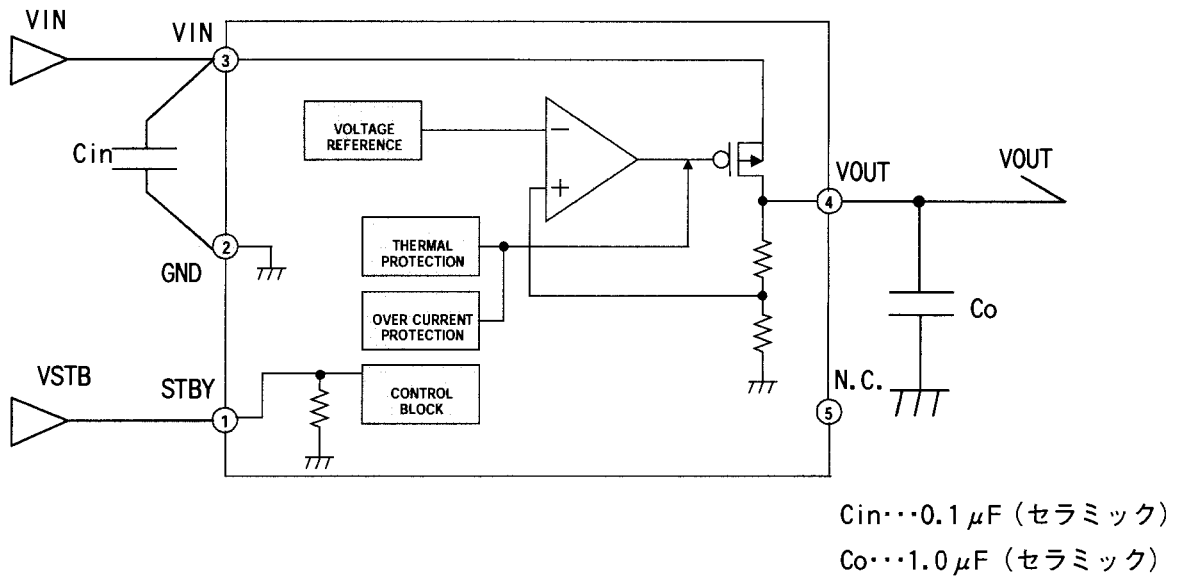

Fig.21 Application Circuit (Reference)

※ Note

The above application circuit is recommended for use. Make sure to confirm the adequacy of characteristics. When using the application circuit make sure to leave an adequate margin for external components, while considering static and transitional characteristics, as well as dispersion of the IC.

○Operation Notes

1.) Absolute maximum ratings

This product is produced with strict quality control, however, may be destroyed if operated beyond its absolute maximum ratings.

If the device is destroyed by exceeding the recommended maximum ratings, the failure mode will be difficult to determine. (E.g. short mode, open mode)

Therefore, physical protection counter-measures (like fuse) should be implemented when operating conditions are beyond the absolute maximum ratings specified.

2.) GND potential

GND potential must be the lowest potential no matter what may happen. Actually, including transitional states, all pins except GND must not be the voltage below GND.

3.) Setting of heat

Consider Pd of actually using states, carry out the heat design which have adequate margin.

4.) Pin short and mistake fitting

When mounting the IC on the PCB, pay attention to the orientation of the IC. If there is a placement mistake, the IC may burn up.

5.) Actions in strong magnetic field

Using the IC within a strong magnetic field may cause a malfunction.

6.) Mutual impedance

Use short and wide wiring tracks for the power supply and ground to keep the mutual impedance as small as possible. Use a capacitor to keep ripple to a minimum.

7.) Voltage of STB pin

For standby mode set STB voltage below 0.3V. For normal operation set beyond 1.5V. The region Between 0.3V and 1.5V is not recommended and may cause improper operation.

8.) Over current protection circuit

Over current and short circuit protection is built-in at the output, and IC destruction is prevented at the time of load short circuit. These protection circuit is effective in the destructive prevention by the sudden accident, please avoid use to which a protection circuit operates continuously.

9.) Thermal shut-down

In cases of operation at high temperature thermal shut-down will be activated and output will be turned off. Once IC returns to its normal operating temperature, output will be turned back on.

○ Operation Notes

10.) Output capacitor

To prevent oscillation at the output, it is recommended that the IC be operated at the stable region shown in Fig.22. It operates at the capacitance of more than $1.0\mu\text{F}$. As capacitance is larger, stability becomes more stable and characteristic of output load fluctuation is also improved.

$C_{out}=1.0\mu\text{F}$ Temp= -25°C

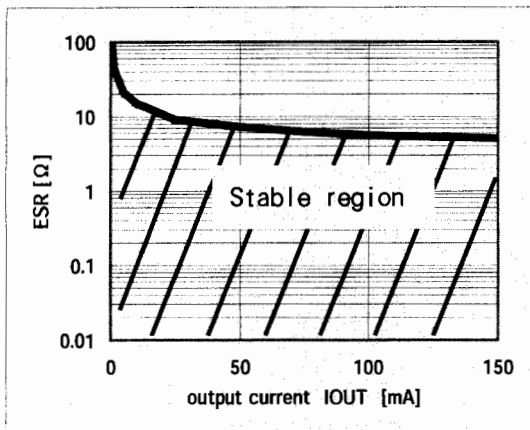

$C_{out}=2.2\mu\text{F}$ Temp= -25°C

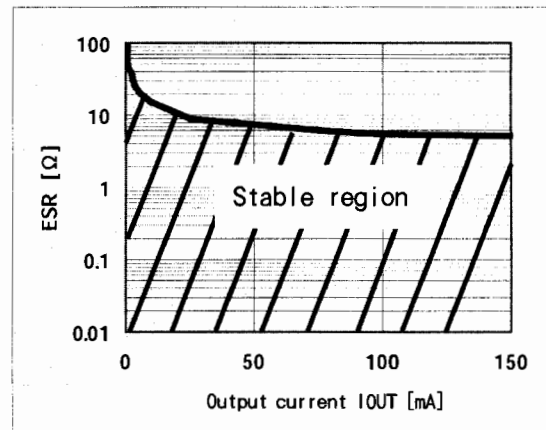

$C_{out}=1.0\mu\text{F}$ Temp= $+25^{\circ}\text{C}$

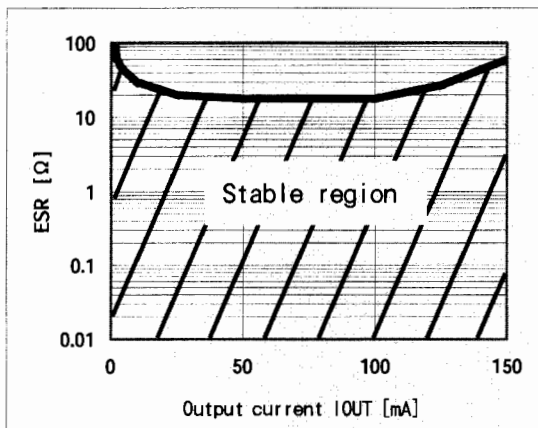

$C_{out}=2.2\mu\text{F}$ Temp= $+25^{\circ}\text{C}$

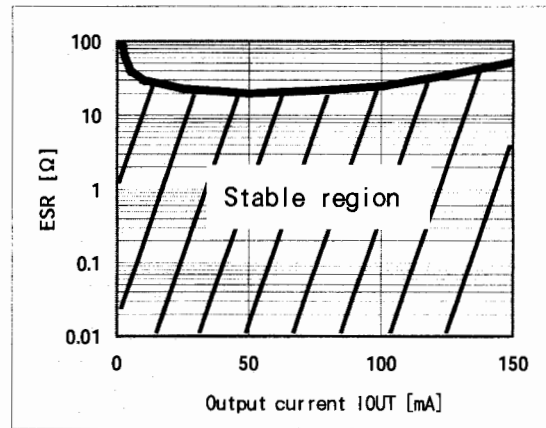

Fig.22 Stable region characteristic
(Reference)

○ Operation Notes

11.) Input capacitor

It is recommended that a 0.1 μF bypass capacitor be placed between VIN and GND. Consider mounting of the capacitor such that lead lengths are as short as possible. Ceramic capacitors, in general, exhibit the best characteristics for stability against changing temperature and increasing DC bias voltage. Specifically, ceramic capacitors that are B type and have a high voltage rating exhibit the best characteristic. (See Figures below for reference.)

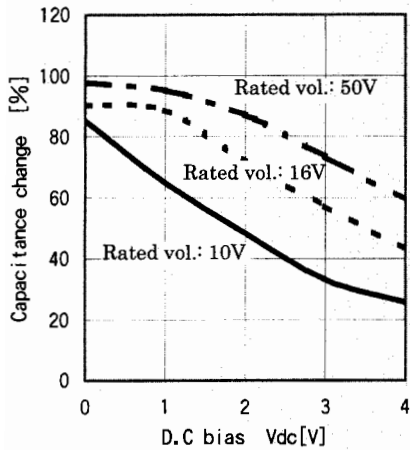

Fig. 23 Capacitance change-Bias characteristic (F type) (Reference)

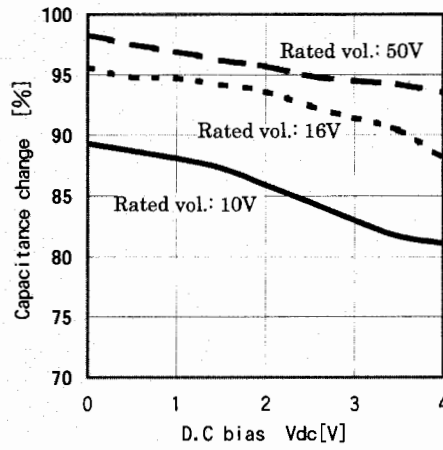

Fig. 24 Capacitance change-Bias characteristic (B type) (Reference)

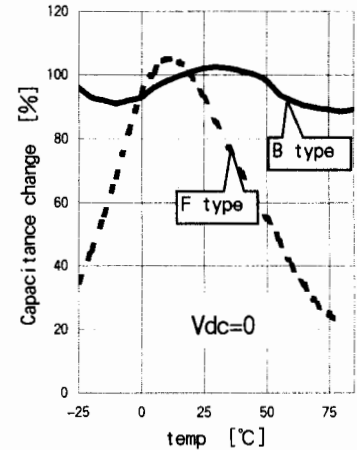

Fig. 25 Capacitance change-Bias characteristic (F type, B type) (Reference)

○ Operation Notes

12.) Regarding input pin of the IC

This is a monolithic IC which has a P+ substrate and a P isolation between each pin. A P-N junction is formed from this P layer at each pin.

For example the relation between each potential is as follows,

(When $GND > PinB$ and $GND > PinA$, the P-N junction operates as a parasitic diode.)

(When $PinB > GND > PinA$, the P-N junction operates as a parasitic transistor.)

Parasitic diodes can occur inevitably in the IC structure. The operation of parasitic diodes can result in mutual interference among circuits as well as operation faults and physical damage. Accordingly, you must not use methods by which parasitic diodes operate, such as applying a voltage that is lower than the GND (P substrate) voltage to an input pin.

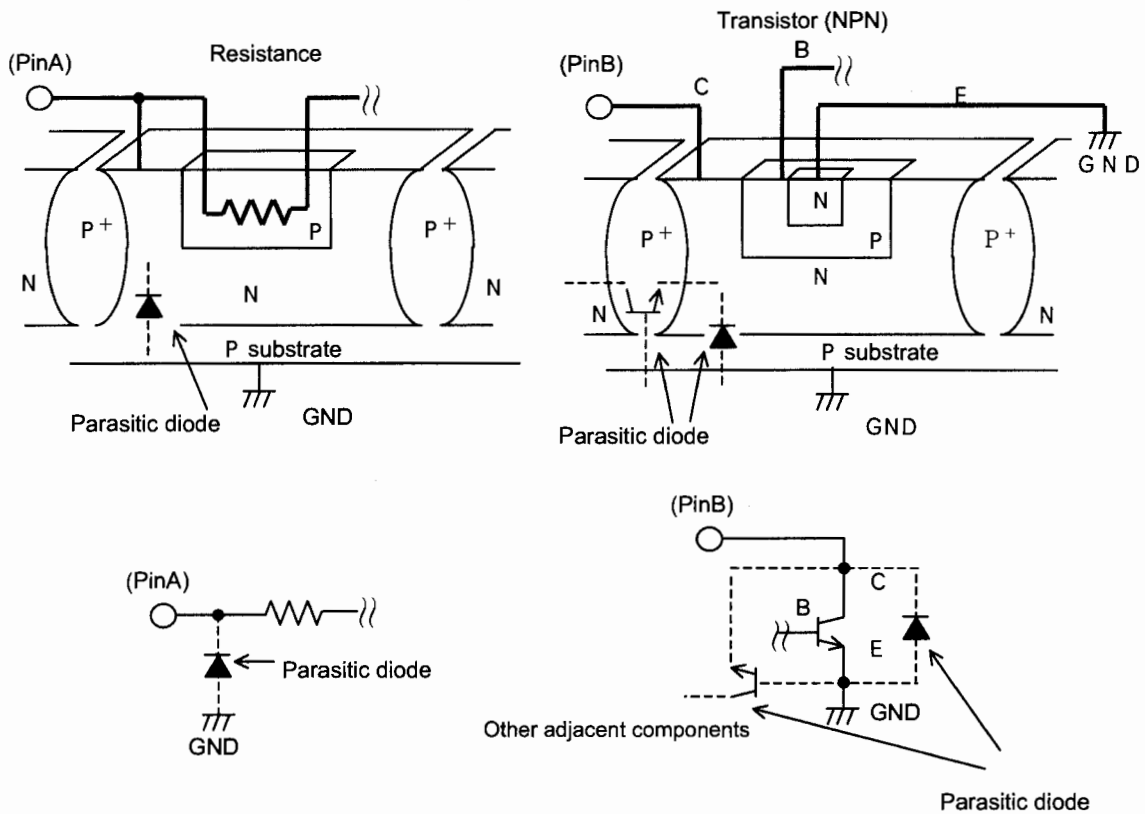

Fig.26 Simplified structure of a Monolithic IC

Notes

- No technical content pages of this document may be reproduced in any form or transmitted by any means without prior permission of ROHM CO.,LTD.
- The contents described herein are subject to change without notice. The specifications for the product described in this document are for reference only. Upon actual use, therefore, please request that specifications to be separately delivered.
- Application circuit diagrams and circuit constants contained herein are shown as examples of standard use and operation. Please pay careful attention to the peripheral conditions when designing circuits and deciding upon circuit constants in the set.
- Any data, including, but not limited to application circuit diagrams information, described herein are intended only as illustrations of such devices and not as the specifications for such devices. ROHM CO.,LTD. disclaims any warranty that any use of such devices shall be free from infringement of any third party's intellectual property rights or other proprietary rights, and further, assumes no liability of whatsoever nature in the event of any such infringement, or arising from or connected with or related to the use of such devices.
- Upon the sale of any such devices, other than for buyer's right to use such devices itself, resell or otherwise dispose of the same, no express or implied right or license to practice or commercially exploit any intellectual property rights or other proprietary rights owned or controlled by
- ROHM CO., LTD. is granted to any such buyer.
- Products listed in this document are no antiradiation design.

The products listed in this document are designed to be used with ordinary electronic equipment or devices (such as audio visual equipment, office-automation equipment, communications devices, electrical appliances and electronic toys).

Should you intend to use these products with equipment or devices which require an extremely high level of reliability and the malfunction of which would directly endanger human life (such as medical instruments, transportation equipment, aerospace machinery, nuclear-reactor controllers, fuel controllers and other safety devices), please be sure to consult with our sales representative in advance.

About Export Control Order in Japan

Products described herein are the objects of controlled goods in Annex 1 (Item 16) of Export Trade Control Order in Japan.

In case of export from Japan, please confirm if it applies to "objective" criteria or an "informed" (by MITI clause) on the basis of "catch all controls for Non-Proliferation of Weapons of Mass Destruction.