

---

## LOW NOISE Dual 300mA LDO

---

NO. EA-131-070724

### OUTLINE

The RP150K Series are CMOS-based dual voltage regulator ICs with high output voltage accuracy, low supply current, low dropout, and high ripple rejection. Each of these voltage regulator ICs consists of a voltage reference unit, an error amplifier, resistors for setting Output Voltage, a current limit circuit, and a chip enable circuit.

These ICs perform with low dropout voltage due to built-in transistor with low ON resistance, and a chip enable function prolongs the battery life of each system. The line transient response and load transient response of the RP150 Series are excellent, thus these ICs are very suitable for the power supply for hand-held communication equipment.

The output voltage of these ICs is internally fixed with high accuracy (1%). Since the packages for these ICs are PLP2020-8 package, 2ch LDO regulators are included in each packages, high density mounting of the ICs on boards is possible.

### FEATURES

- Supply Current ..... Typ. 24 $\mu$ A $\times$ 2 (VR1&VR2)
- Standby Current ..... Typ. 0.1 $\mu$ A
- Dropout Voltage..... Typ. 0.21V ( $I_{OUT}$ =300mA,  $V_{OUT}$ =2.8V)  
Typ. 0.24V ( $I_{OUT}$ =300mA,  $V_{OUT}$ =2.5V)
- Ripple Rejection ..... Typ. 80dB (f=1kHz)
- Temperature-Drift Coefficient of Output Voltage ..... Typ.  $\pm$ 30ppm/ $^{\circ}$ C
- Line Regulation ..... Typ. 0.02%/V
- Output Voltage Accuracy .....  $\pm$ 1.0%
- Input Voltage Range..... 2.5V to 5.25V
- Output Voltage Range..... 1.5V to 3.3V
- Package ..... PLP2020-8
- Built-in Fold Back Protection Circuit..... Typ. 50mA
- Built-in Auto Discharge Function ..... B Version
- Ceramic capacitors are recommended to be used with this IC ....  $C_{IN}$ = $C_{OUT}$ =1.0 $\mu$ F or more

### APPLICATIONS

- Power source for portable communication equipment.
- Power source for electrical appliances such as cameras, VCRs and camcorders.
- Power source for battery-powered equipment.

BLOCK DIAGRAMS

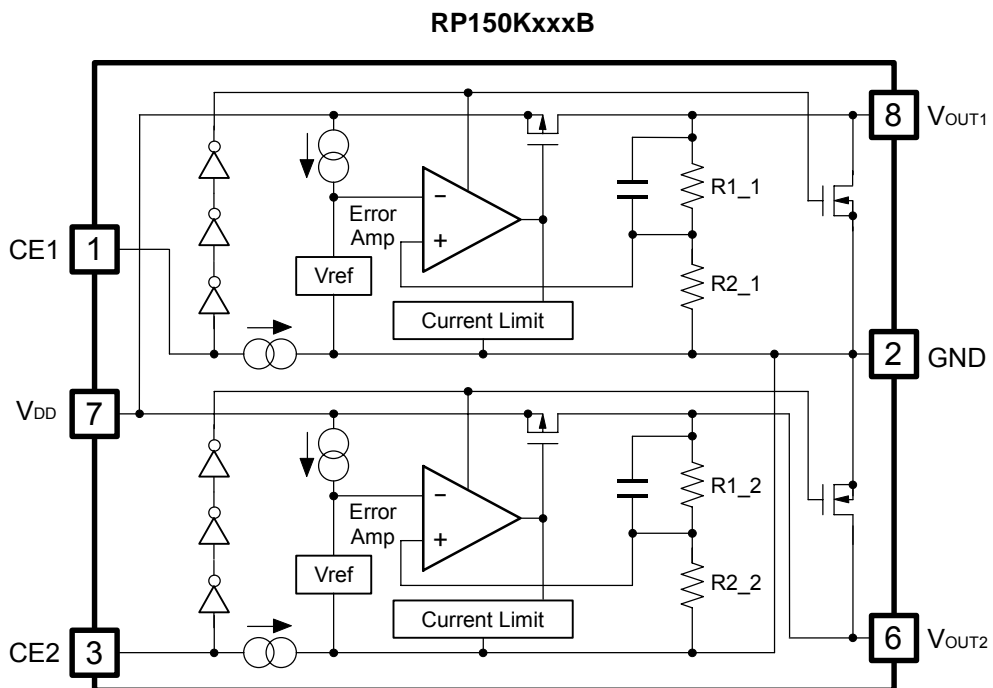
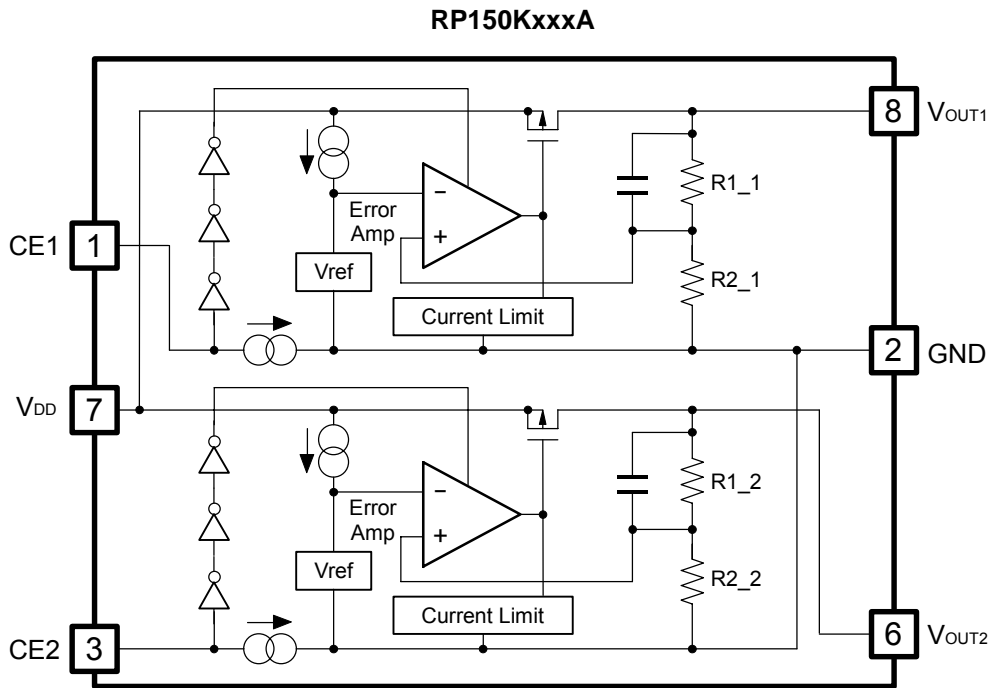

## SELECTION GUIDE

The output voltage, auto discharge function\*, and the taping type for the ICs can be selected at the user's request.

The selection can be made with designating the part number as shown below;

RP150Kxxxx-xx-X ←Part Number  
 ↑ ↑ ↑ ↑ ↑  
 a b c d e

Code	Contents
a	Designation of Package Type: K: PLP2020-8
b	Setting combination of 2ch Output Voltage ( $V_{OUT}$ ): Serial Number for Voltage setting from 001, Stepwise setting in the range of 1.5V to 3.3V is possible for each channel.
c	Designation of Mask Option: A: without auto discharge function* at OFF state. B: with auto discharge function* at OFF state
d	Designation of Taping Type: Ex. TR (refer to Taping Specifications; TR type is the standard direction.)
e	Designation of composition of plating: None : Au plating

\*) When the mode is into standby with CE signal, auto discharge transistor turns on, and it makes the turn-off speed faster than normal type.

## PIN CONFIGURATIONS

● PLP2020-8

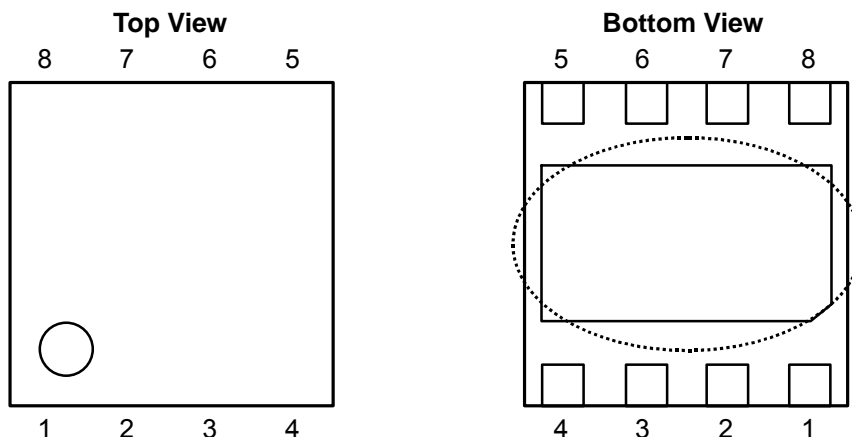

## PIN DESCRIPTIONS

● RP150K

Pin No.	Symbol	Description
1	CE1	Chip Enable Pin 1 ("H" Active)
2	GND	Ground Pin
3	CE2	Chip Enable Pin 2 ("H" Active)
4	NC	No Connection
5	NC	No Connection
6	V <sub>OUT2</sub>	Output Pin 2
7	V <sub>DD</sub>	Input Pin
8	V <sub>OUT1</sub>	Output Pin 1

\* Tab in the  parts have GND level. (They are connected to the back side of this IC.)  
Do not connect to other wires or land patterns.

## ABSOLUTE MAXIMUM RATINGS

Symbol	Item	Rating	Unit
V <sub>IN</sub>	Input Voltage	6.0	V
V <sub>CE</sub>	Input Voltage (CE Pin)	6.0	V
V <sub>OUT</sub>	Output Voltage	-0.3 to V <sub>IN</sub> +0.3	V
I <sub>OUT1</sub>	Output Current 1	400	mA
I <sub>OUT2</sub>	Output Current 2	400	mA
P <sub>D</sub>	Power Dissipation (PLP2020-8)**1	880	mW
Topt	Operating Temperature Range	-40 to 85	°C
Tstg	Storage Temperature Range	-55 to 125	°C

\*1) For Power Dissipation, please refer to PACKAGE INFORMATION to be described.

## ELECTRICAL CHARACTERISTICS

### • RP150KxxxA/B

$V_{IN}$ =Set  $V_{OUT}+1V$  for higher output of the regulator pair,

$I_{OUT}=1mA$ ,  $C_{IN}=C_{OUT}=1\mu F$ , unless otherwise noted.

$T_{opt}=25^{\circ}C$

Symbol	Item	Conditions	Min.	Typ.	Max.	Unit	
$V_{OUT}$	Output Voltage	$V_{IN}=\text{Set } V_{OUT}+1V$ $I_{OUT}=1mA$	$V_{OUT} > 2.0V$	$\times 0.99$		$\times 1.01$	V
			$V_{OUT} \leq 2.0V$	-20		+20	mV
$I_{OUT}$	Output Current		300			mA	
$\frac{\Delta V_{OUT}}{\Delta I_{OUT}}$	Load Regulation	$1mA \leq I_{OUT} \leq 200mA$		20	40	mV	
$V_{DIF}$	Dropout Voltage	$I_{OUT}=300mA$	$1.5V \leq \text{Set } V_{OUT} < 1.7V$		0.40	1.00	V
			$1.7V \leq \text{Set } V_{OUT} < 2.0V$		0.34	0.80	
			$2.0V \leq \text{Set } V_{OUT} < 2.5V$		0.29	0.50	
			$2.5V \leq \text{Set } V_{OUT} < 2.8V$		0.24	0.38	
			$2.8V \leq \text{Set } V_{OUT} \leq 3.3V$		0.21	0.34	
$I_{SS}$	Supply Current	$V_{OUT1}=V_{OUT2}=0V$		48	65	$\mu A$	
$I_{standby}$	Standby Current	$V_{CE}=0V$		0.1	3.0	$\mu A$	
$\frac{\Delta V_{OUT}}{\Delta V_{IN}}$	Line Regulation	Set $V_{OUT}+0.5V \leq V_{IN} \leq 5.0V$ (In case that $V_{OUT} \leq 2.0V$ , $2.5V \leq V_{IN} \leq 5.0V$ )		0.02	0.10	%/V	
RR	Ripple Rejection	$f=1kHz$ , Ripple 0.2Vp-p $V_{IN}=\text{Set } V_{OUT}+1V$ , $I_{OUT}=30mA$ (In case that $V_{OUT} \leq 2.0V$ , $V_{IN}=3V$ )		80		dB	
$V_{IN}$	Input Voltage	(*1)	2.5		5.25	V	
$\frac{\Delta V_{OUT}}{\Delta T_{opt}}$	Output Voltage Temperature Coefficient	$-40^{\circ}C \leq T_{opt} \leq 85^{\circ}C$		$\pm 30$		ppm/ $^{\circ}C$	
$I_{lim}$	Short Current Limit	$V_{OUT}=0V$		50		mA	
$I_{PD}$	CE Pull-down Current		0.05	0.3	0.6	$\mu A$	
$V_{CEH}$	CE Input Voltage "H"		1.5		6.0	V	
$V_{CEL}$	CE Input Voltage "L"				0.3	V	
en	Output Noise	BW=10Hz to 100kHz		30		$\mu V_{rms}$	
$R_{LOW}$	Low Output Nch Tr. ON Resistance (of B version)	$V_{IN}=4.0V$ $V_{CE}=0V$		30		$\Omega$	

\*1) Max. Input Voltage is 5.5V during 500hours

## TECHNICAL NOTES

When using these ICs, consider the following points:

### PCB Layout

Make  $V_{DD}$  and GND lines sufficient. If their impedance is high, noise pickup or unstable operation may result. Connect a capacitor with a capacitance value as much as  $1.0\mu\text{F}$  or more as C1 between  $V_{DD}$  and GND pin, and as close as possible to the pins.

Set the output capacitors C2 and C3 for phase compensation, as close as possible to the ICs, and make wiring as short as possible.

### Phase Compensation

In these ICs, phase compensation is made for securing stable operation even if the load current is varied.

For this purpose, connect capacitors with a capacitance value as much as  $1.0\mu\text{F}$  or more as C2 and C3 with good frequency characteristics and ESR (Equivalent Series Resistance) between  $V_{OUT}$  and GND pin, and as close as possible to the pins.

If you use a tantalum type capacitor and ESR value of the capacitor is large, output might be unstable. Evaluate your circuit with considering frequency characteristics.

Depending on the capacitor size, manufacturer, and part number, the bias characteristics and temperature characteristics are different. Evaluate the circuit with actual using capacitors.

## TYPICAL APPLICATIONS

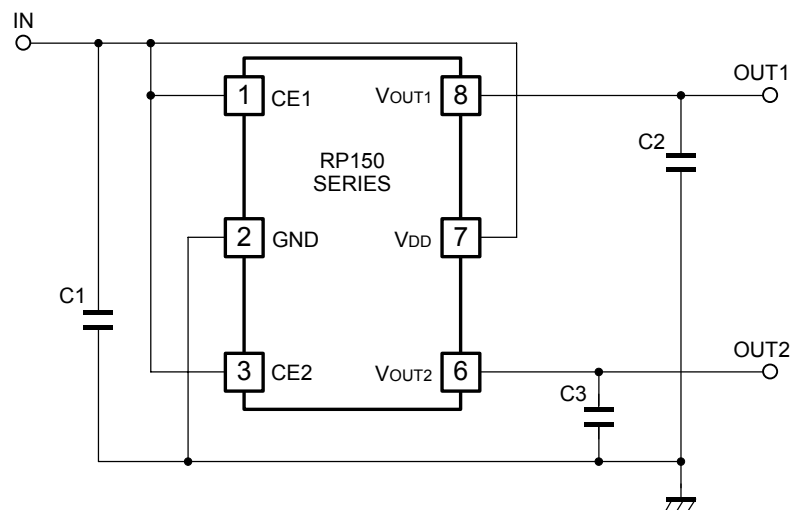

### (External Components)

Output Capacitor; Ceramic Type	C1, C2, C3
$1.0\mu\text{F}$	Kyocera CM05X5R105KD6AB
	TDK C1005JB0J105K
	Murata GRM155B31A105KE15

TEST CIRCUITS

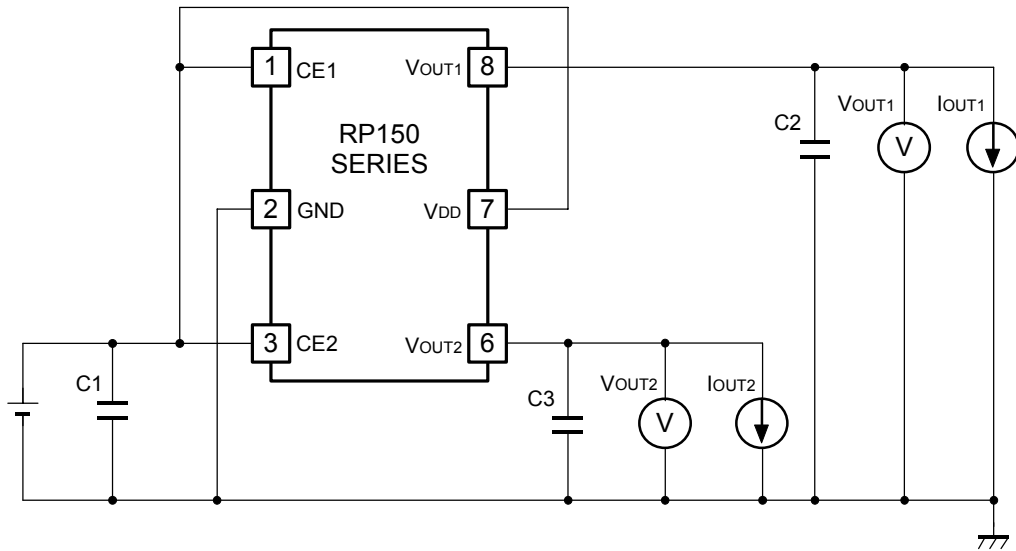

Standard test Circuit

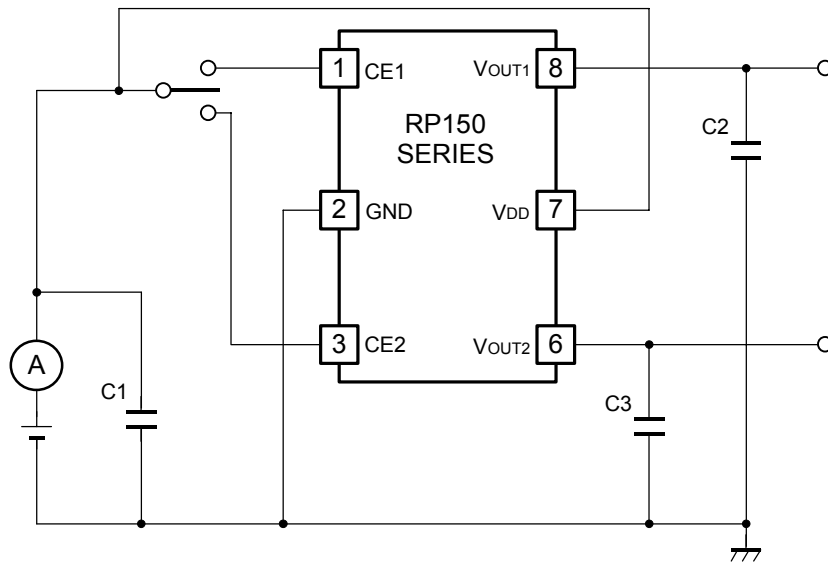

Supply Current Test Circuit

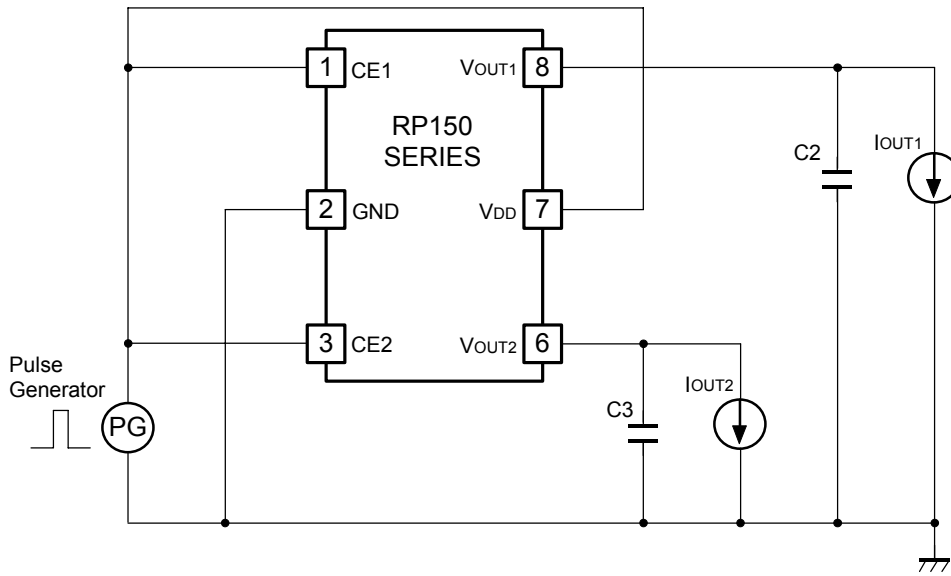

Test Circuit for Ripple Rejection

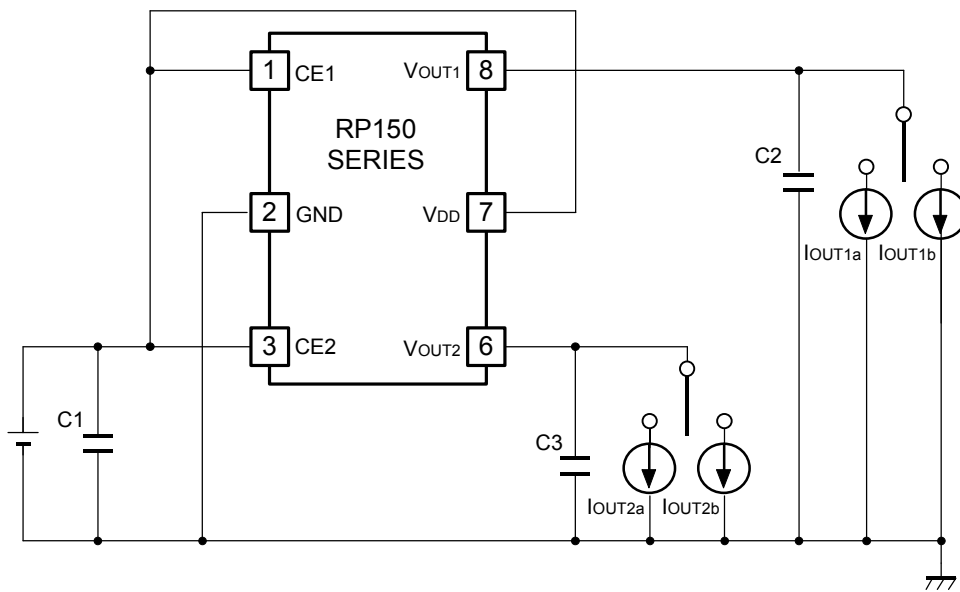

Test Circuit for Load Transient Response



## TYPICAL CHARACTERISTICS

### 1) Output Voltage vs. Output Current (Topt=25°C)

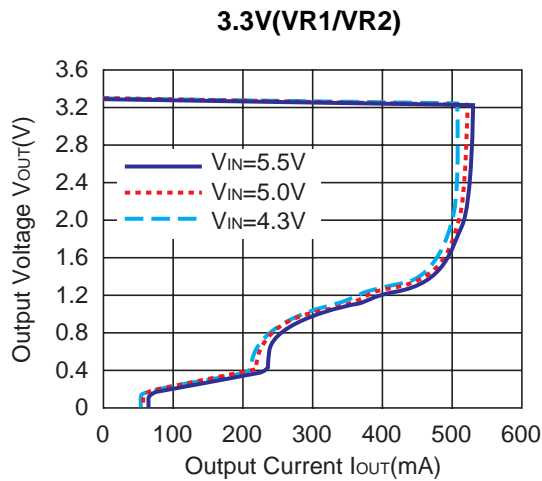
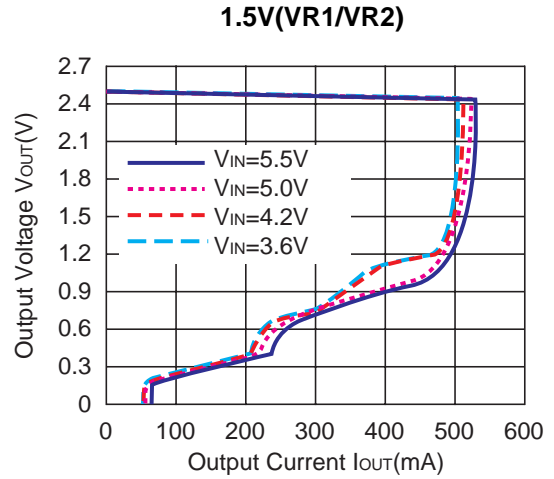
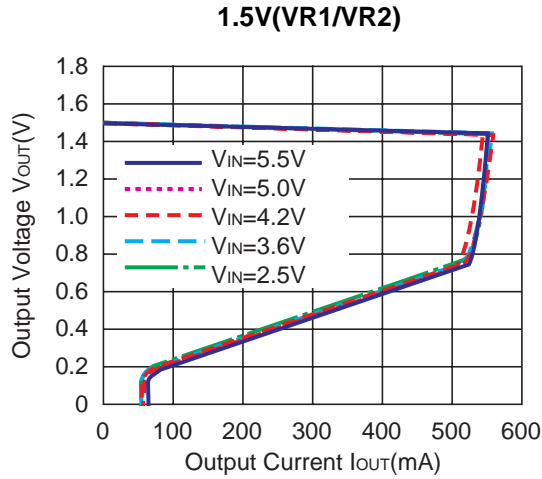

### 2) Output Voltage vs. Input Voltage (Topt=25°C)

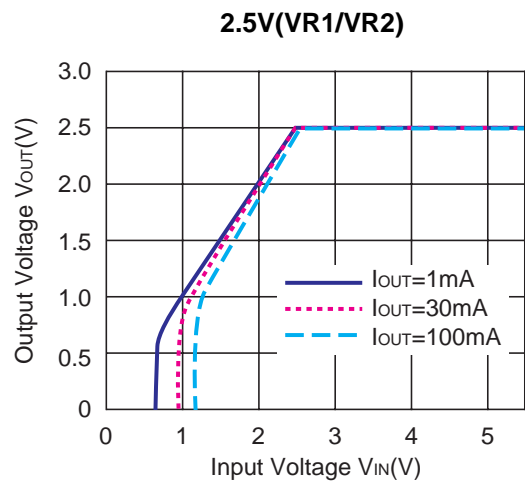
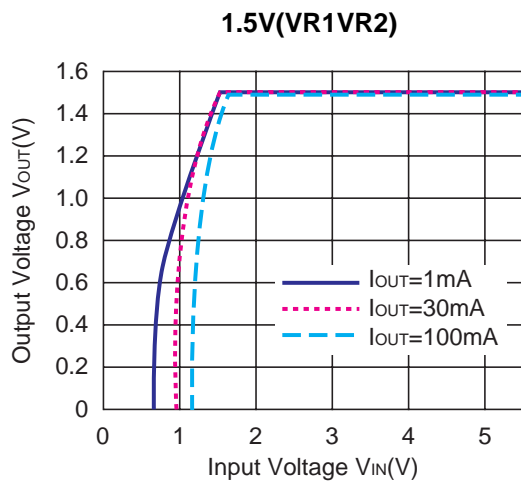

3.3V(VR1/VR2)

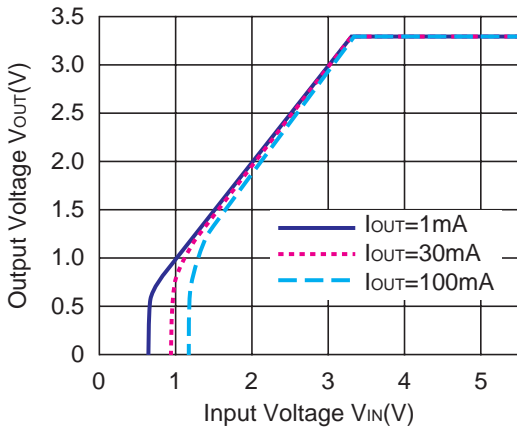

3) Supply Current vs. Input Voltage(Topt=25°C)

1.5V(VR1/VR2)

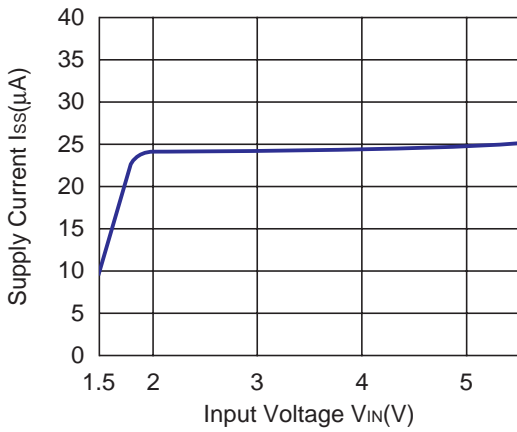

2.5V(VR1/VR2)

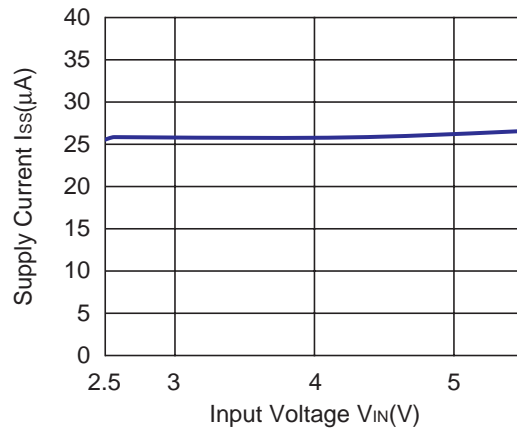

3.3V(VR1/VR2)

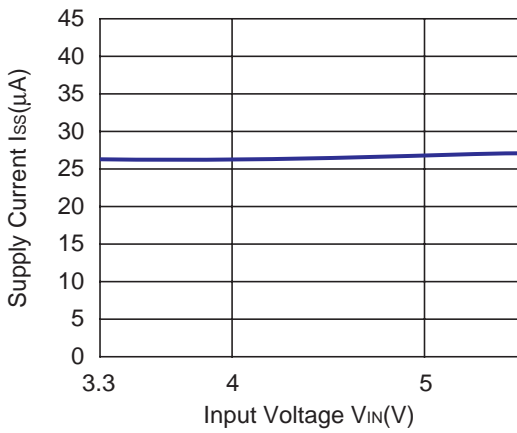

4) Output Voltage vs. Temperature

1.5V(VR1/VR2)

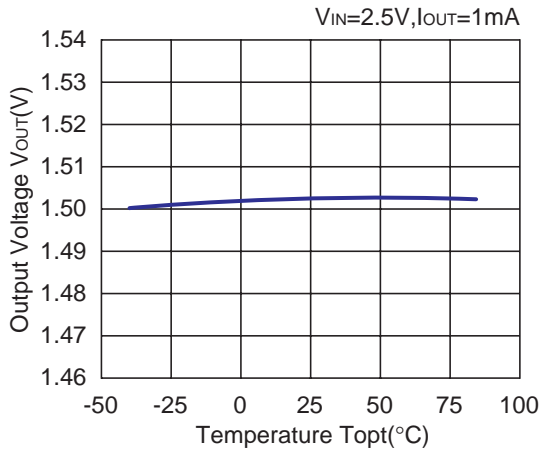

2.5V(VR1/VR2)

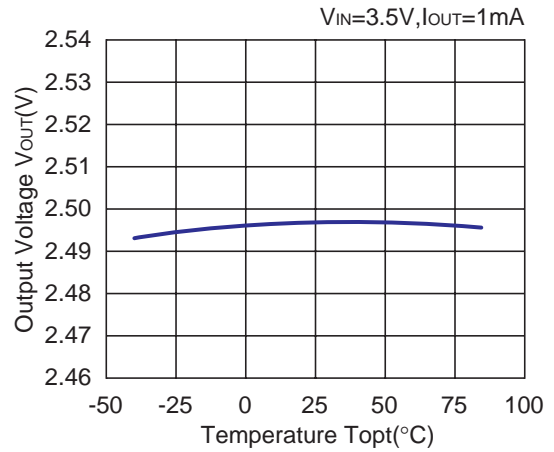

3.3V(VR1/VR2)

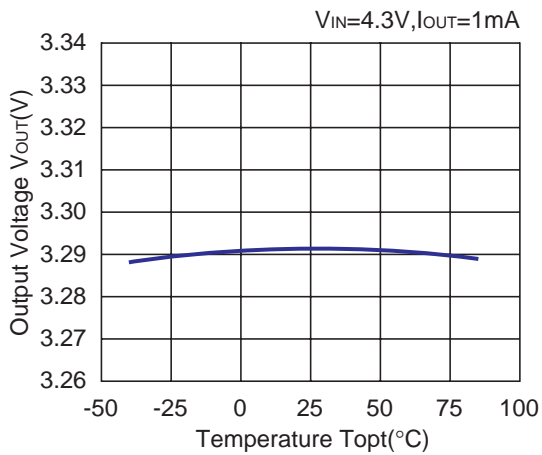

5) Supply Current vs. Temperature

1.5V(VR1/VR2)

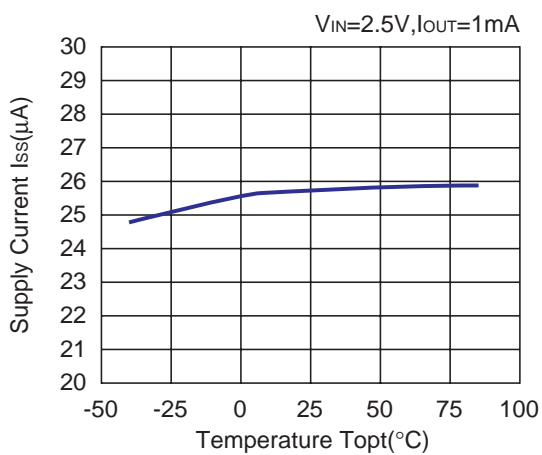

2.5V(VR1/VR2)

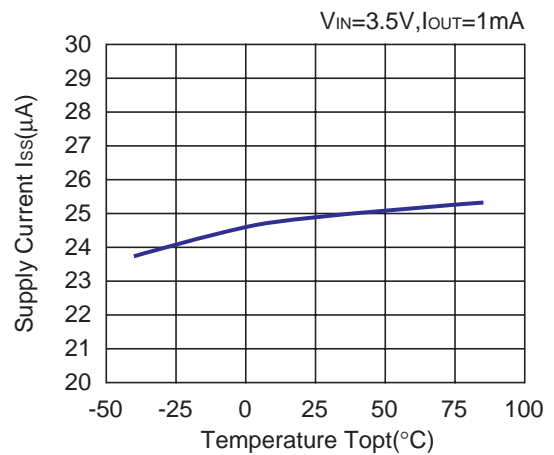

**3.3V(VR1/VR2)**

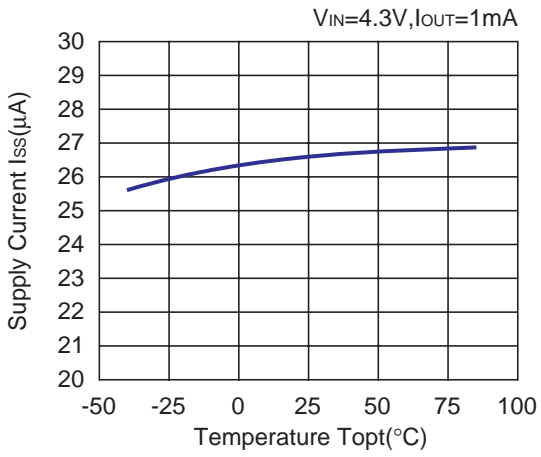

**6) Dropout Voltage vs. Output Current**

**1.5V(VR1/VR2)**

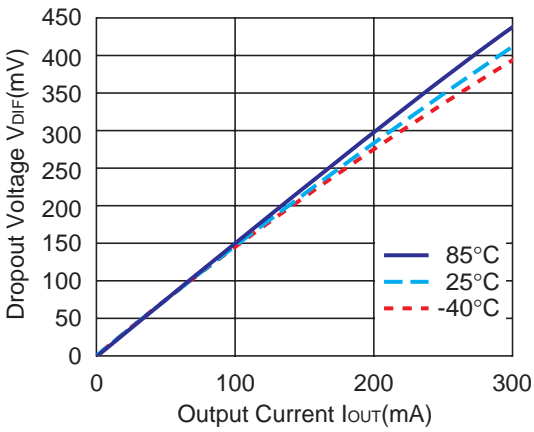

**2.5V(VR1/VR2)**

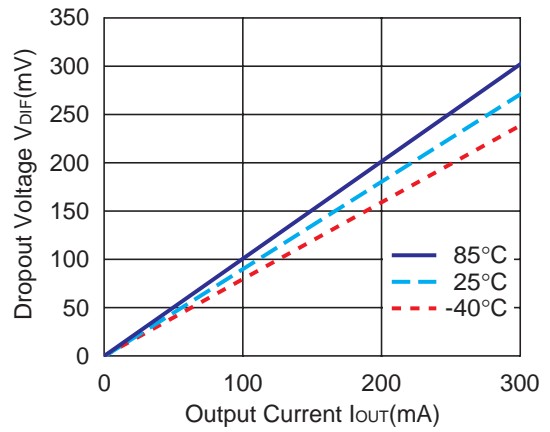

**3.3V(VR1/VR2)**

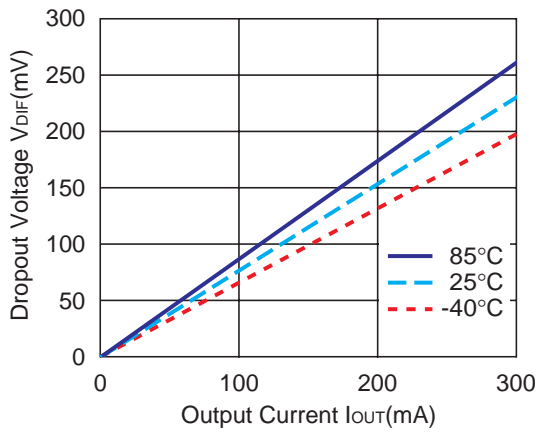

7) Dropout Voltage vs. VR\_VSET

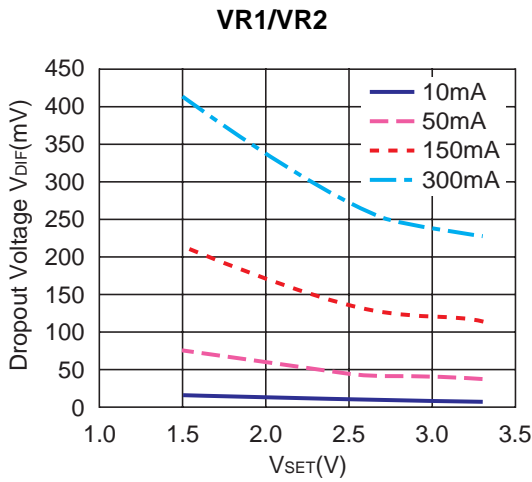

8) Ripple Rejection vs. Input Bias (Input Ripple=0.5V<sub>p-p</sub>, T<sub>opt</sub>=25°C)

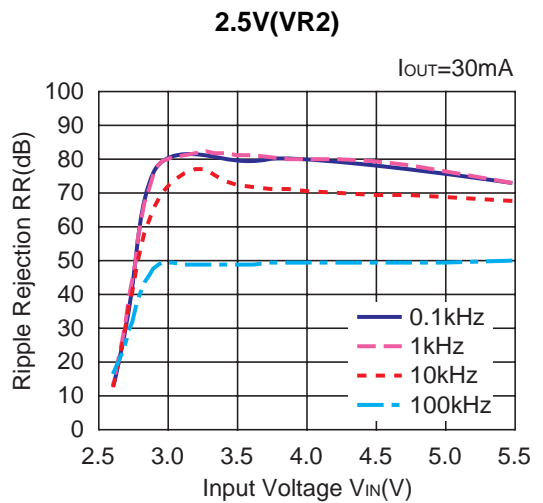
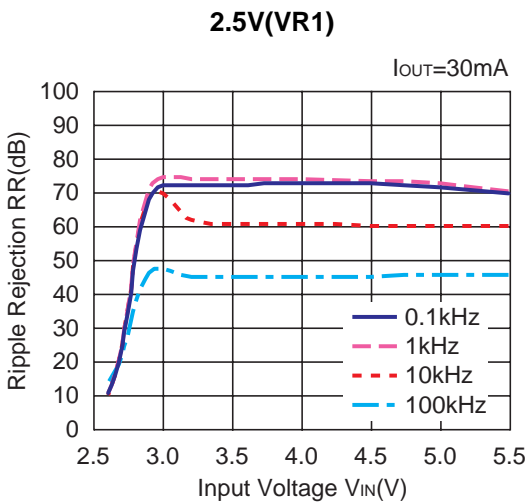
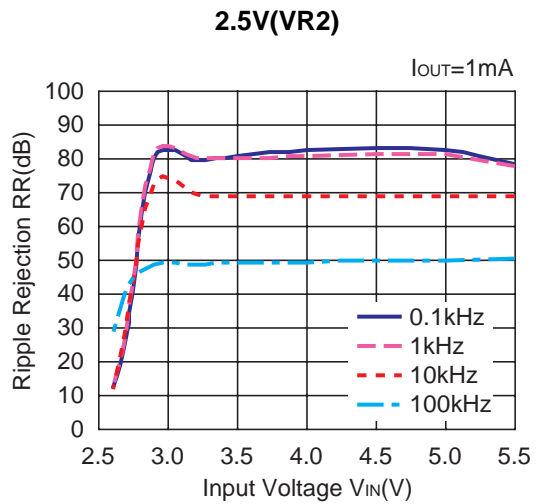
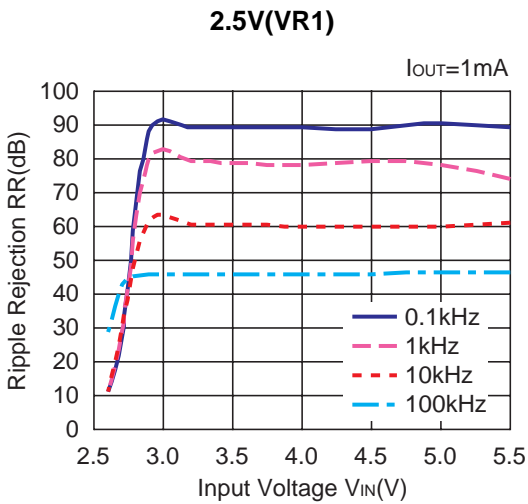

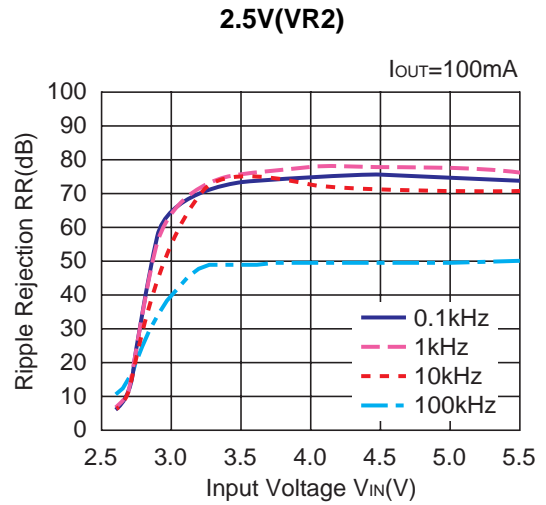
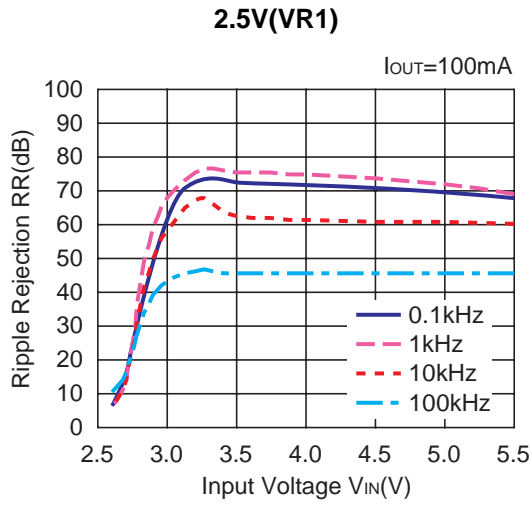

**9) Ripple Rejection vs. Frequency**

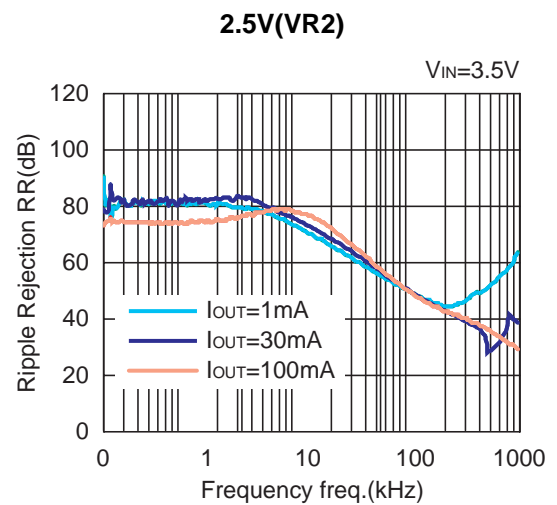
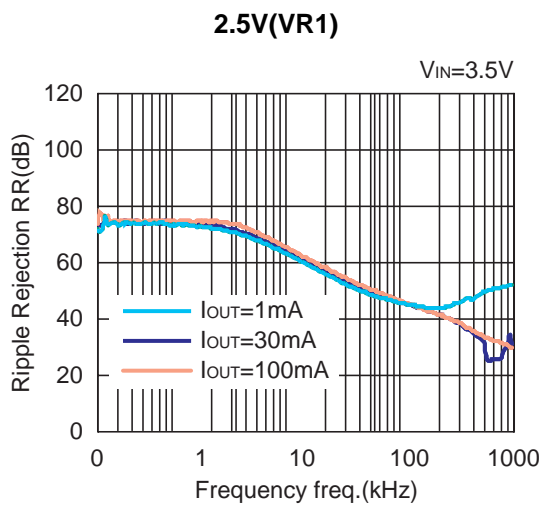
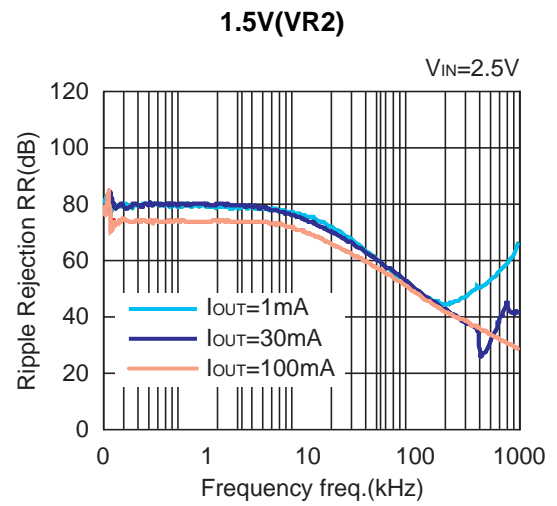
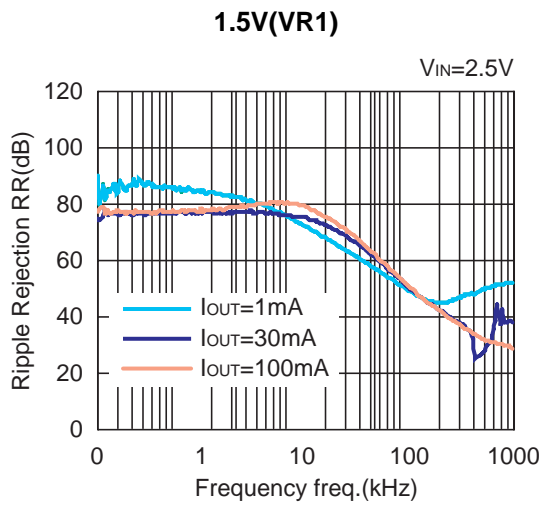

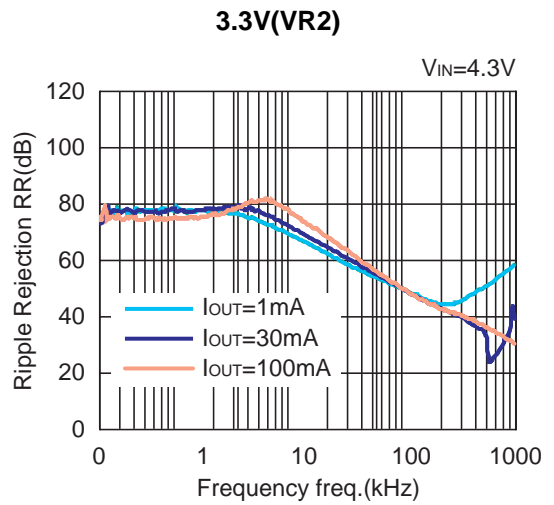
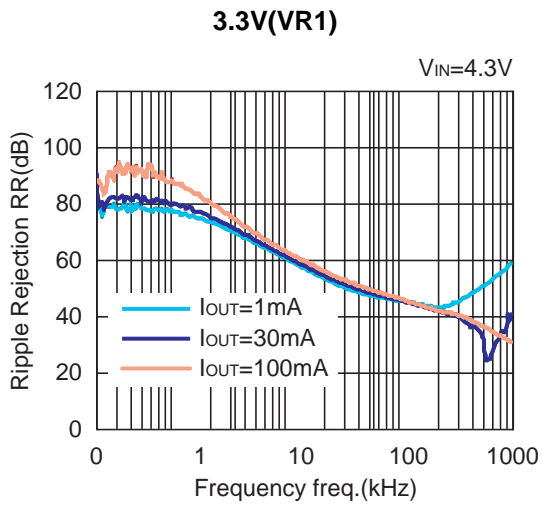

**10) Input Transient Response**

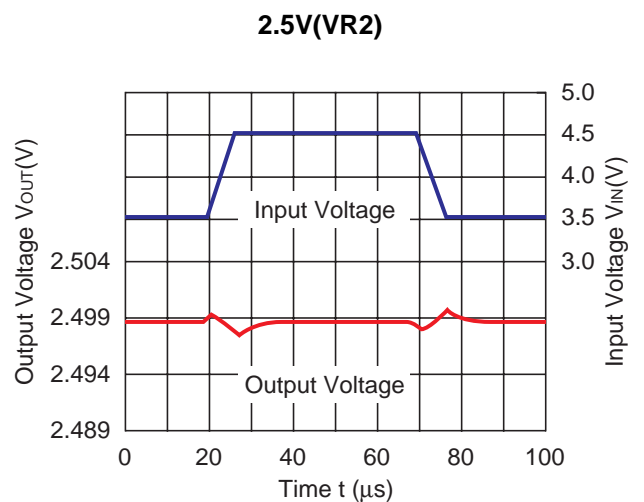
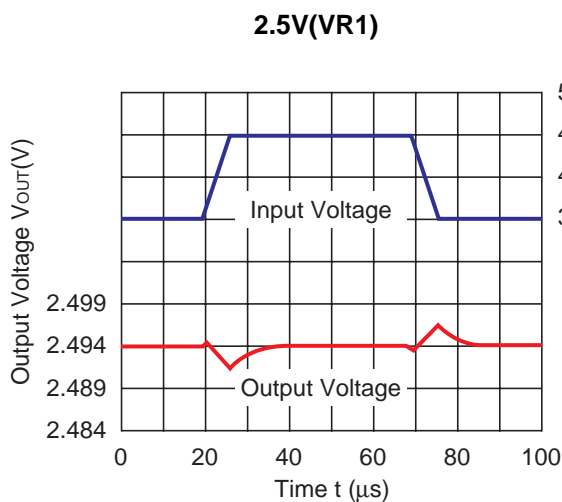
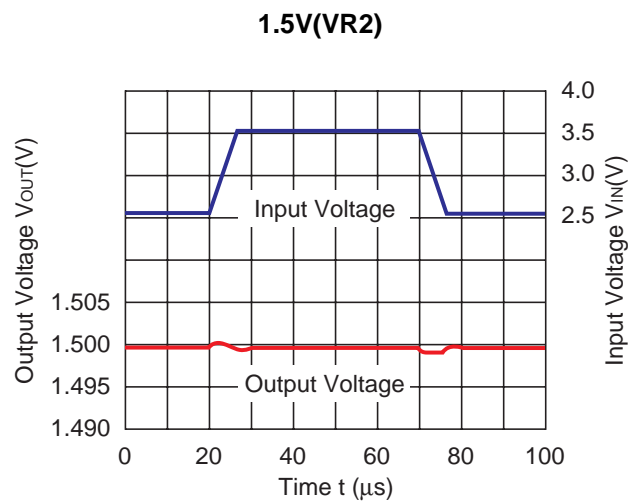
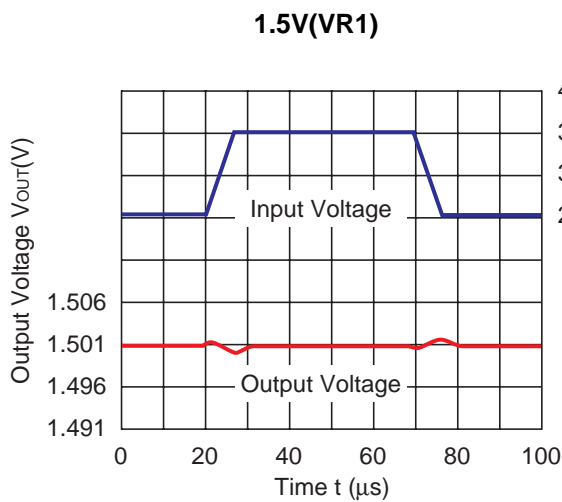

3.3V(VR1)

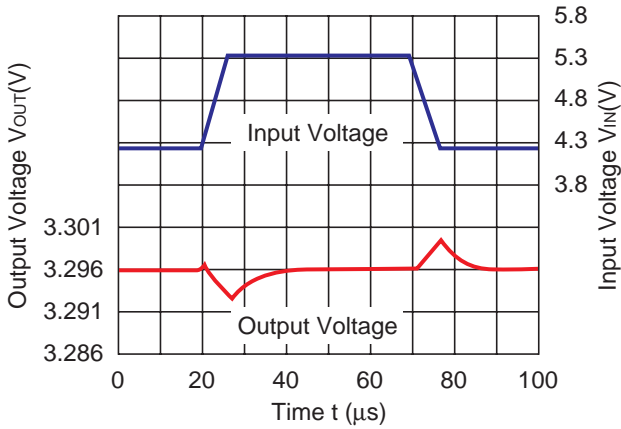

3.3V(VR2)

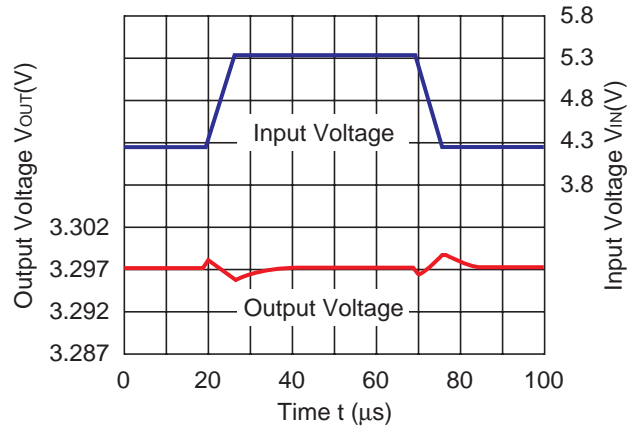

11) Load Transient Response( $T_r=T_f=500ns, T_{opt}=25^{\circ}C$ )

1.5V(VR1)

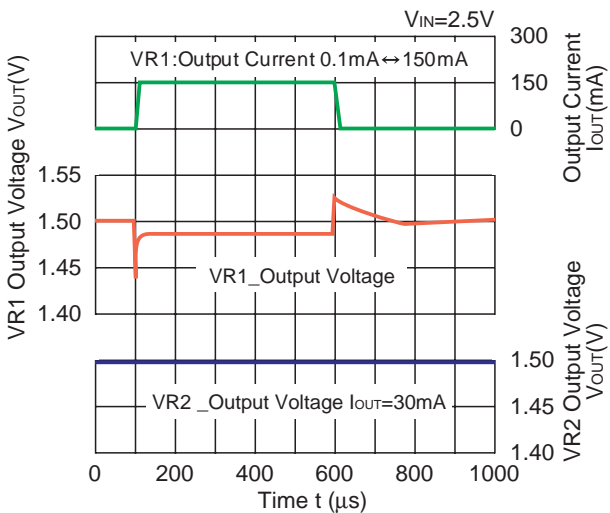

1.5V(VR2)

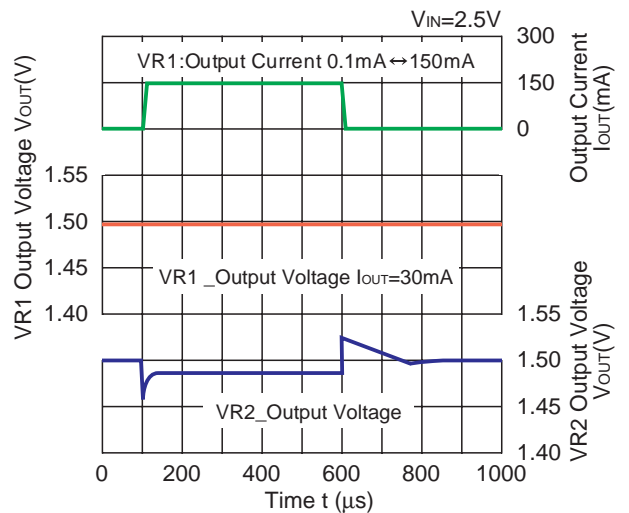

1.5V(VR1)

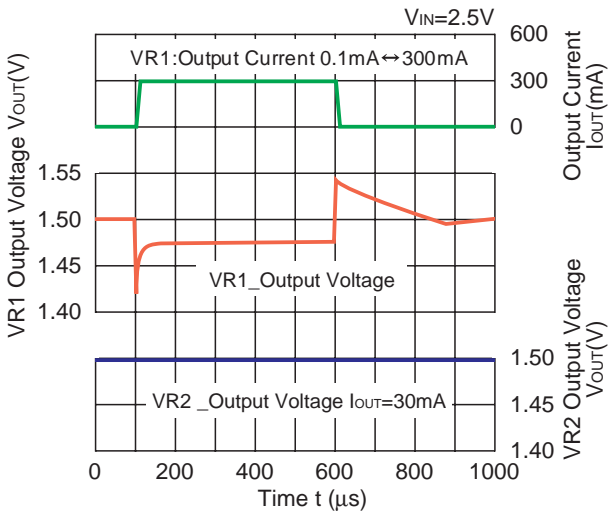

1.5V(VR2)

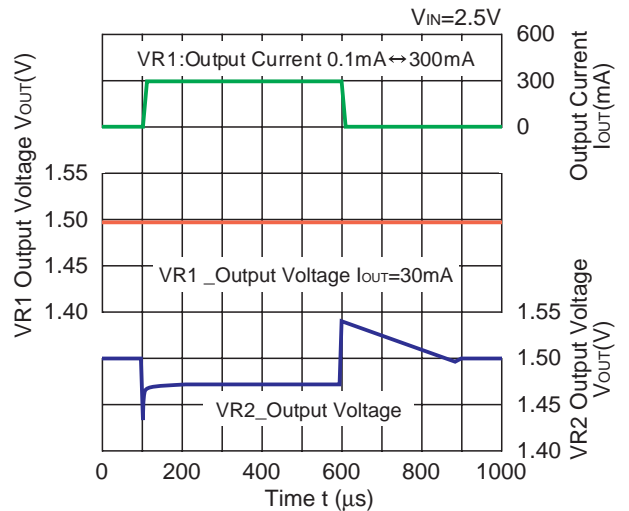



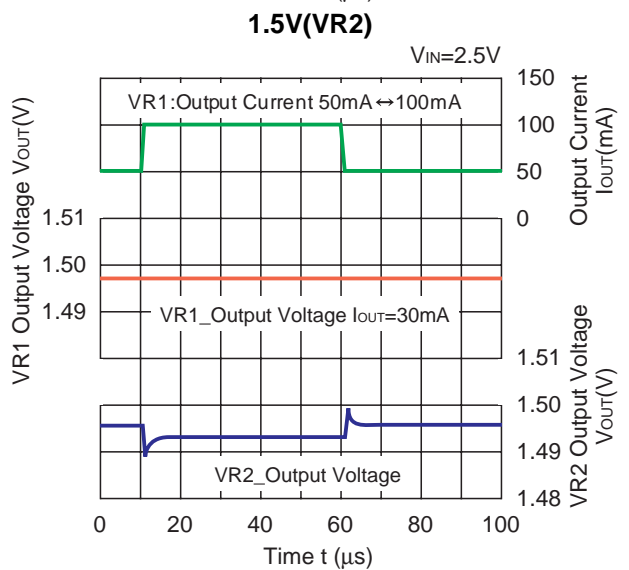
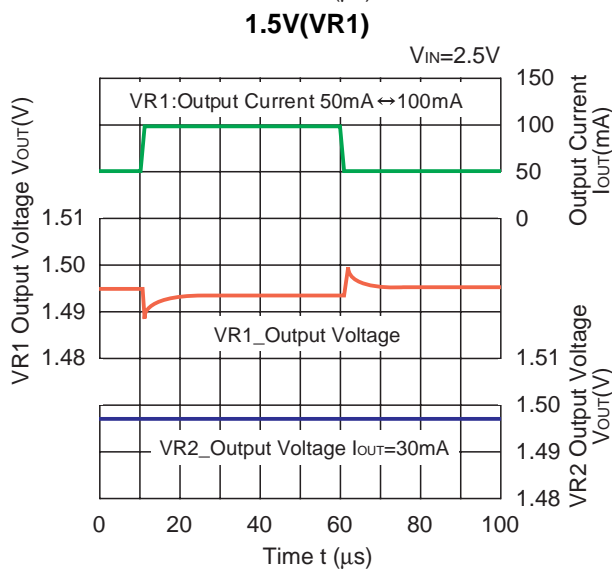
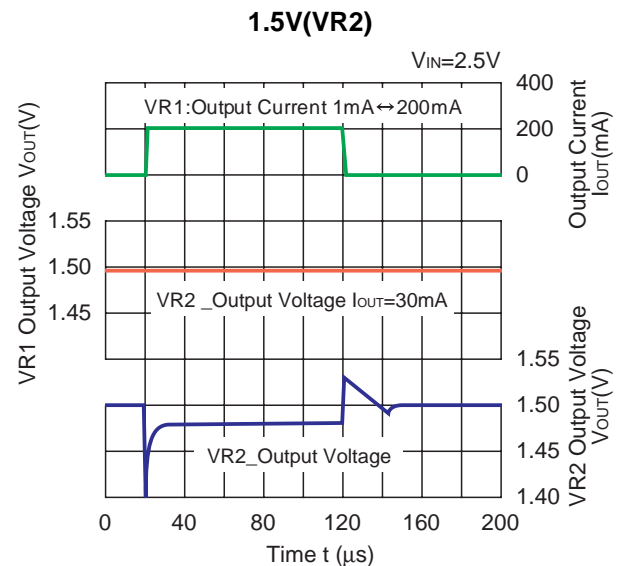
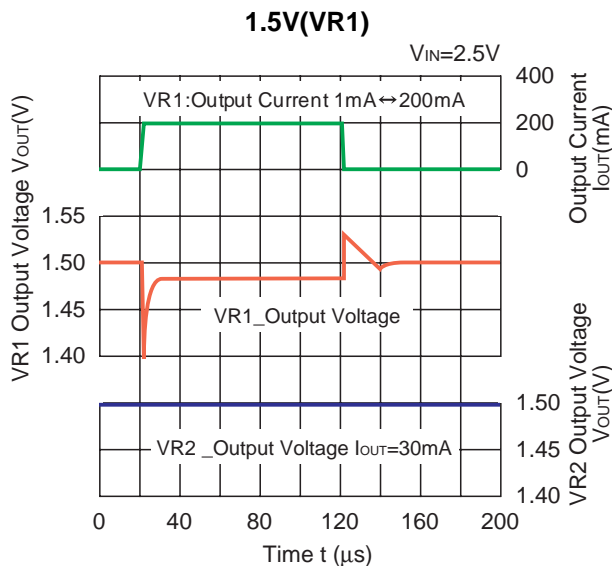
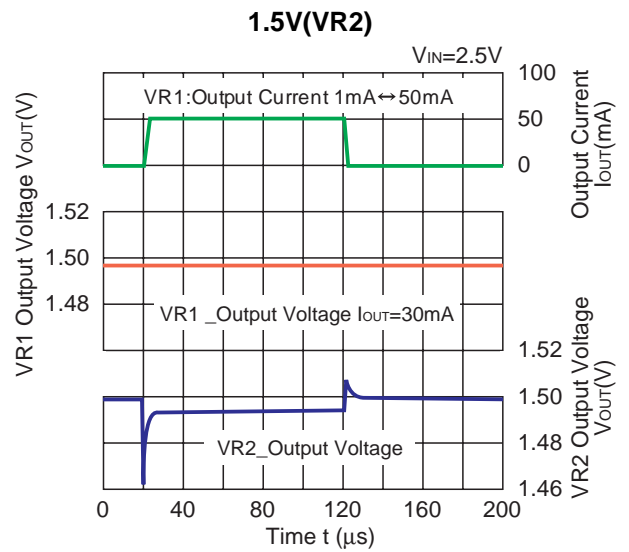
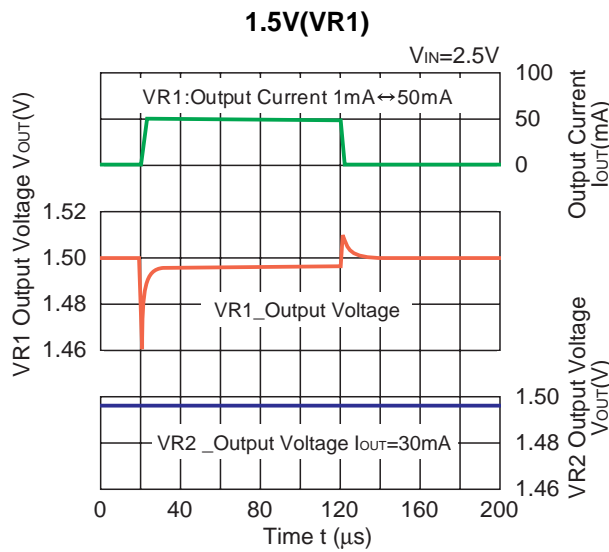

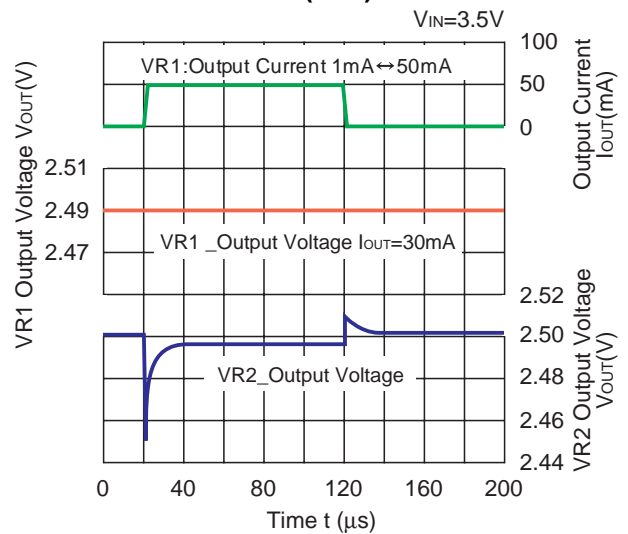
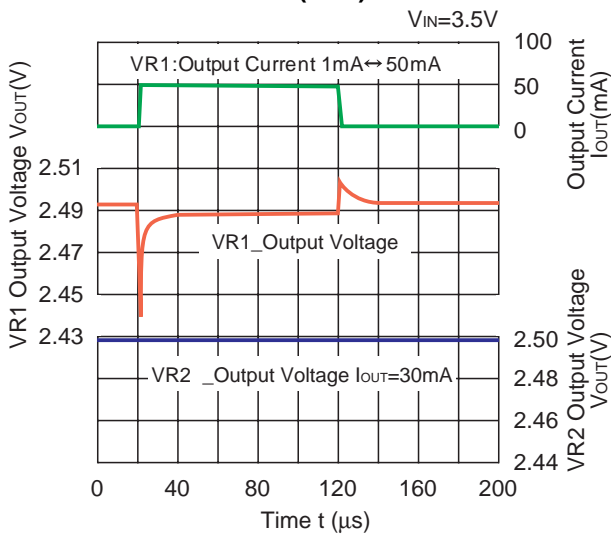
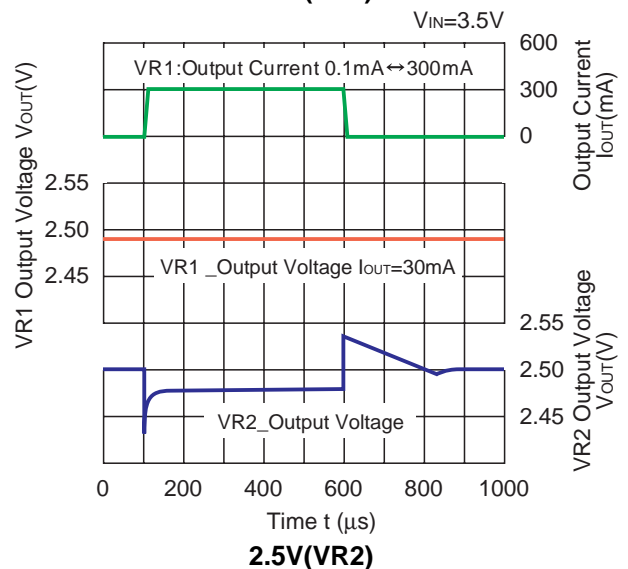
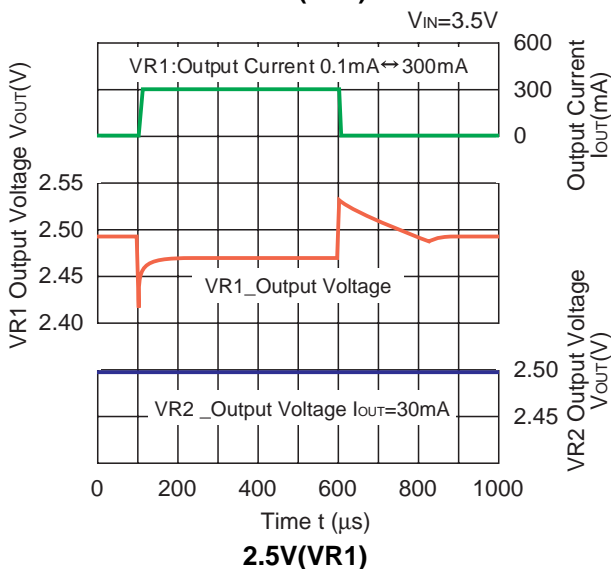
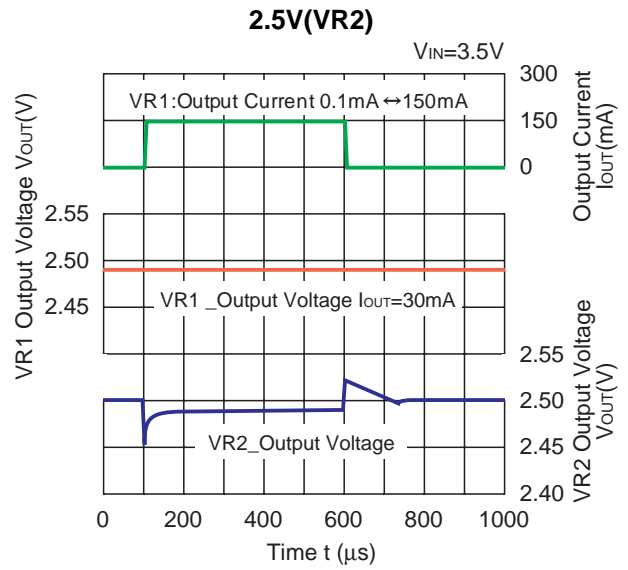
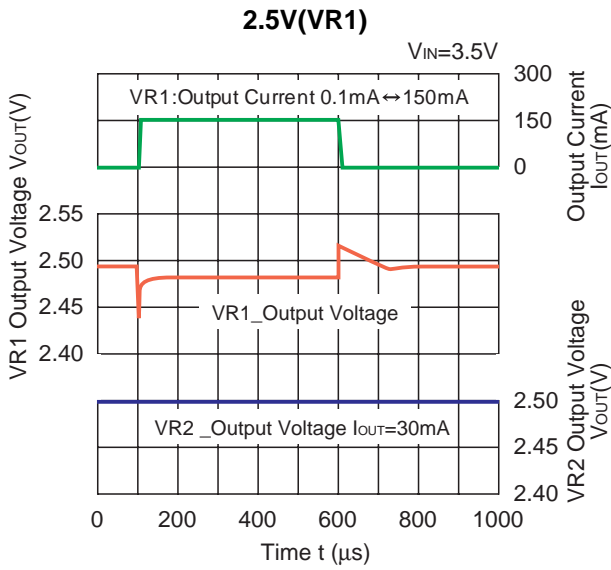

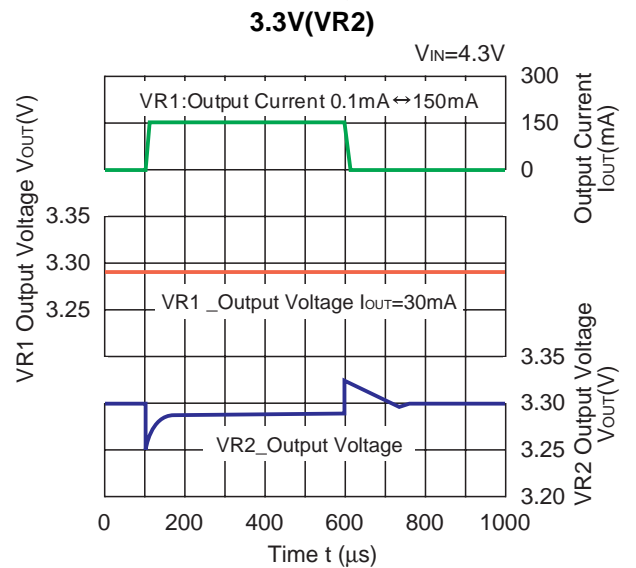
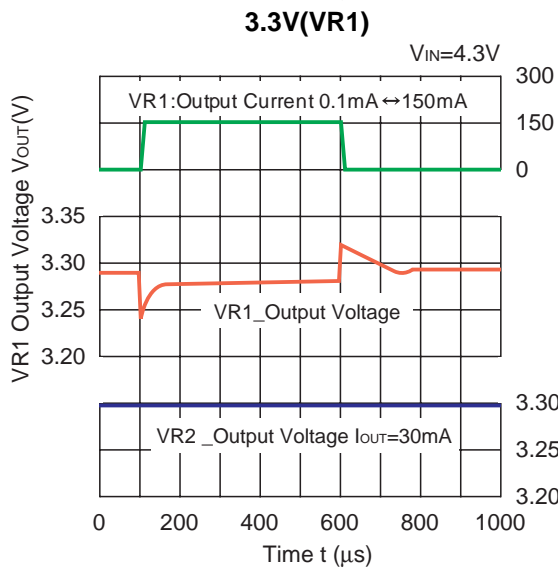
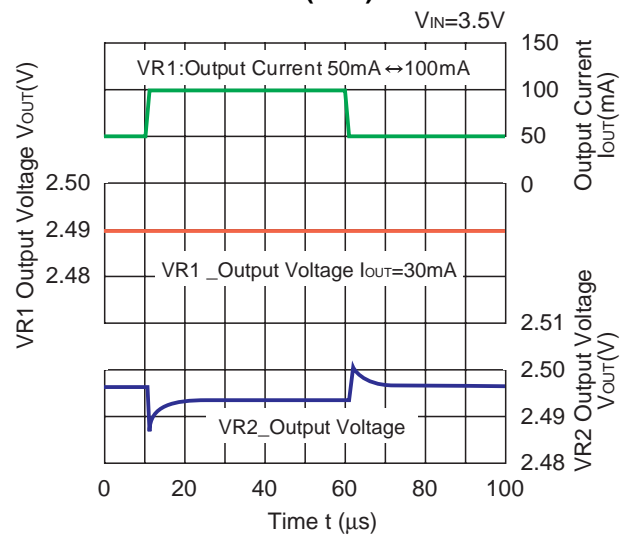
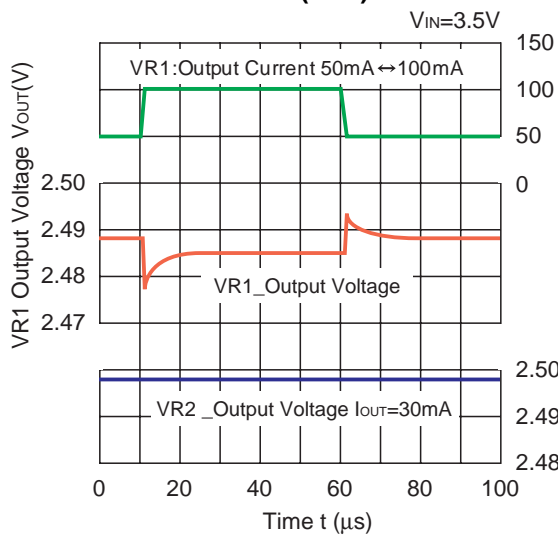
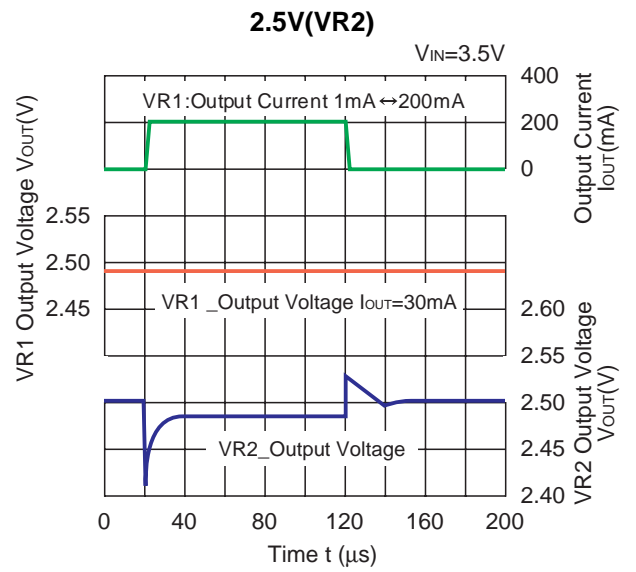
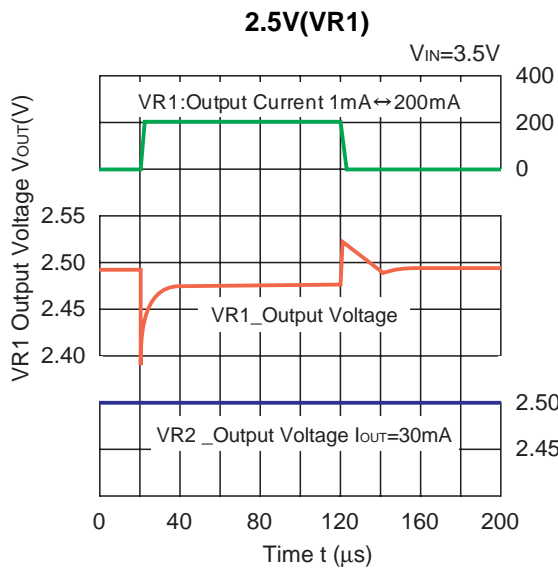

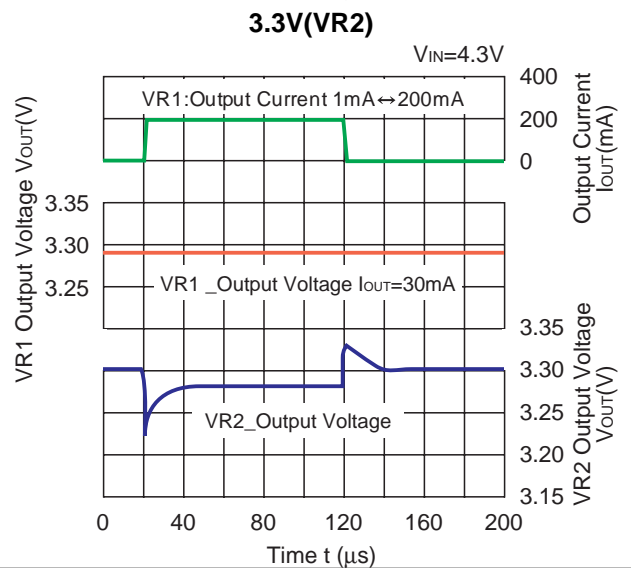
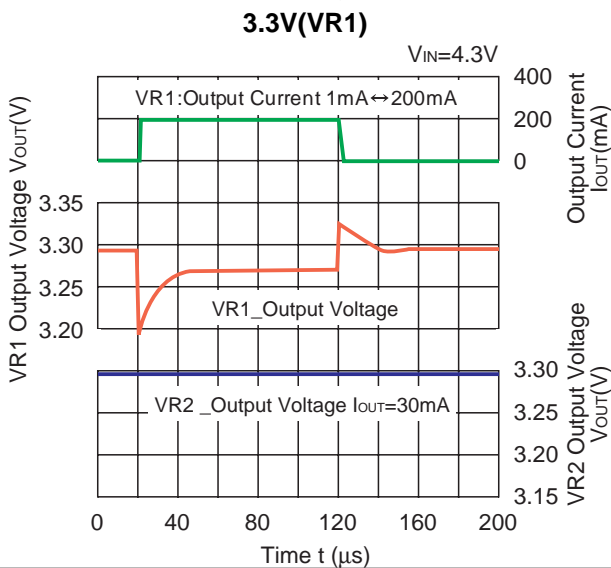
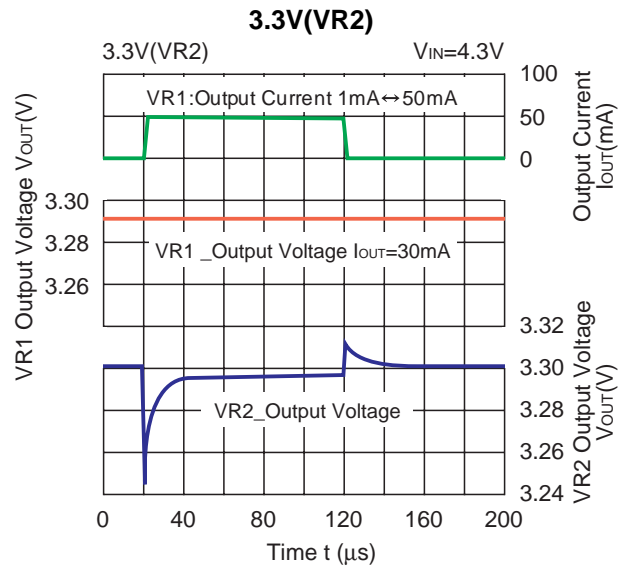
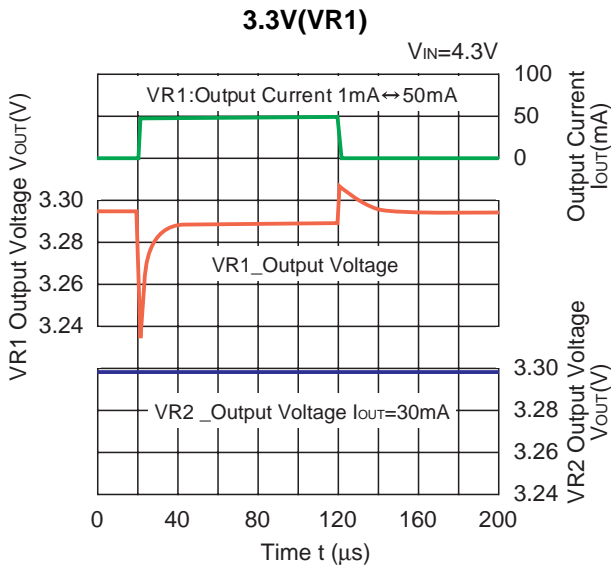
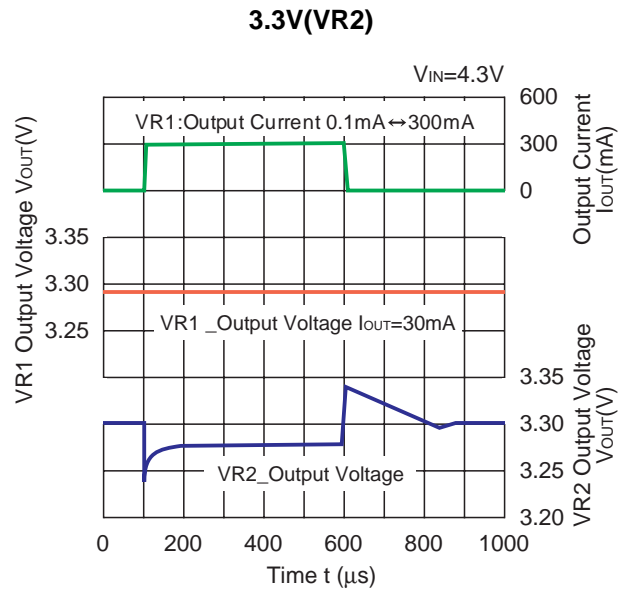
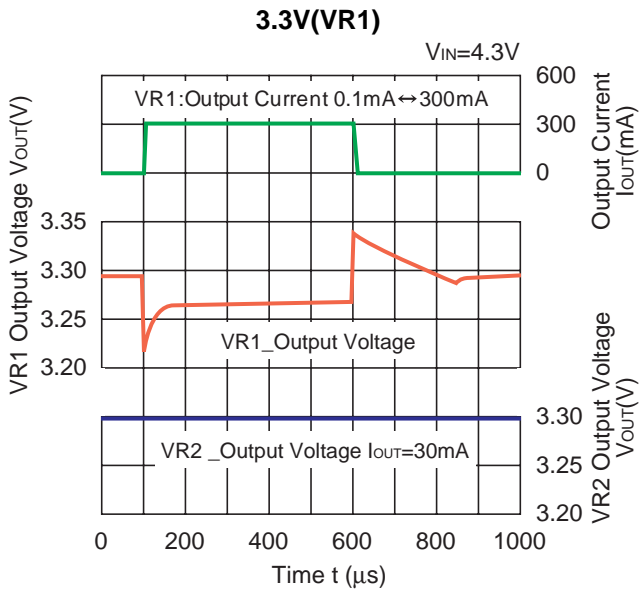

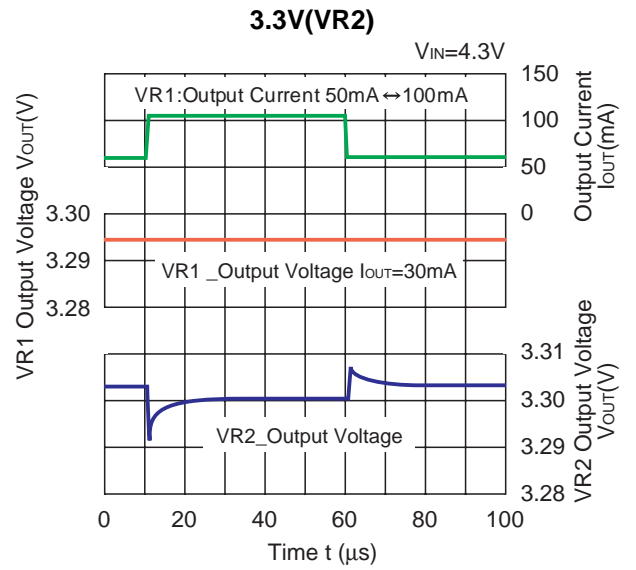
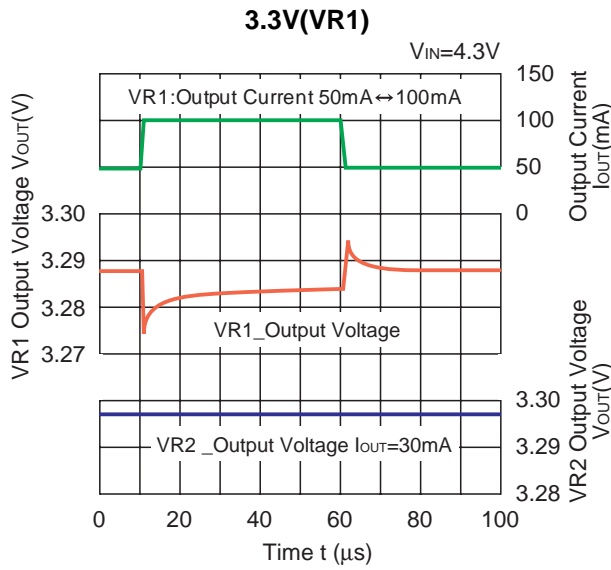

**12) Turn On Speed with CE pin ( $T_{opt}=25^{\circ}C$ )**

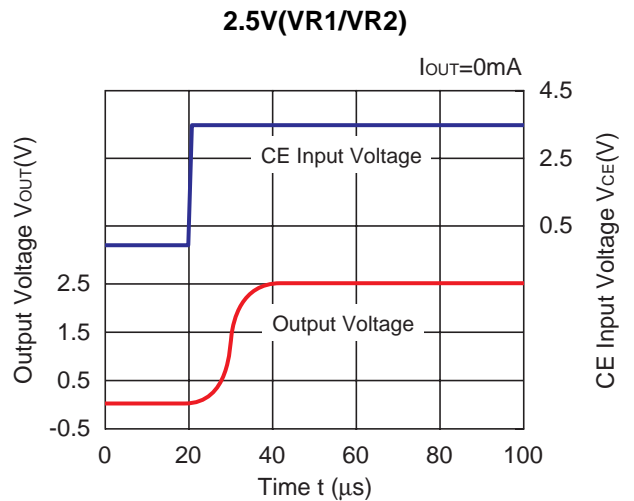
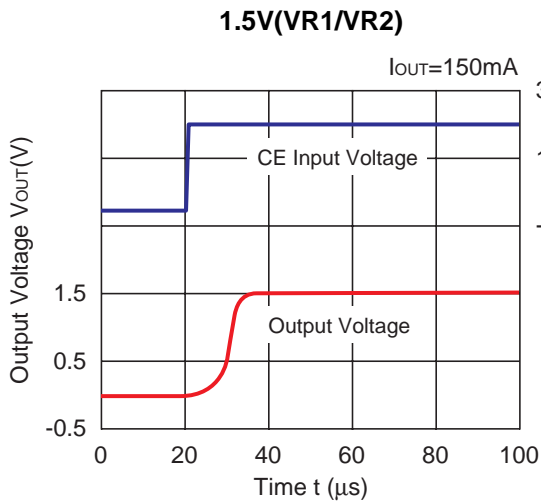
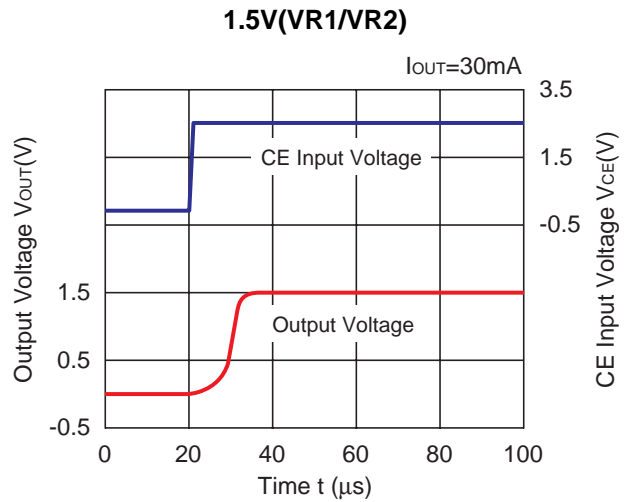
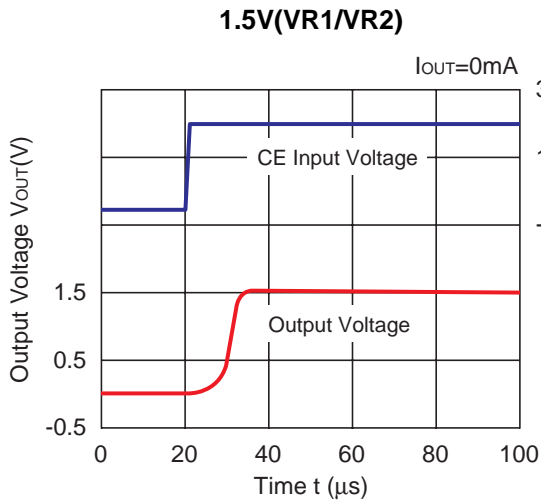

2.5V(VR1/VR2)

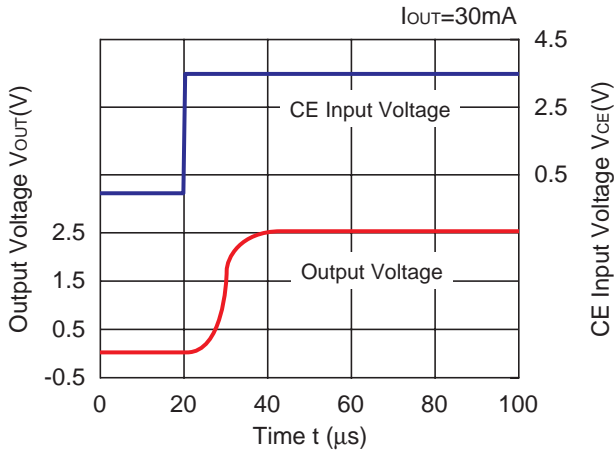

2.5V(VR1/VR2)

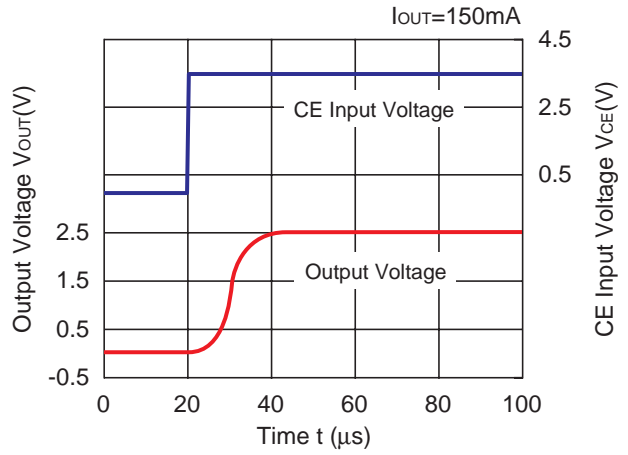

3.3V(VR1/VR2)

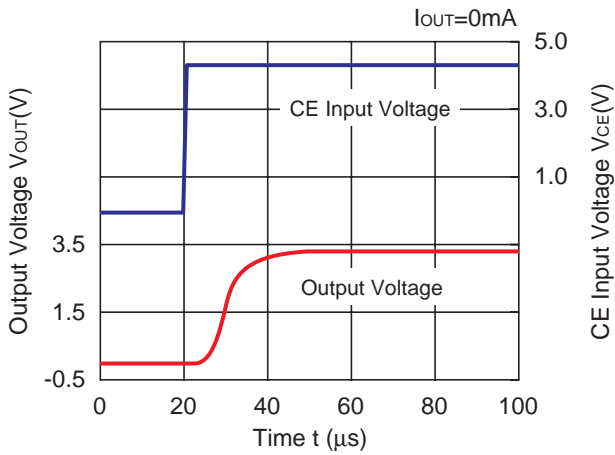

3.3V(VR1/VR2)

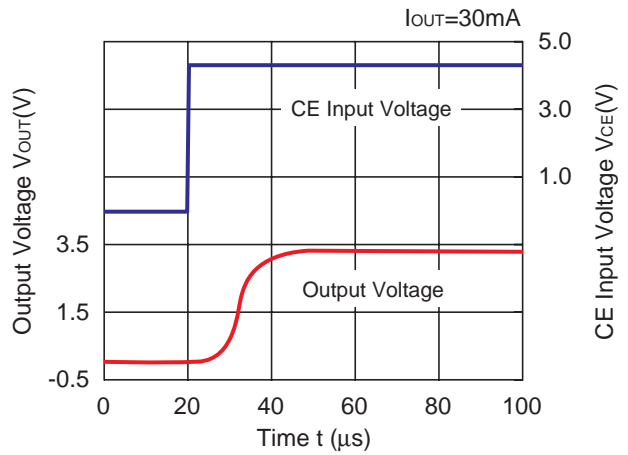

3.3V(VR1/VR2)

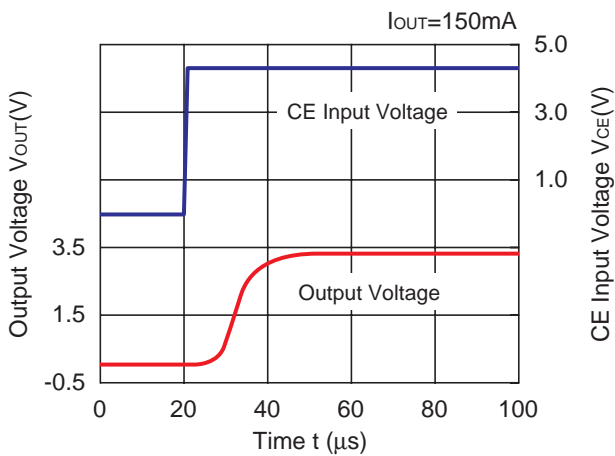

13) Turn Off Speed with CE pin (Topt=25°C)

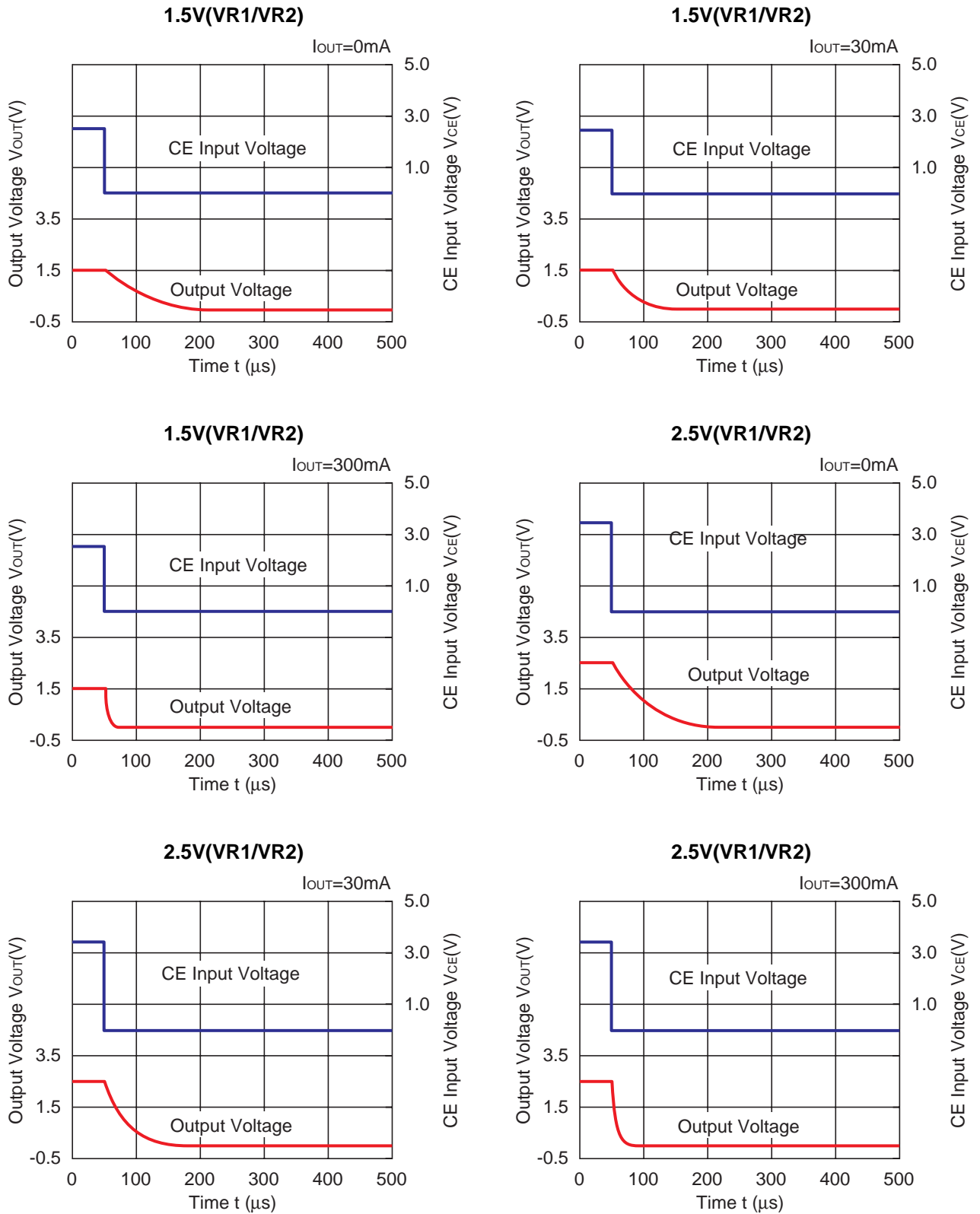

3.3V(VR1/VR2)

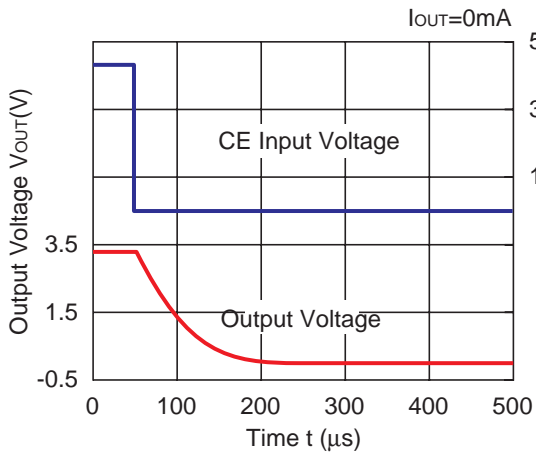

3.3V(VR1/VR2)

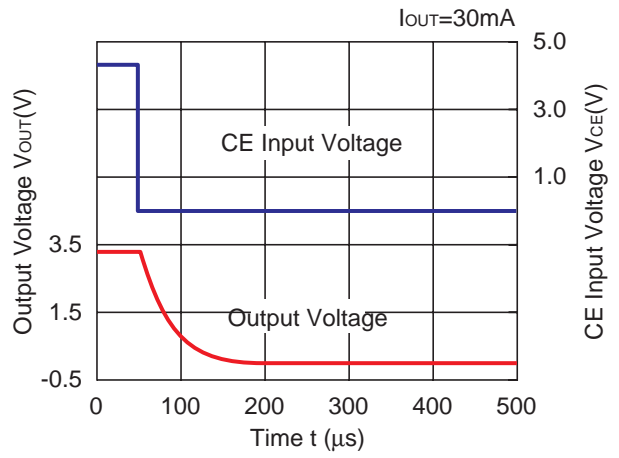

3.3V(VR1/VR2)

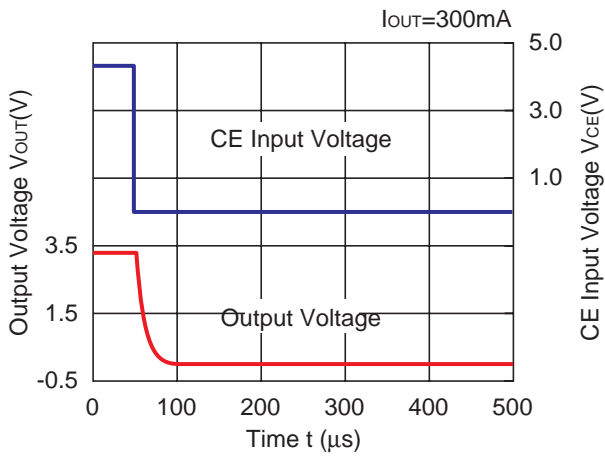



## ESR vs. Output Current

When using these ICs, consider the following points:

The relations between  $I_{OUT}$  (Output Current) and ESR of an output capacitor are shown below.

The conditions when the white noise level is under  $40\mu\text{V}$  (Avg.) are marked as the hatched area in the graph.

### Measurement conditions

$V_{IN} = \text{Set } V_{OUT} + 1\text{V}$

Frequency Band: 10Hz to 30MHz

Temperature:  $-40^{\circ}\text{C}$  to  $85^{\circ}\text{C}$

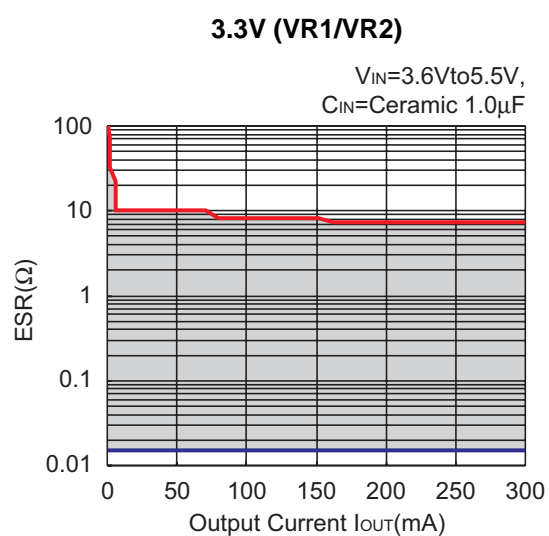
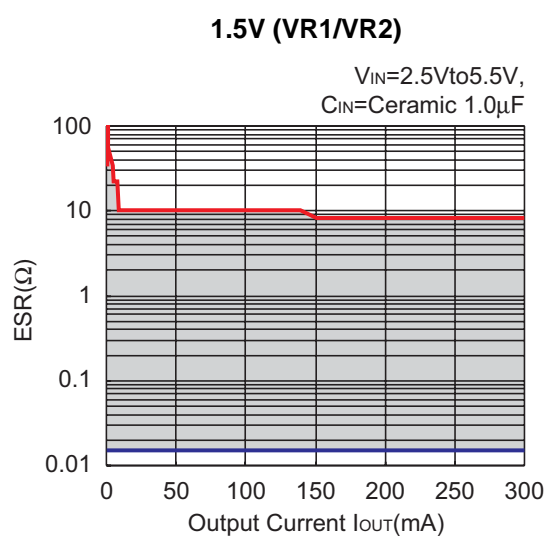



## POWER DISSIPATION (PLP2020-8)

This specification is at mounted on board. Power Dissipation ( $P_D$ ) depends on conditions of mounting on board.

This specification is based on the measurement at the condition below:

(Power Dissipation (PLP2020-8) is substitution of PLP1820-6.)

### Measurement Conditions

	Standard Land Pattern
Environment	Mounting on Board (Wind velocity=0m/s)
Board Material	Glass cloth epoxy plastic (Double sided)
Board Dimensions	40mm × 40mm × 1.6mm
Copper Ratio	Top side : Approx. 50% , Back side : Approx. 50%
Through-hole	φ0.54mm × 30pcs

### Measurement Result

( $T_{opt}=25^{\circ}\text{C}$ ,  $T_{jmax}=125^{\circ}\text{C}$ )

	Standard Land Pattern
Power Dissipation	880mW
Thermal Resistance	$\theta_{ja}=(125-25^{\circ}\text{C})/0.88\text{W}=114^{\circ}\text{C/W}$

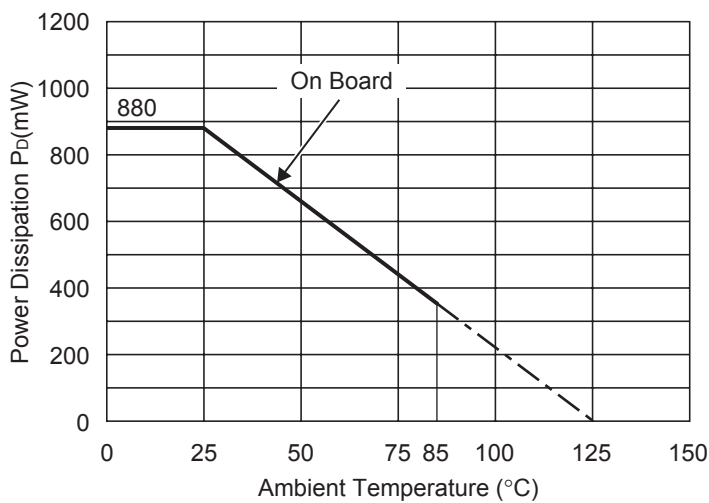

Power Dissipation

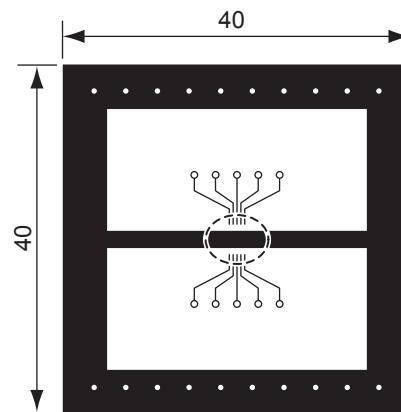

Measurement Board Pattern

○ IC Mount Area Unit : mm

## RECOMMENDED LAND PATTERN

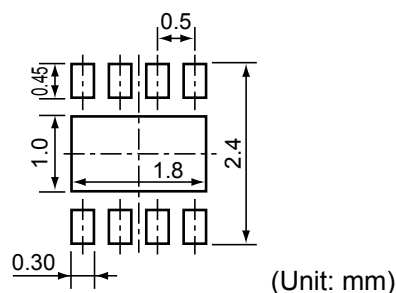

RP150K SERIES MARK SPECIFICATION

● PLP2020-8

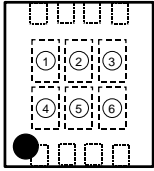

① to ④ : Product Code (refer to Part Number vs. Product Code)

⑤, ⑥ : Lot Number

● Part Number vs. Product Code

Part Number	Product Code				Set V <sub>OUT</sub>	
	①	②	③	④	VR1	VR2
RP150K001A	H	0	0	1	2.85	2.85
RP150K002A	H	0	0	2	3.0	3.0
RP150K003A	H	0	0	3	3.3	3.3
RP150K004A	H	0	0	4	2.5	1.8
RP150K005A	H	0	0	5	2.8	2.6
RP150K006A	H	0	0	6	1.5	2.8
RP150K007A	H	0	0	7	3.3	1.8
RP150K008A	H	0	0	8	1.8	2.8
RP150K009A	H	0	0	9	3.3	2.8
RP150K010A	H	0	1	0	3.3	3.0
RP150K011A	H	0	1	1	2.8	2.8
RP150K012A	H	0	1	2	2.7	3.3
RP150K013A	H	0	1	3	1.7	1.8
RP150K014A	H	0	1	4	1.8	1.8
RP150K015A	H	0	1	5	1.8	2.6
RP150K016A	H	0	1	6	2.8	3.0
RP150K017A	H	0	1	7	1.8	3.0

Part Number	Product Code				Set V <sub>OUT</sub>	
	①	②	③	④	VR1	VR2
RP150K001B	A	A	0	1	2.85	2.85
RP150K002B	A	A	0	2	3.0	3.0
RP150K003B	A	A	0	3	3.3	3.3
RP150K004B	A	A	0	4	2.5	1.8
RP150K005B	A	A	0	5	2.8	2.6
RP150K006B	A	A	0	6	1.5	2.8
RP150K007B	A	A	0	7	3.3	1.8
RP150K008B	A	A	0	8	1.8	2.8
RP150K009B	A	A	0	9	3.3	2.8
RP150K010B	A	A	1	0	3.3	3.0
RP150K011B	A	A	1	1	2.8	2.8
RP150K012B	A	A	1	2	2.7	3.3
RP150K013B	A	A	1	3	1.7	1.8
RP150K014B	A	A	1	4	1.8	1.8
RP150K015B	A	A	1	5	1.8	2.6
RP150K016B	A	A	1	6	2.8	3.0
RP150K017B	A	A	1	7	1.8	3.0