

## **Contents**

Features .....	1
Applications .....	1
Block Diagram .....	1
Selection Guide .....	2
Pin Assignment .....	3
Absolute Maximum Ratings .....	3
Electrical Characteristics .....	4
Test Circuits .....	9
Operation.....	9
External Parts Selection for DC-DC Converter ....	12
Standard Circuits .....	16
Precautions .....	18
Application Circuits .....	19
Dimensions.....	24
Markings.....	24
Taping .....	25
Temperature Characteristics .....	28
Characteristics for the Power Voltage.....	30
Ripple characteristics .....	31
Transient Responses.....	32
Operation Start Voltage and Operation Holding Voltage Characteristics for Output Current .....	34
Input Voltage Characteristics for Input Current ....	34
Reference Data .....	35
Frequently Asked Questions .....	48

The S-8324/8328 is a series of CMOS PWM/PFM-control step-up switching regulators which mainly consist of a reference voltage source, an oscillation circuit, a power MOS FET (S-8324 Series) and an error amplifier. The new method PWM/PFM control circuit automatically switches the control method according to the current load, offering products of a wide range, high efficiency. A step-up switching regulator is constructed by externally connecting only a coil, a capacitor and a diode to the S-8324 Series. This feature, along with its small package and low current consumption, makes the S-8324 Series ideal for the power supply of portable equipment. For applications requiring a high output current, products used with an external transistor (S-8328 Series) are also available.

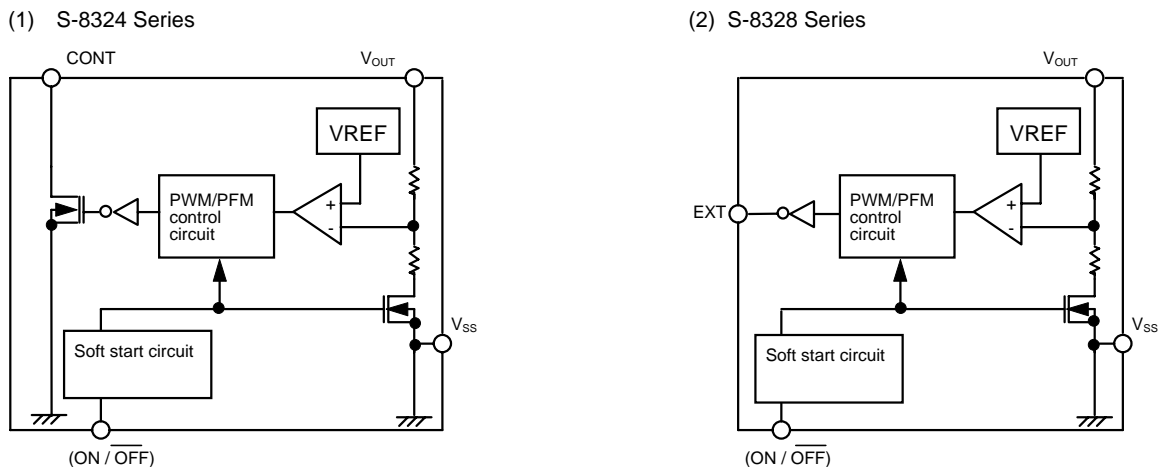
■ **Features**

- Low voltage operation : 0.9 V ( $I_{OUT} = 1\text{mA}$ )
- Low current consumption :
  - During operation : 17.2 $\mu\text{A}$  (typ.)  
( $V_{OUT} = 3\text{V}$ , 50 kHz)
  - During shutdown : 0.5 $\mu\text{A}$  (max.)
- Low Input current : 10.4 $\mu\text{A}$  (typ.)  
( $V_{OUT} = 3\text{V}$ , 50 kHz, no load)
- Duty ratio :
  - During PWM control : 15 to 83 % typ.
  - During PFM control : 15 % typ.
- External parts: coil, diode, and capacitor only  
(a transistor is needed for the S-8328 Series.)
- Output voltage: accuracy of  $\pm 2.4\%$
- Software start function : 6 msec (typ.)
- Shutdown function
- External transistor type is available (S-8328 Series)
- SOT-23-5 small plastic package
- SOT-23-3 small plastic package
- SOT-89-3 miniature power molded plastic package
- Step-down and invert type are also available.

■ **Applications**

- Power supplies for portable equipment such as pagers, handy calculators, and remote controllers
- Constant voltage power supplies for cameras, video equipment, and communications equipment
- Power supply for microcomputers

■ **Block Diagram**



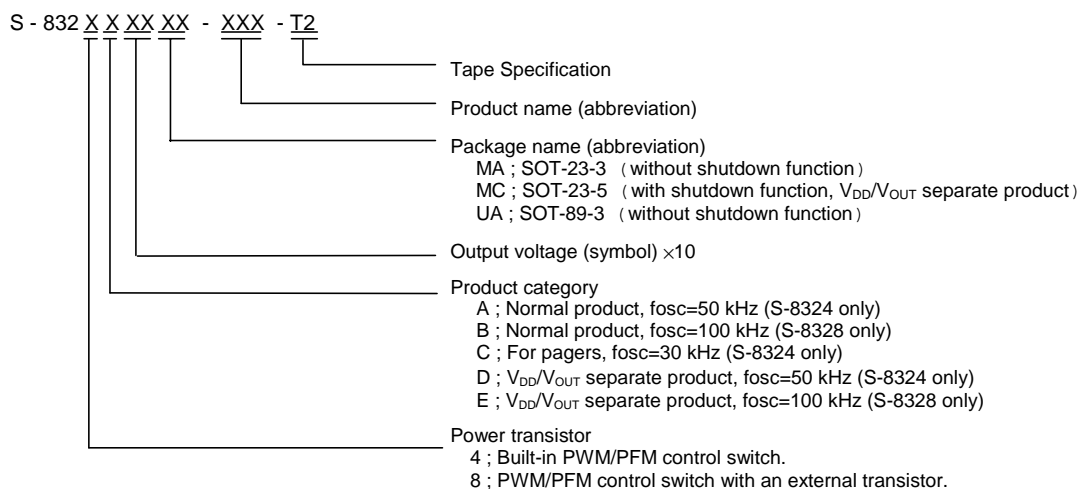
**Figure 1 Block Diagram**

# SMALL PACKAGE PWM/PFM CONTROL STEP-UP SWITCHING REGULATOR

## S-8324/8328 Series

### ■ Selection Guide

#### 1. Product Name



#### 2. Product List

Output voltage(v)	S-8324AXXMC Series	S-8324AXXMA Series	S-8324AXXUA Series	S-8324CXXMA Series	S-8324DXXMC Series
2.0	—	—	—	—	S-8324D20MC-E2A-T2
2.5	S-8324A25MC-EOF-T2	S-8324A25MA-EOF-T2	S-8324A25UA-EOF-T2	S-8324C25MA-EQF-T2	—
2.7	S-8324A27MC-EOH-T2	S-8324A27MA-EOH-T2	S-8324A27UA-EOH-T2	S-8324C27MA-EQH-T2	—
2.8	S-8324A28MC-EOI-T2	—	—	—	—
3.0	S-8324A30MC-EOK-T2	S-8324A30MA-EOK-T2	S-8324A30UA-EOK-T2	S-8324C30MA-EQK-T2	S-8424D30MC-E2K-T2
3.3	S-8324A33MC-EON-T2	S-8324A33MA-EON-T2	S-8324A33UA-EON-T2	—	—
5.0	S-8324A50MC-EPE-T2	S-8324A50MA-EPE-T2	S-8324A50UA-EPE-T2	—	S-8324D50MC-E4E-T2

Output voltage(v)	S-8328BXXMC Series	S-8328BXXMA Series	S-8328BXXUA Series	S-8328EXXMC Series
2.0	—	—	—	S-8328E20MC-EYA-T2
2.5	S-8328B25MC-EWF-T2	S-8328B25MA-EWF-T2	S-8328B25UA-EWF-T2	—
2.7	S-8328B28MC-EWH-T2	S-8328B28MA-EWH-T2	S-8328B28UA-EWH-T2	—
3.0	S-8328B30MC-EWK-T2	S-8328B30MA-EWK-T2	S-8328B30UA-EWK-T2	—
3.3	S-8328B33MC-EWN-T2	S-8328B33MA-EWN-T2	S-8328B33UA-EWN-T2	—
3.6	S-8328B36MC-EWQ-T2	—	—	—
3.8	S-8328B38MC-EWS-T2	—	—	—
5.0	S-8328B50MC-EXE-T2	S-8328B50MA-EXE-T2	S-8328B50UA-EXE-T2	S-8328E50MC-E9E-T2
5.2	S-8328B52MC-EXG-T2	—	—	—

Consult our sales person for products with an output voltage other than specified above.

#### 3. Function List

Product Name	Built In power transistor	with external power transistor	Switching frequency (KHz)	Shutdown function	$V_{DD}/V_{OUT}$ separate type	Package	Application	Reference page
S-8324AXXMC	Yes	—	50	Yes	—	SOT-23-5	With a shutdown function	—
S-8324AXXMA	Yes	—	50	—	—	SOT-23-3	without shutdown function	—
S-8324AXXUA	Yes	—	50	—	—	SOT-89-3	without shutdown function	—
S-8324DXXMC	Yes	—	50	—	Yes	SOT-23-5	For variable output voltage by step-up DC/DC converter and step-down inverted output DC/DC converter with an external resistor	Page.15
S-8324CXXMA	Yes	—	30	—	—	SOT-23-3	For pagers	—
S-8328BXXMC	—	Yes	100	Yes	—	SOT-23-5	For large load current with shutdown function	Page.14 to 15
S-8328BXXMA	—	Yes	100	—	—	SOT-23-3	For large load current without shutdown function	Page.14 to 15
S-8328BXXUA	—	Yes	100	—	—	SOT-89-3	For large load current without shutdown function	Page.14 to 15
S-8328EXXMC	—	Yes	100	—	Yes	SOT-23-5	For variable output voltage by step-up DC/DC converter with an external resistor	Page.15

# SMALL PACKAGE PWM/PFM CONTROL STEP-UP SWITCHING REGULATOR

## S-8324/8328 Series

### ■ Pin Assignment

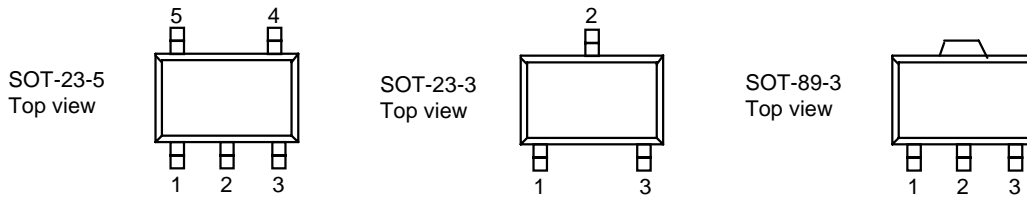


Figure 2

- S-8324AXXMC, S-8328BXXMC  
SOT-23-5

Pin No.	Pin name	Functions
1	ON / $\overline{\text{OFF}}$	Shutdown pin “H”: normal operation (stepping up operation) “L”: stop stepping up (whole circuit stop)
2	$V_{\text{OUT}}$	Output voltage pin and power supply pin
3	—	N.C. (Non Connection)
4	$V_{\text{SS}}$	GND pin
5	CONT	External inductor connection pin (for S-8324 Series)
	EXT	External transistor connection pin (for S-8328 Series)

- S-8324DXXMC, S-8328EXXMC  
SOT-23-5

Pin No.	Pin name	Functions
1	$V_{\text{OUT}}$	Output voltage pin
2	$V_{\text{DD}}$	Power supply pin
3	—	N.C. (Non Connection)
4	$V_{\text{SS}}$	GND pin
5	CONT	External inductor connection pin (for S-8324 Series)
	EXT	External transistor connection pin (for S-8328 Series)

- S-8324AXXMA, S-8324AXXUA, S-8324CXXMA  
S-8328BXXMA, S-8328BXXUA  
SOT-23-3, SOT-89-3

Pin No.	Pin name	Functions
1	$V_{\text{SS}}$	GND pin
2	$V_{\text{OUT}}$	Output voltage pin and power supply pin
3	CONT	External inductor connection pin (for S-8324 Series)
	EXT	External transistor connection pin (for S-8328 Series)

### ■ Absolute Maximum Ratings

Note: A protect circuit for static electricity is built into this IC chip.

However, prevent a charge of static electricity which exceeds the capacity of the protect circuit.

( Unless otherwise specified:  $T_a=25^\circ\text{C}$ )

Parameter	Symbol	Ratings	Unit	
$V_{\text{OUT}}$ pin voltage	$V_{\text{OUT}}$	11	V	
ON/OFF pin voltage	ON/OFF	$V_{\text{SS}} - 0.3$ to 11	V	
CONT pin voltage	$V_{\text{CONT}}$	11	V	
CONT pin current	$I_{\text{CONT}}$	300	mA	
EXT pin voltage	$V_{\text{EXT}}$	$V_{\text{SS}} - 0.3$ to $V_{\text{OUT}}+0.3$	V	
EXT pin current	$I_{\text{EXT}}$	$\pm 50$	mA	
Power dissipation	PD	SOT-89-3	500	mW
		SOT-23-5, SOT-23-3	150	
Operating temperature	$T_{\text{OPR}}$	-40 to +85	$^\circ\text{C}$	
Storage temperature	$T_{\text{STG}}$	-40 to +125	$^\circ\text{C}$	

# SMALL PACKAGE PWM/PFM CONTROL STEP-UP SWITCHING REGULATOR

## S-8324/8328 Series

### Electrical Characteristics

#### 1-1.S-8324AXXMC

(Unless otherwise specified: Ta=25°C)

Parameter	Symbol	Conditions	Min.	Typ.	Max.	Unit	Test circuit	
Output voltage	V <sub>OUT</sub>		S-8324A50MC	4.880	5.000	5.120	V	1
			S-8324A33MC	3.221	3.300	3.379		
			S-8324A30MC	2.928	3.000	3.072		
			S-8324A28MC	2.733	2.800	2.867		
			S-8324A27MC	2.635	2.700	2.765		
			S-8324A25MC	2.440	2.500	2.560		
Input voltage	V <sub>IN</sub>		—	—	9			
Operation start voltage	V <sub>ST1</sub>	I <sub>OUT</sub> =1mA	—	—	0.9			
Oscillation start voltage	V <sub>ST2</sub>	No external parts, voltage applied to V <sub>OUT</sub> CONT pulled up to 5 V by 10kΩ	—	—	0.8		2	
Operation holding voltage	V <sub>HLD</sub>	I <sub>OUT</sub> =1mA, Measured by decreasing V <sub>IN</sub> voltage gradually	0.7	—	—	V	1	
Input current at no load	I <sub>IN</sub>	No load	S-8324A50MC	—	10.5	21.1		—
			S-8324A33MC	—	10.4	20.8		
			S-8324A30MC	—	10.4	20.7		
			S-8324A28MC	—	10.5	21.0		
			S-8324A27MC	—	10.5	21.1		
			S-8324A25MC	—	10.5	21.0		
Current consumption 1	I <sub>SS1</sub>	V <sub>OUT</sub> =output voltage×0.95	S-8324A50MC	—	30.2	50.3	μA	2
			S-8324A33MC	—	19.1	31.8		
			S-8324A30MC	—	17.2	28.7		
			S-8324A28MC	—	16.1	26.8		
			S-8324A27MC	—	15.5	25.9		
			S-8324A25MC	—	14.3	23.9		
Current consumption 2	I <sub>SS2</sub>	V <sub>OUT</sub> =output voltage+0.5	S-8324A50MC	—	3.5	6.9		
			S-8324A33MC	—	3.3	6.5		
			S-8324A30MC	—	3.2	6.4		
			S-8324A28MC	—	3.2	6.4		
			S-8324A27MC	—	3.2	6.4		
			S-8324A25MC	—	3.2	6.3		
Current consumption during shutdown	I <sub>SSS</sub>	shutdown pin=0V	—	—	0.5			
Switching current	I <sub>SW</sub>	V <sub>CONT</sub> =0.4V	S-8324A50MC	114	182	—	mA	—
			S-8324A33MC	78	125	—		
			S-8324A30MC	78	125	—		
			S-8324A28MC	61	98	—		
			S-8324A27MC	61	98	—		
			S-8324A25MC	61	98	—		
Switchin transistor leak current	I <sub>SWQ</sub>	V <sub>OUT</sub> = V <sub>CONT</sub> =10V	—	—	1.0	μA		
Line regulation	ΔV <sub>OUT1</sub>	V <sub>IN</sub> =output voltage×0.4 to ×0.6	—	30	60	mV		
Load regulation	ΔV <sub>OUT2</sub>	I <sub>OUT</sub> =10μA to I <sub>OUT</sub> (below) ×1.25	—	30	60			
Output voltage temperature coefficient	ΔV <sub>OUT</sub> /ΔTa	Ta=-40°C to +85°C	S-8324A50MC	—	±0.25	—	mV/°C	1
			S-8324A33MC	—	±0.17	—		
			S-8324A30MC	—	±0.15	—		
			S-8324A28MC	—	±0.14	—		
			S-8324A27MC	—	±0.14	—		
			S-8324A25MC	—	±0.13	—		
Oscillation frequency	f <sub>osc</sub>	V <sub>OUT</sub> =output voltage×0.95 Measured waveform at CONT pin	42.5	50	57.5	kHz	1	
Max duty ratio	MaxDuty	V <sub>OUT</sub> =output voltage×0.95 Measured waveform at CONT pin	75	83	90	%	1	
PWM/PFM control switch duty ratio	PFMDuty	V <sub>IN</sub> = output voltage - 0.1V No load	5	15	24		1	
Shutdown pin Input voltage (ON/OFF type)	V <sub>SH</sub>	V <sub>OUT</sub> =output voltage×0.95 Measured the oscillation at CONT pin	0.75	—	—	V	2	
	V <sub>SL1</sub>	V <sub>OUT</sub> =output voltage×0.95 When V <sub>OUT</sub> ≥1.5V	—	—	0.3			
	V <sub>SL2</sub>	Judged the stop of oscillation at CONT pin When V <sub>OUT</sub> <1.5V	—	—	0.2			
Soft start time	T <sub>SS</sub>		3.0	6.0	12.0	ms	—	
Efficiency	EFFI		S-8324A50MC	—	87	—	%	1
			S-8324A33MC	—	83	—		
			S-8324A30MC	—	83	—		
			S-8324A28MC	—	79	—		
			S-8324A27MC	—	79	—		
			S-8324A25MC	—	79	—		

External parts used:

- Coil: CD54 (100μH) of Sumida Electric Co., Ltd.
- Diode: MA720 (schottky type) of Matsushita Electronic Components Co., Ltd.
- Capacitor: F93 (16V, 22μF, tantalum type) of Nichicon Corporation)

Applied V<sub>IN</sub>=output voltage×0.6, I<sub>OUT</sub>=output voltage/250Ω

The shutdown pin is connected to V<sub>OUT</sub> pin.

Note 1 : The output voltage specified above is the typical value.

# SMALL PACKAGE PWM/PFM CONTROL STEP-UP SWITCHING REGULATOR

## S-8324/8328 Series

1-2.S-8324AXXMA, S-8324AXXUA, S-8324DXXMC

(Unless otherwise specified: Ta=25°C)

Parameter	Symbol	Conditions	Min.	Typ.	Max.	Unit	Test circuit	
Output voltage	V <sub>OUT</sub>		S-8324X50XX	4.880	5.000	5.120	V	1
			S-8324X33XX	3.221	3.300	3.379		
			S-8324X30XX	2.928	3.000	3.072		
			S-8324X27XX	2.635	2.700	2.765		
			S-8324X25XX	2.440	2.500	2.560		
S-8324X20XX	1.952	2.000	2.048					
Input voltage	V <sub>IN</sub>		—	—	9			
Operation start voltage	V <sub>ST1</sub>	I <sub>OUT</sub> =1mA	—	—	0.9			
Oscillation start voltage	V <sub>ST2</sub>	No external parts, voltage applied to V <sub>OUT</sub> CONT pulled up to 5 V by 10kΩ	—	—	0.8		2	
Operation holding voltage	V <sub>HLD</sub>	I <sub>OUT</sub> =1mA, Measured by decreasing V <sub>IN</sub> voltage gradually	0.7	—	—	V	1	
Input current at no load	I <sub>IN</sub>	No load	S-8324X50XX	—	10.5	21.1		—
			S-8324X33XX	—	10.4	20.8		
			S-8324X30XX	—	10.4	20.7		
			S-8324X27XX	—	10.5	21.1		
			S-8324X25XX	—	10.5	21.0		
S-8324X20XX	—	10.8	21.5					
Current consumption 1	I <sub>SS1</sub>	V <sub>OUT</sub> =output voltage×0.95	S-8324X50XX	—	30.2	50.3	μA	2
			S-8324X33XX	—	19.1	31.8		
			S-8324X30XX	—	17.2	28.7		
			S-8324X27XX	—	15.5	25.9		
			S-8324X25XX	—	14.3	23.9		
S-8324X20XX	—	11.6	19.4					
Current consumption 2	I <sub>SS2</sub>	V <sub>OUT</sub> =output voltage+0.5	S-8324X50XX	—	3.5	6.9		
			S-8324X33XX	—	3.3	6.5		
			S-8324X30XX	—	3.2	6.4		
			S-8324X27XX	—	3.2	6.4		
			S-8324X25XX	—	3.2	6.3		
S-8324X20XX	—	3.1	6.2					
Switching current	I <sub>SW</sub>	V <sub>CONT</sub> =0.4V	S-8324X50XX	114	182	—	mA	—
			S-8324X33XX	78	125	—		
			S-8324X30XX	78	125	—		
			S-8324X27XX	61	98	—		
			S-8324X25XX	61	98	—		
S-8324X20XX	45	71	—					
Switchin transistor leak current	I <sub>SWQ</sub>	V <sub>OUT</sub> = V <sub>CONT</sub> =10V	—	—	1.0	μA		
Line regulation	ΔV <sub>OUT1</sub>	V <sub>IN</sub> = output voltage ×0.4 to ×0.6	—	30	60	mV		
Load regulation	ΔV <sub>OUT2</sub>	I <sub>OUT</sub> =10μA to I <sub>OUT</sub> (below) ×1.25	—	30	60			
Output voltage temperature coefficient	ΔV <sub>OUT</sub> /ΔTa	Ta=-40°C to +85°C	S-8324X50XX	—	±0.25	—	mV/°C	1
			S-8324X33XX	—	±0.17	—		
			S-8324X30XX	—	±0.15	—		
			S-8324X27XX	—	±0.14	—		
			S-8324X25XX	—	±0.13	—		
S-8324X20XX	—	±0.10	—					
Oscillation frequency	fosc	V <sub>OUT</sub> =output voltage×0.95 Measured waveform at CONT pin	42.5	50	57.5	kHz	2	
Max duty ratio	MaxDuty	V <sub>OUT</sub> =output voltage×0.95 Measured waveform at CONT pin	75	83	90	%		
PWM/PFM control switch duty ratio	PFMDuty	V <sub>IN</sub> = output voltage - 0.1V No load	5	15	24		1	
Soft start time	T <sub>SS</sub>		3.0	6.0	12.0	ms	—	
Efficiency	EFFI		S-8324X50XX	—	87	—	%	1
			S-8324X33XX	—	83	—		
			S-8324X30XX	—	83	—		
			S-8324X27XX	—	79	—		
			S-8324X25XX	—	79	—		
S-8324X20XX	—	75	—					

External parts used:

- Coil: CD54 (100μH) of Sumida Electric Co., Ltd.
- Diode: MA720 (schottky type) of Matsushita Electronic Components Co., Ltd.
- Capacitor: F93 (16V, 22μF, tantalum type) of Nichicon Corporation)

Applied V<sub>IN</sub>=output voltage×0.6, I<sub>OUT</sub>=output voltage/250Ω

The V<sub>DD</sub> pin is connected to V<sub>OUT</sub> pin for V<sub>DD</sub>/V<sub>OUT</sub> separate product.

Note 1 : The output voltage specified above is the typical value.

Note 2 : V<sub>DD</sub>/V<sub>OUT</sub> Separate products:

Boot operation is performed from V<sub>DD</sub>=0.8V.

However, 2.0 V or more voltage for V<sub>DD</sub> is recommended to stabilize the output voltage and oscilation frequency.

# SMALL PACKAGE PWM/PFM CONTROL STEP-UP SWITCHING REGULATOR

## S-8324/8328 Series

1-3.S-8324CXXMA

(Unless otherwise specified: Ta=25°C)

Parameter	Symbol	Conditions	Min.	Typ.	Max.	Unit	Test circuit	
Output voltage	V <sub>OUT</sub>		S-8324C30MA	2.928	3.000	3.072	V	1
			S-8324C27MA	2.635	2.700	2.765		
			S-8324C25MA	2.440	2.500	2.560		
Input voltage	V <sub>IN</sub>		—	—	9			
Operation start voltage	V <sub>ST1</sub>	I <sub>OUT</sub> =1mA	—	—	0.9			
Oscillation start voltage	V <sub>ST2</sub>	No external parts, voltage applied to V <sub>OUT</sub> CONT pulled up to 5 V by 10kΩ	—	—	0.8		2	
Operation holding voltage	V <sub>HLD</sub>	I <sub>OUT</sub> =1mA, Measured by decreasing V <sub>IN</sub> voltage gradually	0.7	—	—	V	1	
Input current at no load	I <sub>IN</sub>	No load	S-8324C30MA	—	9.6	19.1		—
			S-8324C27MA	—	9.5	19.1		
			S-8324C25MA	—	9.7	19.3		
Current consumption 1	I <sub>SS1</sub>	V <sub>OUT</sub> =output voltage×0.95	S-8324C30MA	—	11.6	19.3	μA	2
			S-8324C27MA	—	10.5	17.5		
			S-8324C25MA	—	9.8	16.3		
Current consumption 2	I <sub>SS2</sub>	V <sub>OUT</sub> =output voltage+0.5	S-8324C30MA	—	3.0	5.9		
			S-8324C27MA	—	2.9	5.8		
			S-8324C25MA	—	2.9	5.8		
Switching current	I <sub>SW</sub>	V <sub>CONT</sub> =0.4V	S-8324C30MA	78	125	—	mA	—
			S-8324C27MA	61	98	—		
			S-8324C25MA	61	98	—		
Switchin transistor leak current	I <sub>SWQ</sub>	V <sub>OUT</sub> = V <sub>CONT</sub> =10V	—	—	1.0	μA		
Line regulation	ΔV <sub>OUT1</sub>	V <sub>IN</sub> =output voltage×0.4 to ×0.6	—	30	60	mV		
Load regulation	ΔV <sub>OUT2</sub>	I <sub>OUT</sub> =10μA to I <sub>OUT</sub> (below) ×1.25	—	30	60			
Output voltage temperature coefficient	ΔV <sub>OUT</sub> /ΔTa	Ta=-40°C to +85°C	S-8324C30MA	—	±0.15	—	mV/°C	1
			S-8324C27MA	—	±0.14	—		
			S-8324C25MA	—	±0.13	—		
Oscillation frequency	f <sub>osc</sub>	V <sub>OUT</sub> =output voltage×0.95 Measured waveform at CONT pin	25	30	35	kHz	2	
Max duty ratio	MaxDuty	V <sub>OUT</sub> =output voltage×0.95 Measured waveform at CONT pin	75	83	90	%	1	
PWM/PFM control switch duty ratio	PFMDuty	V <sub>IN</sub> = output voltage - 0.1V No load	5	15	24			
Soft start time	T <sub>SS</sub>		3.0	6.0	12.0	ms	—	
Efficiency	EFFI		S-8324C30MA	—	81	—	%	1
			S-8324C27MA	—	77	—		
			S-8324C25MA	—	77	—		

External parts used:

- Coil: CD54 (100μH) of Sumida Electric Co., Ltd.
- Diode: MA720 (schottky type) of Matsushita Electronic Components Co., Ltd.
- Capacitor: F93 (16V, 22μF, tantalum type) of Nichicon Corporation)

Applied V<sub>IN</sub>=output voltage×0.6, I<sub>OUT</sub>=output voltage/250Ω

Note 1 : The output voltage specified above is the typical value.

# SMALL PACKAGE PWM/PFM CONTROL STEP-UP SWITCHING REGULATOR

## S-8324/8328 Series

2-1.S-8328BXXMC

(Unless otherwise specified: Ta=25°C)

Parameter	Symbol	Conditions	Min.	Typ.	Max.	Unit	Test circuit	
Output voltage	V <sub>OUT</sub>		S-8328B52MC	5.075	5.200	5.325	V	3
			S-8328B50MC	4.880	5.000	5.120		
			S-8328B38MC	3.709	3.800	3.891		
			S-8328B36MC	3.514	3.600	3.686		
			S-8328B33MC	3.221	3.300	3.379		
			S-8328B30MC	2.928	3.000	3.072		
			S-8328B27MC	2.635	2.700	2.765		
		S-8328B25MC	2.440	2.500	2.560			
Input voltage	V <sub>IN</sub>		—	—	9			
Operation start voltage	V <sub>ST1</sub>	I <sub>OUT</sub> =1mA	—	—	0.9			
Oscillation start voltage	V <sub>ST2</sub>	No external parts, voltage applied to V <sub>OUT</sub>	—	—	0.8		4	
Operation holding voltage	V <sub>HLD</sub>	I <sub>OUT</sub> =1mA, Measured by decreasing V <sub>IN</sub> voltage gradually	0.7	—	—	V	3	
Current consumption 1	I <sub>SS1</sub>	V <sub>OUT</sub> =output voltage×0.95	S-8328B52MC	—	39.3	65.5	μA	4
			S-8328B50MC	—	37.6	62.6		
			S-8328B38MC	—	27.6	46.0		
			S-8328B36MC	—	26.0	43.3		
			S-8328B33MC	—	23.7	39.5		
			S-8328B30MC	—	21.4	35.7		
			S-8328B27MC	—	19.2	32.0		
		S-8328B25MC	—	17.8	29.7			
Current consumption 2	I <sub>SS2</sub>	V <sub>OUT</sub> =output voltage+0.5	S-8328B52MC	—	4.2	8.3	μA	4
			S-8328B50MC	—	4.2	8.3		
			S-8328B38MC	—	4.0	8.0		
			S-8328B36MC	—	4.0	7.9		
			S-8328B33MC	—	4.0	7.9		
			S-8328B30MC	—	3.9	7.8		
			S-8328B27MC	—	3.9	7.7		
		S-8328B25MC	—	3.9	7.7			
shutdown current	I <sub>SSS</sub>	shutdown pin=0V	—	—	0.5			
EXT pin output current	I <sub>EXTH</sub>	V <sub>CONT</sub> =-0.4V	S-8328B52MC	-5.3	-8.0	—	mA	—
			S-8328B50MC	-5.3	-8.0	—		
			S-8328B38MC	-3.5	-5.3	—		
			S-8328B36MC	-3.5	-5.3	—		
			S-8328B33MC	-3.5	-5.3	—		
			S-8328B30MC	-3.5	-5.3	—		
			S-8328B27MC	-2.7	-4.0	—		
			S-8328B25MC	-2.7	-4.0	—		
	I <sub>EXTL</sub>	V <sub>CONT</sub> =0.4V	S-8328B52MC	10.7	16.0	—		
			S-8328B50MC	10.7	16.0	—		
			S-8328B38MC	7.0	10.5	—		
			S-8328B36MC	7.0	10.5	—		
			S-8328B33MC	7.0	10.5	—		
			S-8328B30MC	7.0	10.5	—		
S-8328B27MC			5.3	8.0	—			
		S-8328B25MC	5.3	8.0	—			
Line regulation	ΔV <sub>OUT1</sub>	V <sub>IN</sub> =output voltage×0.4 to ×0.6	—	30	60	mV		
Load regulation	ΔV <sub>OUT2</sub>	I <sub>OUT</sub> =10μA to I <sub>OUT</sub> (below)×1.25	—	30	60			
Output voltage temperature coefficient	ΔV <sub>OUT</sub> /ΔTa	Ta=-40°C to +85°C	S-8328B52MC	—	±0.26	—	mV/°C	3
			S-8328B50MC	—	±0.25	—		
			S-8328B38MC	—	±0.19	—		
			S-8328B36MC	—	±0.18	—		
			S-8328B33MC	—	±0.17	—		
			S-8328B30MC	—	±0.15	—		
			S-8328B27MC	—	±0.14	—		
		S-8328B25MC	—	±0.13	—			
Oscillation frequency	f <sub>osc</sub>	V <sub>OUT</sub> =output voltage×0.95 Measured waveform at EXT pin	85	100	115	kHz	4	
Max. duty ratio	MaxDuty	V <sub>OUT</sub> =output voltage×0.95 Measured waveform at EXT pin	75	83	90	%		
PWM/PFM control switch duty ratio	PFMDuty	V <sub>IN</sub> = output voltage - 0.1V No load	5	15	24		3	
Shutdown pin Input voltage (ON/OFF type)	V <sub>SH</sub>	V <sub>OUT</sub> =output voltage×0.95 Measured the oscillation at CONT pin	0.75	—	—	V	4	
	V <sub>SL1</sub>	V <sub>OUT</sub> =output voltage×0.95	—	—	0.3			
	V <sub>SL2</sub>	Judged the stop of oscillation at CONT pin	—	—	0.2			
Soft start time	T <sub>SS</sub>		3.0	6.0	12.0	ms	—	
Efficiency	EFFI		S-8328B52MC	—	88	—	%	3
			S-8328B50MC	—	88	—		
			S-8328B38MC	—	84	—		
			S-8328B36MC	—	84	—		
			S-8328B33MC	—	84	—		
			S-8328B30MC	—	84	—		
			S-8328B27MC	—	80	—		
		S-8328B25MC	—	80	—			

External parts used:

- Coil: CD54 (47μH) of Sumida Electric Co., Ltd.
- Diode: MA720 (schottky type) of Matsushita Electronic Components Co., Ltd.
- Capacitor: F93 (16V, 47μF, tantalum type) of Nichicon Corporation)
- Transistor: 2SD1628G of Sanyo Electronics
- Base resistor (Rb): 1.0KΩ
- Base capacitor (Cb): 2200pF (ceramic)

Applied V<sub>IN</sub>=output voltage×0.6, I<sub>OUT</sub>=output voltage/50Ω  
The shutdown pin is connected to V<sub>OUT</sub> pin.

Note 1 : The output voltage specified above is the typical value.



# SMALL PACKAGE PWM/PFM CONTROL STEP-UP SWITCHING REGULATOR

## S-8324/8328 Series

2-2. S-8328BXXMA, S-8328BXXUA, S-8328EXXMC

(Unless otherwise specified: Ta=25°C)

Parameter	Symbol	Conditions	Min.	Typ.	Max.	Unit	Test circuit	
Output voltage	V <sub>OUT</sub>		S-8328X50XX	4.880	5.000	5.120	V	3
			S-8328X33XX	3.221	3.300	3.379		
			S-8328X30XX	2.928	3.000	3.072		
			S-8328X27XX	2.635	2.700	2.765		
			S-8328X25XX	2.440	2.500	2.560		
			S-8328X20XX	1.952	2.000	2.048		
Input voltage	V <sub>IN</sub>		—	—	9			
Operation start voltage	V <sub>ST1</sub>	I <sub>OUT</sub> =1mA	—	—	0.9			
Oscillation start voltage	V <sub>ST2</sub>	No external parts, voltage applied to V <sub>OUT</sub>	—	—	0.8		4	
Operation holding voltage	V <sub>HLD</sub>	I <sub>OUT</sub> =1mA, Measured by decreasing V <sub>IN</sub> voltage gradually	0.7	—	—	V	3	
Current consumption 1	I <sub>SS1</sub>	V <sub>OUT</sub> =output voltage×0.95	S-8328X50XX	—	37.6	62.6	μA	4
			S-8328X33XX	—	23.7	39.5		
			S-8328X30XX	—	21.4	35.7		
			S-8328X27XX	—	19.2	32.0		
			S-8328X25XX	—	17.8	29.7		
			S-8328X20XX	—	14.5	24.1		
Current consumption 2	I <sub>SS2</sub>	V <sub>OUT</sub> =output voltage+0.5	S-8328X50XX	—	4.2	8.3	μA	4
			S-8328X33XX	—	4.0	7.9		
			S-8328X30XX	—	3.9	7.8		
			S-8328X27XX	—	3.9	7.7		
			S-8328X25XX	—	3.9	7.7		
			S-8328X20XX	—	3.8	7.6		
EXT pin output current	I <sub>EXTH</sub>	V <sub>CONT</sub> =-0.4V	S-8328X50XX	-5.3	-8.0	—	mA	—
			S-8328X33XX	-3.5	-5.3	—		
			S-8328X30XX	-3.5	-5.3	—		
			S-8328X27XX	-2.7	-4.0	—		
			S-8328X25XX	-2.7	-4.0	—		
			S-8328X20XX	-1.9	-2.9	—		
	I <sub>EXTL</sub>	V <sub>CONT</sub> =0.4V	S-8328X50XX	10.7	16.0	—		
			S-8328X33XX	7.0	10.5	—		
			S-8328X30XX	7.0	10.5	—		
			S-8328X27XX	5.3	8.0	—		
			S-8328X25XX	5.3	8.0	—		
			S-8328X20XX	3.8	5.7	—		
Line regulation	ΔV <sub>OUT1</sub>	V <sub>IN</sub> =output voltage×0.4 to ×0.6	—	30	60	mV	3	
Load regulation	ΔV <sub>OUT2</sub>	I <sub>OUT</sub> =10μA to I <sub>OUT</sub> (below) ×1.25	—	30	60	mV		
Output voltage temperature coefficient	ΔV <sub>OUT</sub> /ΔTa	Ta=-40°C to +85°C	S-8328X50XX	—	±0.25	—	mV/°C	3
			S-8328X33XX	—	±0.17	—		
			S-8328X30XX	—	±0.15	—		
			S-8328X27XX	—	±0.14	—		
			S-8328X25XX	—	±0.13	—		
			S-8328X20XX	—	±0.10	—		
Oscillation frequency	f <sub>osc</sub>	V <sub>OUT</sub> =output voltage×0.95 Measured waveform at EXT pin	85	100	115	kHz	4	
Max. duty ratio	MaxDuty	V <sub>OUT</sub> =output voltage×0.95 Measured waveform at EXT pin	75	83	90	%		
PWM/PFM control switch duty ratio	PFMDuty	V <sub>IN</sub> = output voltage - 0.1V No load	5	15	24	%	3	
Soft start time	T <sub>SS</sub>		3.0	6.0	12.0	ms	—	
Efficiency	EFFI		S-8328X50XX	—	88	—	%	3
			S-8328X33XX	—	84	—		
			S-8328X30XX	—	84	—		
			S-8328X27XX	—	80	—		
			S-8328X25XX	—	80	—		
			S-8328X20XX	—	76	—		

External parts used:

- Coil: CD54 (47μH) of Sumida Electric Co., Ltd.
- Diode: MA720 (schottky type) of Matsushita Electronic Components Co., Ltd.
- Capacitor: F93 (16V, 47μF, tantalum type) of Nichicon Corporation)
- Transistor: 2SD1628G of Sanyo Electronics
- Base resistor (Rb): 1.0KΩ
- Base capacitor (Cb): 2200pF (ceramic)

Applied V<sub>IN</sub>=output voltage×0.6, I<sub>OUT</sub>=output voltage/50Ω  
The V<sub>DD</sub> pin is connected to V<sub>OUT</sub> pin for V<sub>DD</sub>/V<sub>OUT</sub> separate product.

- Note 1 : The output voltage specified above is the typical value.  
Note 2 : V<sub>DD</sub>/V<sub>OUT</sub> Separate products:  
Boot operation is performed from V<sub>DD</sub>=0.8V.  
However, 2.0 V or more voltage for V<sub>DD</sub> is recommended to stabilize the output voltage and oscillation frequency.

■ **Test Circuits**

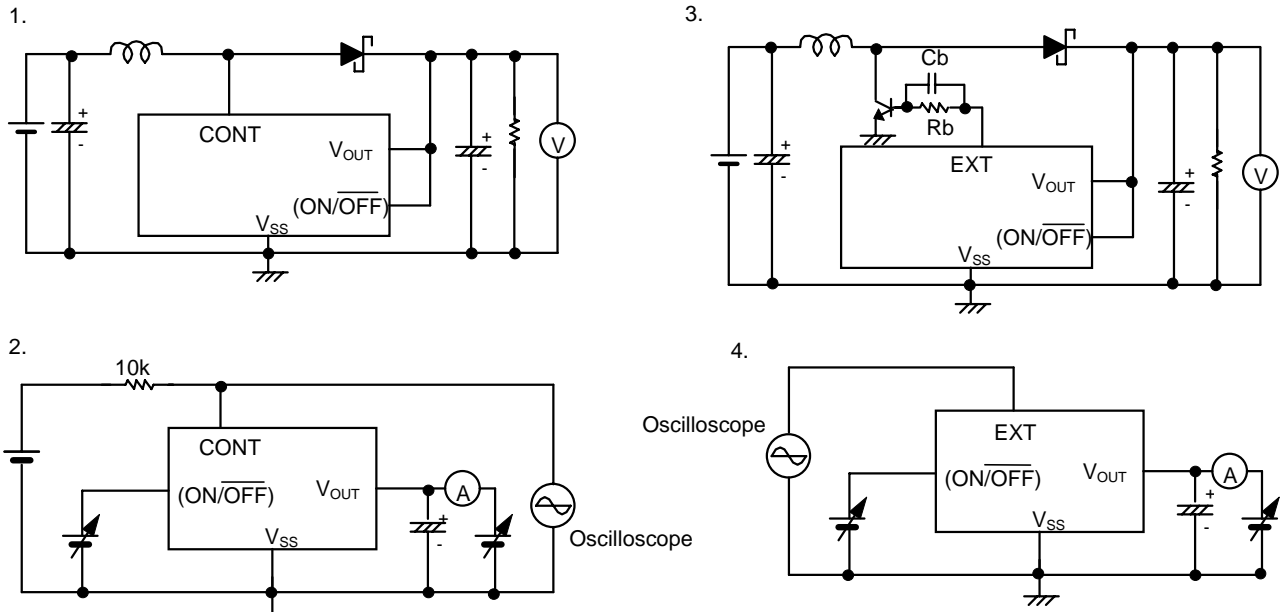


Figure 3

■ **Operation**

1. Step-Up DC/DC Converter

The S-8324/8328 series is a DC/DC converter using a pulse frequency modulation method (PFM) or a pulse width modulation method (PWM) which are switched automatically according to the load current with a low current consumption.

Especially in the region of 100μA output load current, a high-efficiency DC/DC converter is obtained.

In conventional fixed-duty type PFM DC/DC converters, pulses are skipped at low output load current, causing fluctuation in ripple frequency of the output voltage, with the result of increase in ripple voltage.

The S-8324/8328 series operates with the PWM control which changes the pulse width duty from 15% to 83% in the region of large output load current.

The ripple voltage generated from switching can be removed easily through the filter because the switching frequency is constant.

The S-8324/8328 series operates with the PFM control which skips the pulse of the duty 15% pulth width and output that pulse to the switching transistor according to the load current.

From the above operation, the self current consumption is reduced from the blocking oscillation of the oscillation circuit, and a fall of efficiency can be protected in small load.

The switching point between PWM and PFM control differs according to the external elements (coil, diode and other), input voltage and output voltage.

See reference data about this.

# SMALL PACKAGE PWM/PFM CONTROL STEP-UP SWITCHING REGULATOR

## S-8324/8328 Series

Shutdown pin: Stops or starts step-up operation.

(Only for SOT-23-5 package products of A and B Series.)

Turning the shutdown pin low stops operation of all the internal circuits and reduces current consumption significantly. Do NOT use the shutdown pin in floating state because it has a structure shown in Figure 4 and is not pulled up or pulled down internally. Do NOT apply voltage of between 0.3 V and 0.75 V to the shutdown pin because applying such voltage increases the current consumption. If the shutdown pin is not used, connect it to V<sub>OUT</sub> pin.

The shutdown pin doesn't have hysteresis.

Shutdown pin	CR oscillation circuit	Output voltage
"H"	Operation	Fixed
"L"	Stop	~V <sub>IN</sub> *

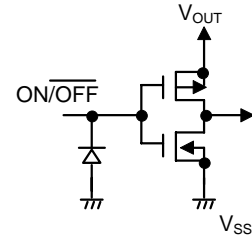


Figure 4

\* Voltage obtained by extracting the voltage drop due to DC resistance of the inductor and the diode forward voltage from V<sub>IN</sub>.

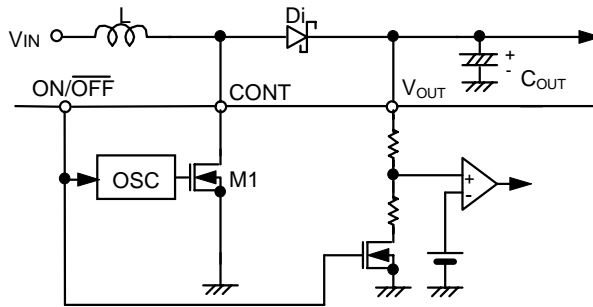


Figure 5

The following are basic equations [(1) through (7)] of the step-up switching regulator (see Figure 5.)

Voltage at CONT pin the moment M1 is turned ON (current I<sub>L</sub> flowing through L is zero):

$$V_A = V_S \quad \dots\dots\dots (1)$$

(V<sub>S</sub>: Non-saturated voltage of M1)

The change in I<sub>L</sub> over time:

$$\frac{dI_L}{dt} = \frac{V_L}{L} = \frac{V_{IN} - V_S}{L} \quad \dots\dots\dots (2)$$

Integration of the above equation (I<sub>L</sub>):

$$I_L = \left( \frac{V_{IN} - V_S}{L} \right) \cdot t \quad \dots\dots\dots (3)$$

I<sub>L</sub> flows while M1 is turned ON (t<sub>ON</sub>). The time of t<sub>ON</sub> is determined by the oscillation frequency of the OSC.

The peak current (I<sub>PK</sub>) after ton:

$$I_{PK} = \left( \frac{V_{IN} - V_S}{L} \right) \cdot t_{ON} \quad \dots\dots\dots (4)$$

The energy stored in L is represented with  $\frac{1}{2} L (I_{PK})^2$ .

When M1 is turned OFF ( $t_{OFF}$ ), the energy stored in L is transmitted through a diode to the output capacitor. Then reverse voltage ( $V_L$ ) is generated.

$$V_L = (V_{OUT} + V_D) - V_{IN} \dots \dots \dots (5)$$

( $V_D$  : Diode forward voltage)

The voltage at CONT pin rises only by the voltage corresponding to  $V_{OUT} + V_D$ .

The change in the current flowing through the diode into  $V_{OUT}$  during  $t_{OFF}$ :

$$\frac{dI_L}{dt} = \frac{V_L}{L} = \frac{V_{OUT} + V_D - V_{IN}}{L} \dots \dots \dots (6)$$

Integration of the above equation is as follows:

$$I_L = I_{PK} - \left( \frac{V_{OUT} + V_D - V_{IN}}{L} \right) \cdot t \dots \dots \dots (7)$$

During  $t_{ON}$ , the energy is stored in L and is not transmitted to  $V_{OUT}$ . When receiving output current ( $I_{OUT}$ ) from  $V_{OUT}$ , the energy of the capacitor ( $C_{OUT}$ ) is consumed. As a result, the pin voltage of  $C_{OUT}$  is reduced, and goes to the lowest level after M1 is turned ON ( $t_{ON}$ ). When M1 is turned OFF, the energy stored in L is transmitted through the diode to  $C_{OUT}$ , and the voltage of  $C_{OUT}$  rises drastically.  $V_{OUT}$  is a time function that indicates the maximum value (ripple voltage:  $V_{P-P}$ ) when the current flowing through the diode into  $V_{OUT}$  and load current ( $I_{OUT}$ ) match.

Next, the ripple voltage is found out as follows:

$I_{OUT}$  vs  $t_1$  (time) from when M1 is turned OFF ( after  $t_{ON}$ ) to when  $V_{OUT}$  reaches the maximum level:

$$I_{OUT} = I_{PK} - \left( \frac{V_{OUT} + V_D - V_{IN}}{L} \right) \cdot t_1 \dots \dots \dots (8)$$

$$\therefore t_1 = (I_{PK} - I_{OUT}) \cdot \left( \frac{L}{V_{OUT} + V_D - V_{IN}} \right) \dots \dots \dots (9)$$

After ( $t_{OFF}$ ),  $I_L = 0$  (when the energy of the inductor is completely transmitted). Based on equation (7),

$$\left( \frac{L}{V_{OUT} + V_D - V_{IN}} \right) = \frac{t_{OFF}}{I_{PK}} \dots \dots \dots (10)$$

When substituting equation (10) for equation (9),

$$t_1 = t_{OFF} \cdot \left( \frac{I_{OUT}}{I_{PK}} \right) \cdot t_{OFF} \dots \dots \dots (11)$$

Electric charge  $\Delta Q_1$  which is charged in  $C_{OUT}$  during  $t_1$ :

$$\begin{aligned} \Delta Q_1 &= \int_0^{t_1} I dt = I_{PK} \cdot \int_0^{t_1} dt - \frac{V_{OUT} + V_D - V_{IN}}{L} \cdot \int_0^{t_1} t dt \\ &= I_{PK} \cdot t_1 - \frac{V_{OUT} + V_D - V_{IN}}{L} \cdot \frac{1}{2} t_1^2 \dots \dots \dots (12) \end{aligned}$$

When substituting equation (12) for equation (9):

$$\Delta Q_1 = I_{PK} - \frac{1}{2} (I_{PK} - I_{OUT}) \cdot t_1 = \frac{I_{PK} + I_{OUT}}{2} \cdot t_1 \dots \dots \dots (13)$$

A rise in voltage ( $V_{P-P}$ ) due to  $\Delta Q_1$ :

$$V_{P-P} = \frac{\Delta Q_1}{C_{OUT}} = \frac{1}{C_{OUT}} \cdot \left( \frac{I_{PK} + I_{OUT}}{2} \right) \cdot t_1 \dots \dots \dots (14)$$

When taking into consideration  $I_{OUT}$  to be consumed during  $t_1$  and ESR (Electric Series Resistance) of  $C_{OUT}$ , namely  $R_{ESR}$ :

$$V_{P-P} = \frac{\Delta Q_1}{C_{OUT}} = \frac{1}{C_{OUT}} \cdot \left( \frac{I_{PK} + I_{OUT}}{2} \right) \cdot t_1 + \left( \frac{I_{PK} + I_{OUT}}{2} \right) \cdot R_{ESR} - \frac{I_{OUT} \cdot t_1}{C_{OUT}} \dots \dots \dots (15)$$

**SMALL PACKAGE PWM/PFM CONTROL STEP-UP SWITCHING REGULATOR**  
**S-8324/8328 Series**

---

When substituting equation (11) for equation (15):

$$V_{P-P} = \frac{(I_{PK} - I_{OUT})^2}{2I_{PK}} \cdot \frac{t_{OFF}}{C_{OUT}} + \left( \frac{I_{PK} + I_{OUT}}{2} \right) \cdot R_{ESR} \dots\dots\dots(16)$$

Therefore to reduce the ripple voltage, it is important that the capacitor connected to the output pin has a large capacity and a small ESR.

■ **External Parts Selection for DC-DC Converter**

The relationship between major characteristics of the step-up circuit and characteristics parameters of the external parts are shown in Figure 6.

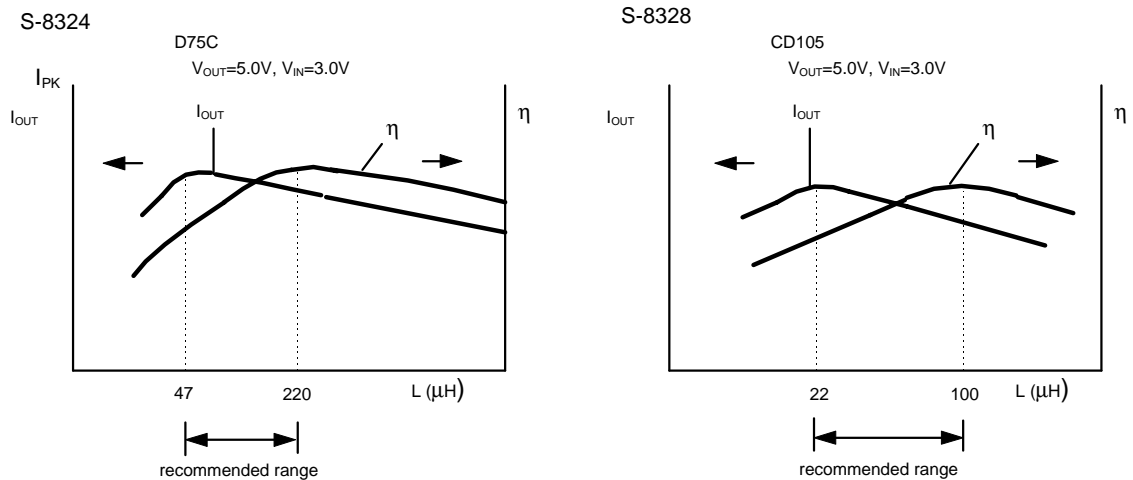
for large output current?	for high efficiency?		for small ripple voltage
	operation efficiency	stand-by efficiency	
small inductance	large inductance		
small DC resistance of inductor			
			large output capacitance
external switching transistor (small ON resistance)	built-in switching transistor		
small resistance of external resistor Rb when an external switching transistor is used	large resistance of external resistor Rb when an external switching transistor is used.		

**Figure 6 Relationship between major characteristics of the step-up circuit and external parts**

1. Inductor

An inductance has strong influence on max. output current  $I_{OUT}$  and efficiency  $\eta$ .

Figure 7 shows  $I_{OUT}$   $\eta$  characteristics for inductance of S-8324 and S-8328.



**Figure 7**

The peak current  $I_{PK}$  increases by decreasing  $L$  and  $I_{OUT}$  is at max. value at  $L$  value.

Further decreasing  $L$  decreases  $I_{OUT}$  due to the lack of the current driving capacity of the switching transistor.

The loss of  $I_{PK}$  by the switching transistor decreases by increasing  $L$  and the efficiency becomes max. at  $L$  value.

Further increasing  $L$  decreases efficiency due to the loss of the DC resistance of the coil.

47 to 220  $\mu$ H inductor for S-8324 and 22 to 100  $\mu$ H inductor for S-8328 are recommended.

Choose a value for  $L$  by referring to the reference data because the maximum output current is due to the input voltage in an actual case.

Choose an inductor so that the peak current  $I_{PK}$  does not exceed the allowable current.

Exceeding the allowable current of the inductor causes magnetic saturation, remarkable low efficiency and destruction of the IC chip due to a large current.

The peak current  $I_{PK}$  in uncontinuous mode is calculated from the following formula:

$$I_{PK} = \sqrt{\frac{2 I_{OUT} (V_{OUT} + V_D - V_{IN})}{f_{OSC} \cdot L}} \quad (A) \quad (17)$$

$f_{osc}$ : oscillation frequency

$V_D \cong 0.4V$

For instance, when you choose 100  $\mu$ H at  $f_{osc}=50$  kHz for  $L$  using the S-8324A 50MC at the following conditions,  $I_{PK}$  is calculated to 170 mA from the (17) formula.

- Input voltage  $V_{IN}=3$  V
- Output voltage  $V_{OUT}=5$  V
- Load current  $I_{OUT}=30$  mA

The switching current limit circuit is not built into this IC chip.

$I_{PK}$  current must be 500 mA or less.

# SMALL PACKAGE PWM/PFM CONTROL STEP-UP SWITCHING REGULATOR S-8324/8328 Series

## 2. Diode

Use an external diode that meets the following requirements:

- Low forward voltage ( $V_F < 0.3V$ )
- High switching speed (500 ns max.)
- Reverse voltage:  $V_{OUT} + V_F$  or more
- Rated current:  $I_{PK}$  or more

## 3. Capacitors ( $C_{IN}$ , $C_{OUT}$ )

A capacitor at the input side ( $C_{IN}$ ) improves the efficiency by reducing the power impedance and stabilizing the input current. Select a  $C_{IN}$  value according to the impedance of the power supply used. The capacitor value should be around 10  $\mu F$ .

A capacitor at the output side ( $C_{OUT}$ ) is used for smoothing the ripple voltage. Therefore select a capacitor with a small ESR (Electric Series Resistance) and a large capacitance. The capacitor value should be 10  $\mu F$  min. A tantalum electrolytic capacitor and an organic semiconductor capacitor are especially recommended because of their superior low-temperature characteristic and leakage current characteristic.

## 4. External Transistor (S-8328 Series)

For the S-8328 Series, connecting an external transistor increases the output current. A bipolar (NPN) transistor or an enhancement (N-channel) MOS FET transistor can be used as external transistor.

### 4.1. Bipolar (NPN) transistor

A circuit example using a bipolar transistor (NPN), Sanyo 2SD1628G ( $h_{FE} = 280$  to 560) is shown in Figure 11. The  $h_{FE}$  value and the  $R_b$  value determine the driving capacity to increase the output current using a bipolar transistor. A peripheral circuit example of the transistor is shown in Figure 8.

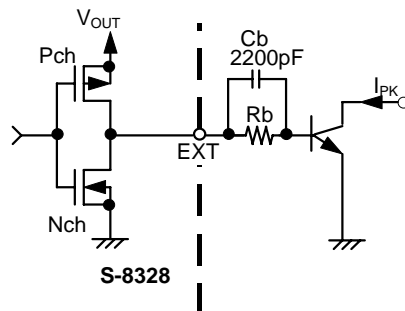


Figure 8 External transistor

1 k $\Omega$  is recommended for  $R_b$ .  $R_b$  is calculated from the following formula:

$$R_b = \frac{V_{OUT} - 0.7}{I_b} - \frac{0.4}{|I_{EXT}|}$$

$$I_b = I_{PK} / h_{FE}$$

A small  $R_b$  increases output current, however, the efficiency decreases.

The current flows pulsating and there is voltage drop due to wiring resistance in an actual circuit, therefore optimum  $R_b$  value should be determined by experiment.

A speed-up capacitor connected in parallel with  $R_b$  resistance as shown in Figure 9 decreases the switching loss and improves the efficiency.

$C_b$  is calculated from the following formula:

$$C_b \leq \frac{1}{2\pi \times R_b \times f_{OSC} \times 0.7}$$

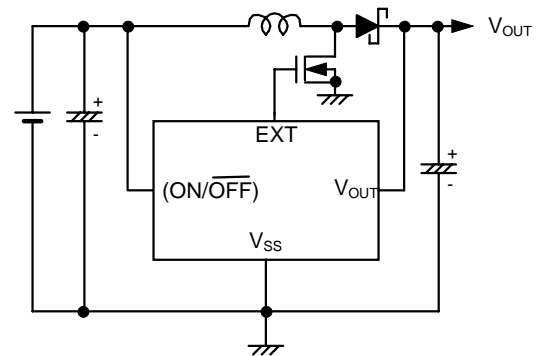
# SMALL PACKAGE PWM/PFM CONTROL STEP-UP SWITCHING REGULATOR S-8324/8328 Series

## 4.2. Enhancement MOS FET Type

Figure 9 is a circuit example using NEC 2SK1959 MOS FET transistor (N-channel).

For a MOS FET, an N-channel power MOS FET should be used. In particular the EXT pin of the S-8328 can drive a MOS FET with a gate capacity of around 1000 pF. Because the gate voltage and current of the external power MOS FET are supplied from the stepped out output voltage  $V_{OUT}$ , the MOS FET is driven more effectively.

Since the ON resistor of the MOS FET might affect the output amperage as well as the efficiency, the threshold voltage should be low. When the output voltage is as low as 2.0V the same as in the S-8328E20, the circuit operates only when the MOS FET has the threshold voltage lower than 2.0V.



**Figure 9** Circuit example using 2SK1959

## 5. Others (S-8324D and S-8328E only)

The S-8324D and S-8328E are applicable to the following uses because the power pin for IC chip and Vout pin for output voltage are separated:

- ① When changing the output voltage with an external resistance.
- ② When outputting the high voltage such as +12 V or 15 V.
- ③ When making the step-down DC/DC converter. (S-8324D only)
- ④ When making the inverted DC/DC converter.

Choose the products in the following table according to applications for ① to ③.

Use	Step-up					Step-down			
	$2V \leq V_{CC} < 3V$	$3V \leq V_{CC} < 5V$	$5V \leq V_{CC} < 9V$	$9V \leq V_{CC}$	Ref. circuit	$2V \leq V_{CC} < 3V$	$3V \leq V_{CC} < 5V$	$5V \leq V_{CC} < 9V$	Ref. circuit
S-8324D20	○	—	—	—	Std. circuit (5)	○	—	—	Appl. circuit 3
S-8324D30	—	○	—	—	Std. circuit (5)	—	○	—	Appl. circuit 3
S-8324D50	—	—	○	—	Std. circuit (5)	—	—	○	Appl. circuit 3
S-8328E20	○	○	—	—	Std. circuit (6)	—	—	—	—
S-8328E50	—	—	○	○	Std. circuit (6)	—	—	—	—
Connection to $V_{DD}$ pin	$V_{IN}$ or $V_{CC}$	$V_{IN}$ or $V_{CC}$	$V_{IN}$ or $V_{CC}$	$V_{IN}$	—	$V_{IN}$	$V_{IN}$	$V_{IN}$	—

The operational precautions are follows:

- I. This IC starts to oscillate and to step up operation at  $V_{DD}=0.9$  V, but frequency of oscillator doesn't stabilize. Input the voltage from 2 V to 9 V for  $V_{DD}$  pin to get the stabilized output voltage and oscillation frequency. The input voltage from 2 V to 9 V for  $V_{DD}$  pin allows the connection of  $V_{DD}$  pin to both input power pin  $V_{IN}$  and output power pin  $V_{out}$ .
- II. Choose external resistors  $R_A$  and  $R_B$  not to affect to the output voltage with the consideration of the impedance between  $V_{OUT}$  and  $V_{SS}$  pins in the IC chip. Internal resistance between  $V_{OUT}$  and  $V_{SS}$  pins are as follows:
  - ① S-8324D20 and S-8328E20 : 3.0 M $\Omega$  to 19.6 M $\Omega$
  - ② S-8324D30 : 3.3 M $\Omega$  to 22.6 M $\Omega$
  - ③ S-8324D50 and S-8328E50 : 2.1 M $\Omega$  to 19.1 M $\Omega$
- III. Attach the capacitor " $C_C$ " in parallel to  $R_A$  resistance when the oscillation of the output voltage occurs.

Calculate " $C_C$ " from the following formula:

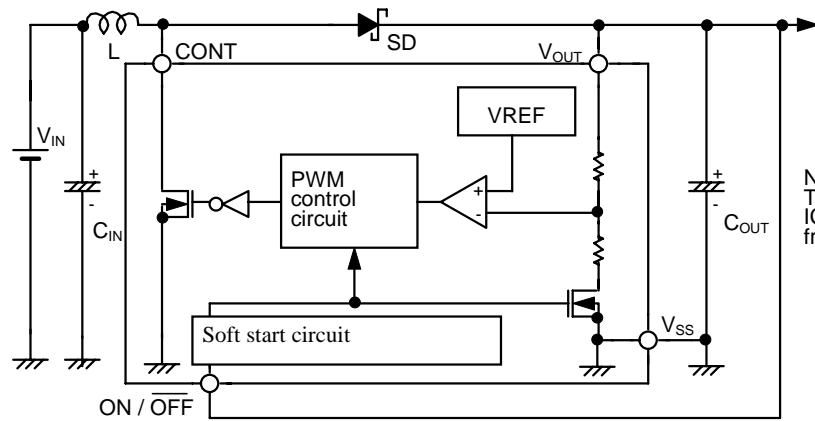
$$C_C (F) = \frac{1}{2 \cdot \pi \cdot R_A \cdot 20kHz}$$



**SMALL PACKAGE PWM/PFM CONTROL STEP-UP SWITCHING REGULATOR**  
**S-8324/8328 Series**

■ **Standard Circuits**

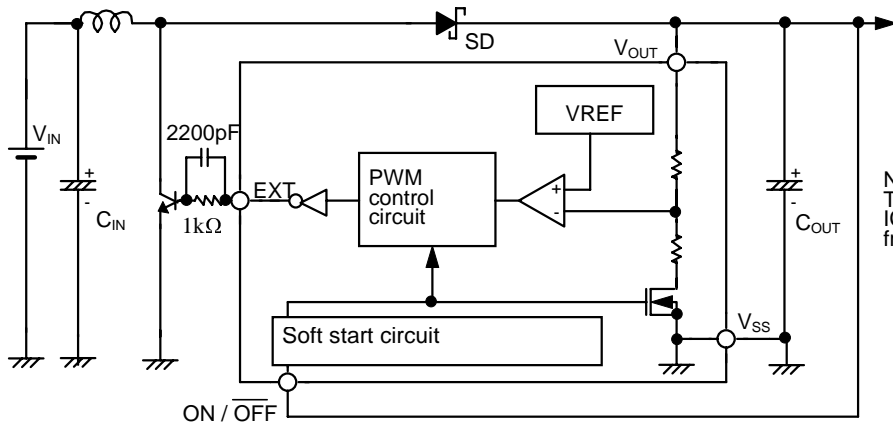
(1) S-8324AXXMC



Note:  
The power supply for IC chip is supplied from Vout pin.

Figure 10

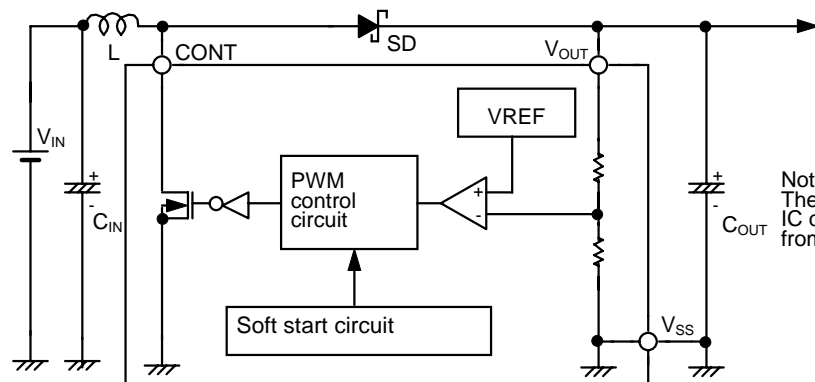
(2) S-8328BXXMC



Note:  
The power supply for IC chip is supplied from Vout pin.

Figure 11

(3) S-8324AXXMA  
 S-8324AXXUA  
 S-8324CXXMA

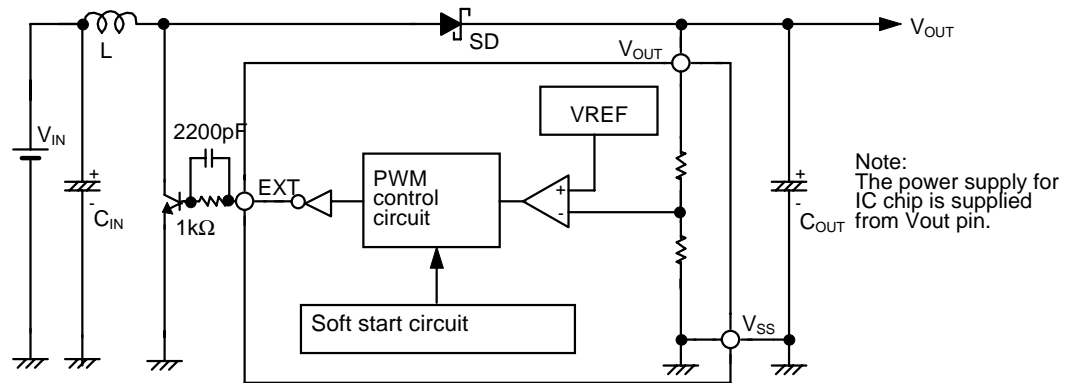


Note:  
The power supply for IC chip is supplied from Vout pin.

Figure 12

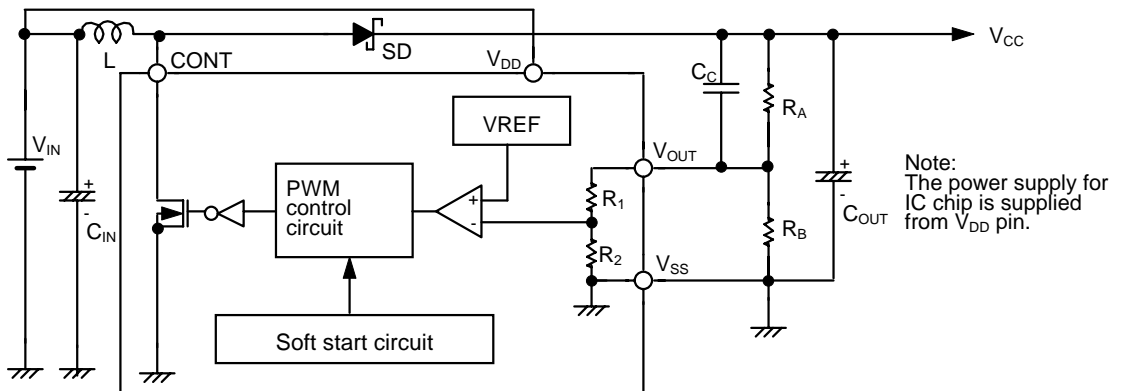
**SMALL PACKAGE PWM/PFM CONTROL STEP-UP SWITCHING REGULATOR**  
**S-8324/8328 Series**

(4) S-8328BXXMA  
S-8328BXXUA



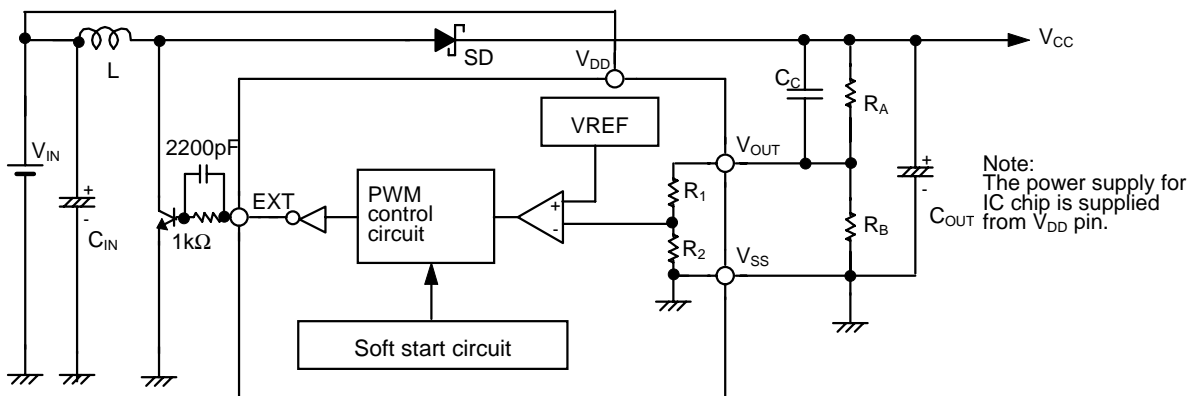
**Figure 13**

(5) S-8324DXXMC (Output voltage adjustment circuit with external resistors)



**Figure 14**

(6) S-8328EXXMC (Output voltage adjustment circuit with external resistors)



**Figure 15**

# SMALL PACKAGE PWM/PFM CONTROL STEP-UP SWITCHING REGULATOR

## S-8324/8328 Series

---

### ■ Precautions

- Mount external capacitors, a diode, and a coil as near as possible to the IC.
- Ripple voltage and spike noise occur in switching regulators. Because they largely depend on the coil and the capacitor used, check them using an actually mounted model.
- Seiko Instruments shall not be responsible for any patent infringement by products including S-8324/8328 Series in connection with the method of using S-8324/8328 Series in such products, the specification of such products, or the country of destination thereof.
- Make sure dissipation of the switching transistor (especially at a high temperatures) does not exceed the allowable power dissipation of the package.

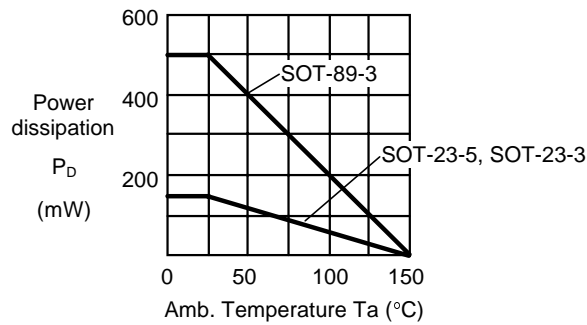


Figure 16 Power dissipation of the package (before mounting)

■ **Application Circuits**

**1. Backup Circuit**

Reduces the backup battery voltage from 3 V to 1.5 V (from 2 cells to 1 cell).

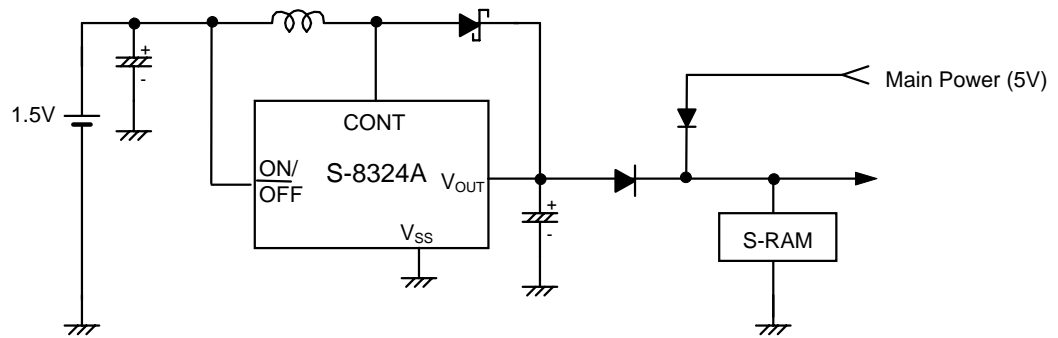


Figure 17

**2. 5V/Backup Change**

The S-8324A/8328B is provided with a power OFF function, where  $V_{OUT}$  becomes approx.  $V_{IN}-0.6V$ . This characteristic allows the backup voltage of the microcomputer to be supplied with low current consumption.

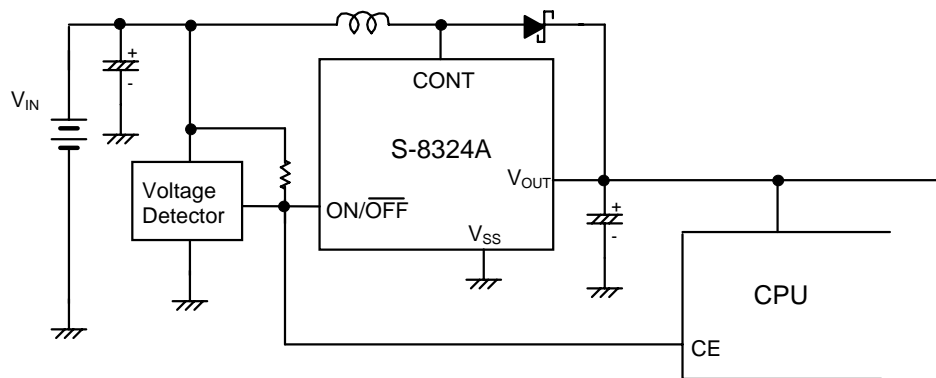


Figure 18

**3. Step-down DC/DC converter**

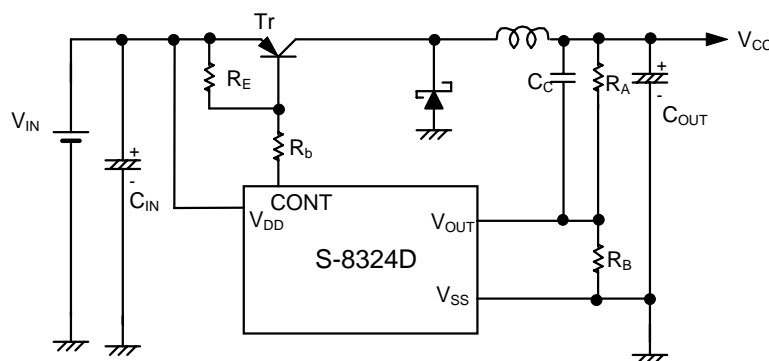


Figure 19

The start circuit is not needed because the power supply is supplied from  $V_{DD}$  to the IC.

The maximum input voltage for  $V_{DD}$  is 9 V.

DO NOT mount  $R_A$  and  $R_B$  resistors when  $V_{CC}$  is 2V for S-8324D20MC and 5V for S-8324D50MC.

The external resistor  $R_b$  must be 60Ω or more and  $R_E$  must be 6KΩ or less. A large value for  $R_E$  raises efficiency due to the reduction of reactive current for  $R_E$  and  $R_b$ .

Too large value of  $R_E$  lowers efficiency due to the large switching loss of the external transistor ( $Tr$ ). Choose a suitable value of  $R_E$  under the operating conditions.

# SMALL PACKAGE PWM/PFM CONTROL STEP-UP SWITCHING REGULATOR S-8324/8328 Series

## 4. PDA/Digital Camera Power Supply

The following are a circuit example and its characteristics showing a 3-V system drive (3V/200mA) powered by 4 secondary Nicd batteries (3.6 to 4.8V), 2 lithium-ion batteries (4.8 to 8.8V) or 4 alkaline-manganese batteries (3.6 to 6.0V).

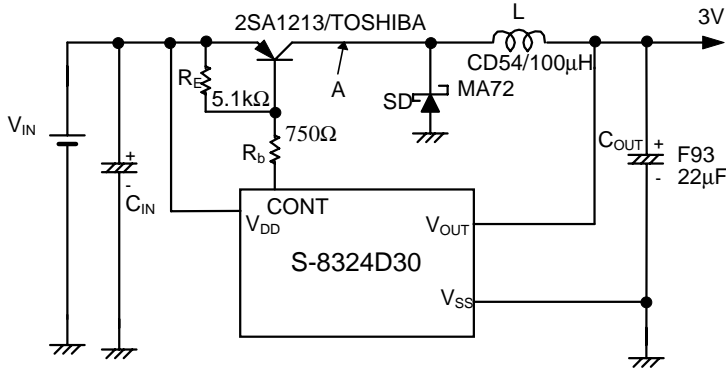


Figure 20

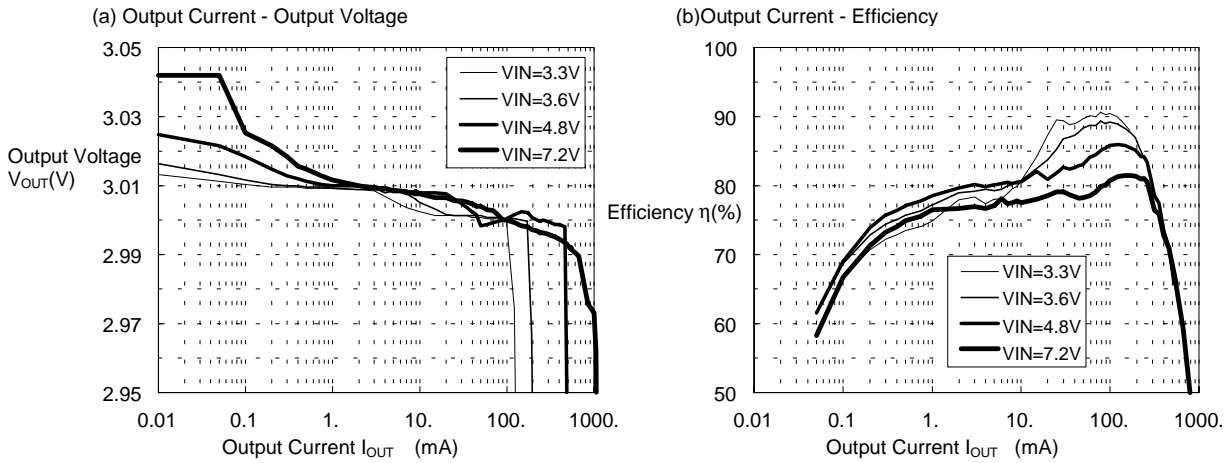


Figure 21

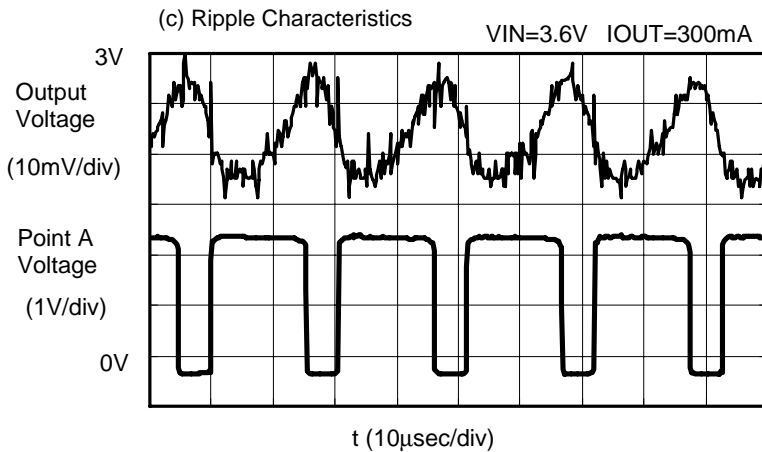
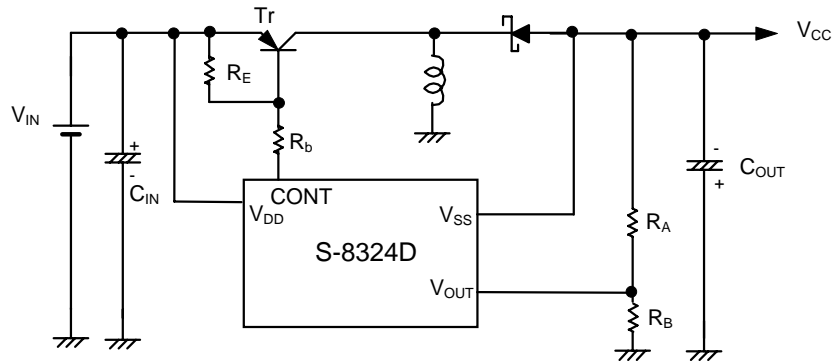


Figure 22

**5. Voltage Inverting Type DC/DC Converter**



**Figure 23**

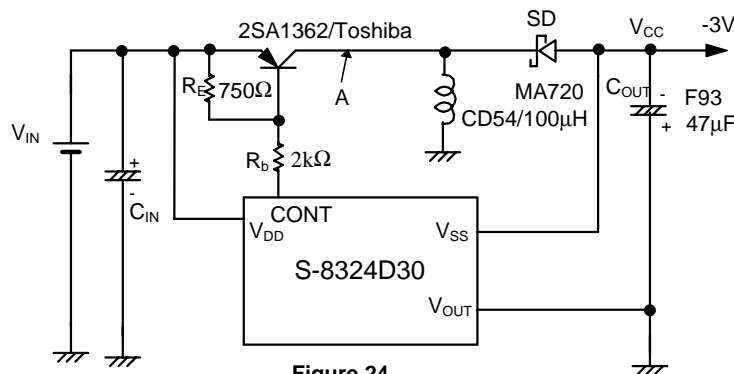
The Start circuit is not needed because the power is supplied from  $V_{DD}$  to the IC. Set  $V_{IN}$  to  $9V - |V_{CC}|$  or less.

When  $V_{CC}$  is -2 V, -3 V and -5 V, use the S-8324D20MC, the S-8324D30MC and the S-8324D50MC respectively. Always connect  $V_{OUT}$  to GND without attaching  $R_A$ ,  $R_B$ .

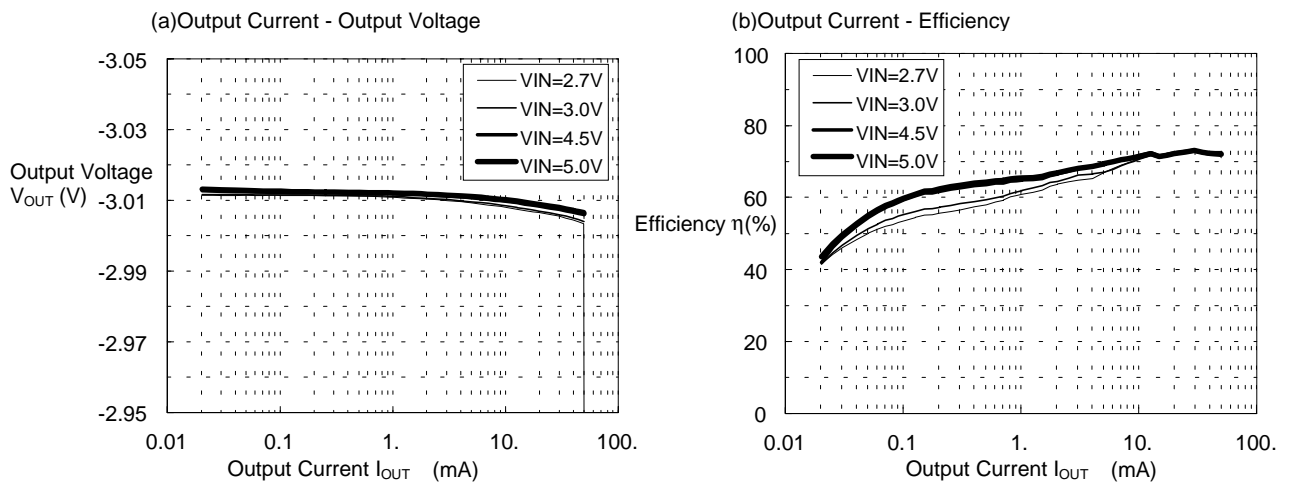
Set  $R_b$  to 60Ω or more and  $R_E$  to 6 kΩ or less. The larger  $R_b$ , the smaller the reactive current through  $R_E$  and  $R_b$ , allowing the efficiency to be improved. On the other hand, the switching loss of the Tr becomes large and consequently the efficiency will be worsend. Select  $R_E$  to ensure high efficiency under operating conditions.

**6. Power Supply for GaAs and MR Head**

The following are an application negative power supply circuit for GaAs and MR head, and its characteristics when 3V ( $3V \pm 10\%$ ) and 5V ( $5V \pm 10\%$ ) are used for the applied power. Set  $V_{IN}$  to  $9V - |V_{CC}|$  or less.

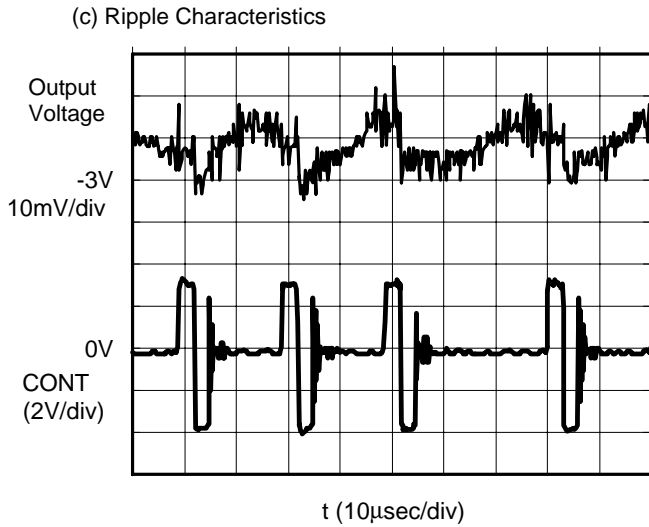


**Figure 24**



**Figure 25**

**SMALL PACKAGE PWM/PFM CONTROL STEP-UP SWITCHING REGULATOR**  
**S-8324/8328 Series**



**Figure 26**

When output current  $I_{OUT}$  exceeds 50 mA, the current capacitance in the external transistor 2SA1362 becomes in short supply and the IC may be broken. Select a large current capacitance transistor.

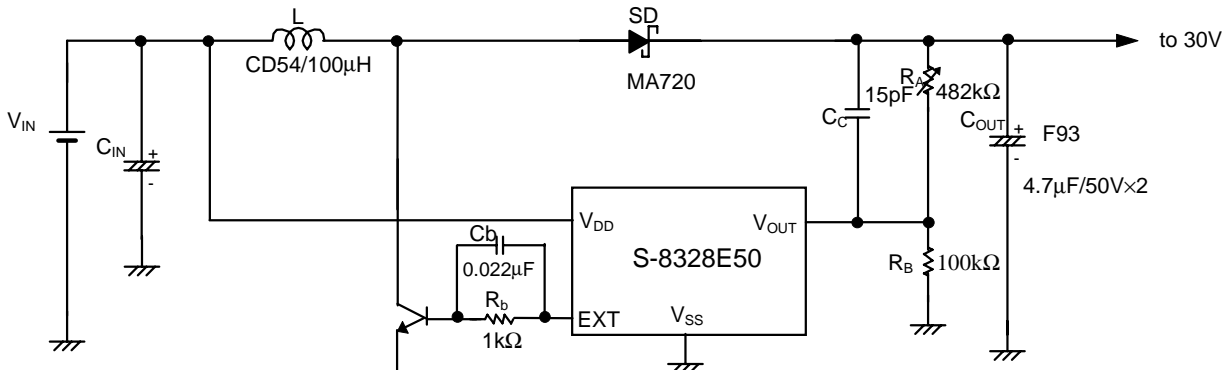
The start circuit is not needed because the power supply is supplied from  $V_{DD}$  to the IC. Set  $V_{in}$  to 9 V -  $|V_{CC}|$  or less.

The output voltage cannot be changed with external resistors.

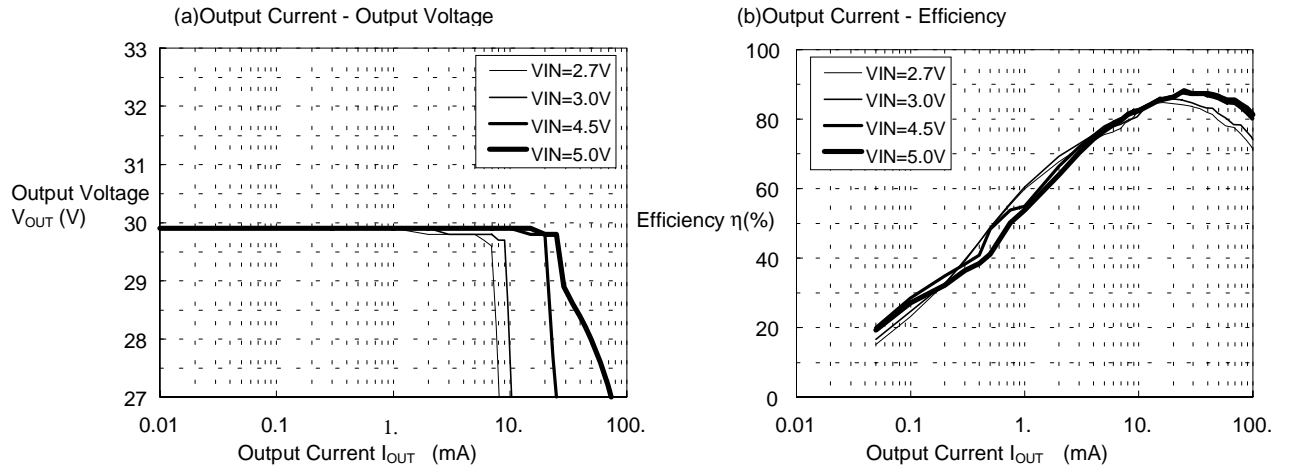
Set  $R_e$  to 60Ω or more and  $R_s$  to 6 kΩ or less. The larger  $R_e$ , the smaller the reactive current through  $R_e$  and  $R_s$ , allowing the efficiency to be improved. On the other hand, the switching loss of the Tr becomes large and consequently the efficiency will be worsened. Select  $R_e$  to ensure high efficiency under operating conditions.

**7. LCD Power Supply (Standard circuit (6))**

The following are an application power supply circuit (30V/5mA) for intermediate and large size LCD, and its characteristics when 3V ( $3V \pm 10\%$ ) and 5V ( $5V \pm 10\%$ ) are used for the applied power.



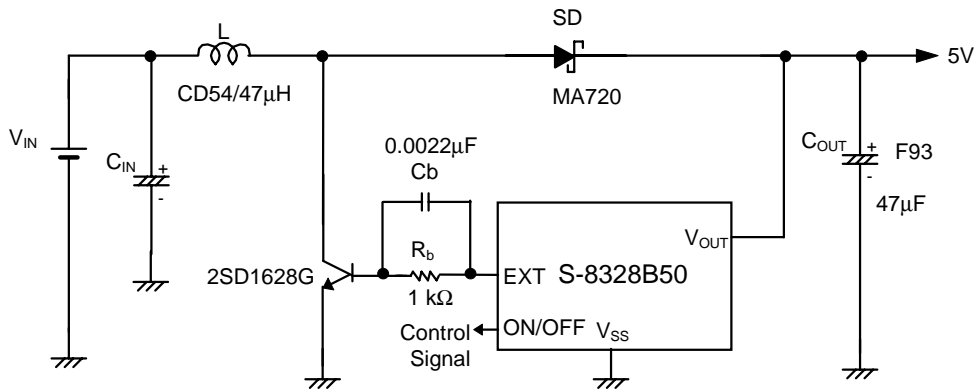
**Figure 27**



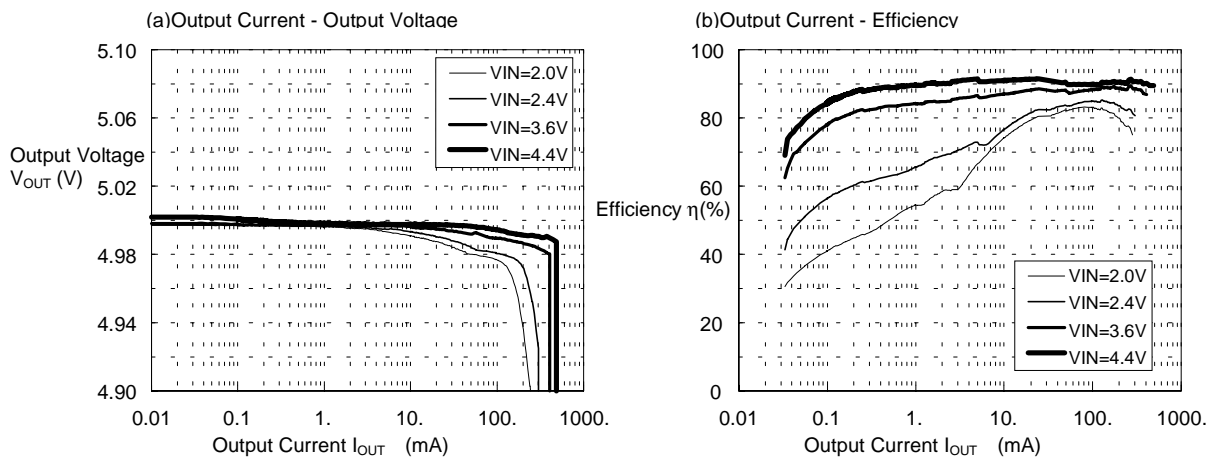
**Figure 28**

**8. Flash Memory Power Supply**

The following are a circuit example and its characteristics for a 5 V Flash Memory, 16 Mbit (5V/120mA) on a single lithium battery (2.4 V to 4.4 V).



**Figure 29**



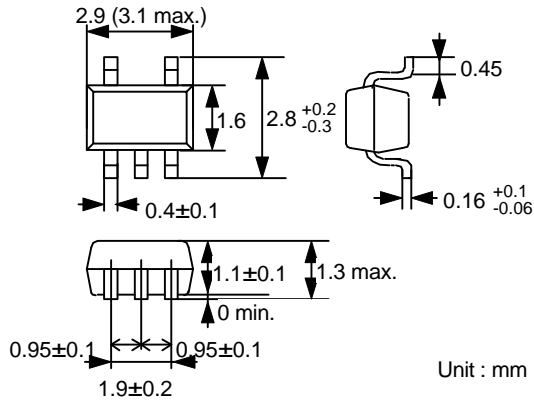
**Figure 30**



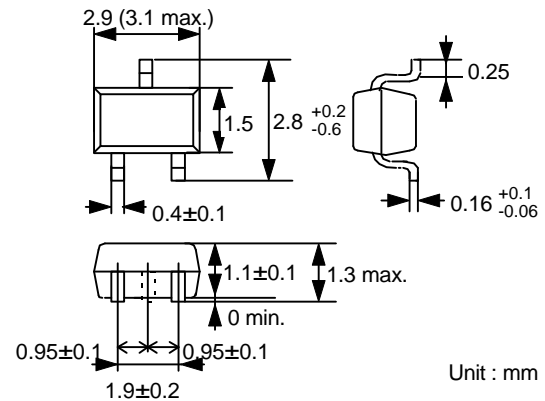
**SMALL PACKAGE PWM/PFM CONTROL STEP-UP SWITCHING REGULATOR**  
**S-8324/8328 Series**

■ **Dimensions**

(1) SOT-23-5



(2) SOT-23-3



(3) SOT-89-3

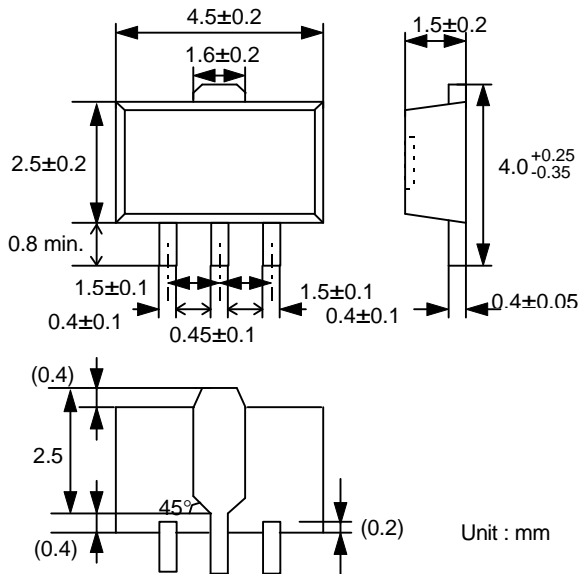
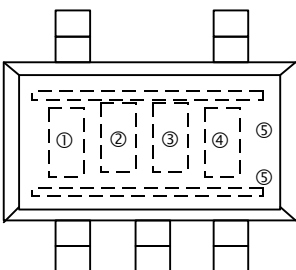


Figure 31

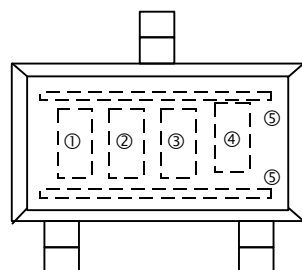
■ **Markings**

(1) SOT-23-5



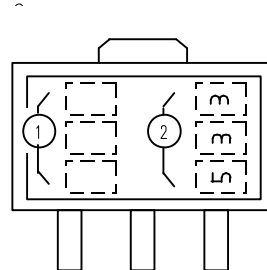
① to ② Product No. (abbreviation)  
 ④ to ⑤ Lot No.

(2) SOT-23-3



① to ③ Product No. (abbreviation)  
 ④ to ⑤ Lot No.

(3) SOT-89-3



① Product No. (abbreviation)  
 ② Lot No.

Figure 32

**SMALL PACKAGE PWM/PFM CONTROL STEP-UP SWITCHING REGULATOR**  
**S-8324/8328 Series**

■ Taping

1. Tape Specification

1-1 SOT-23-5

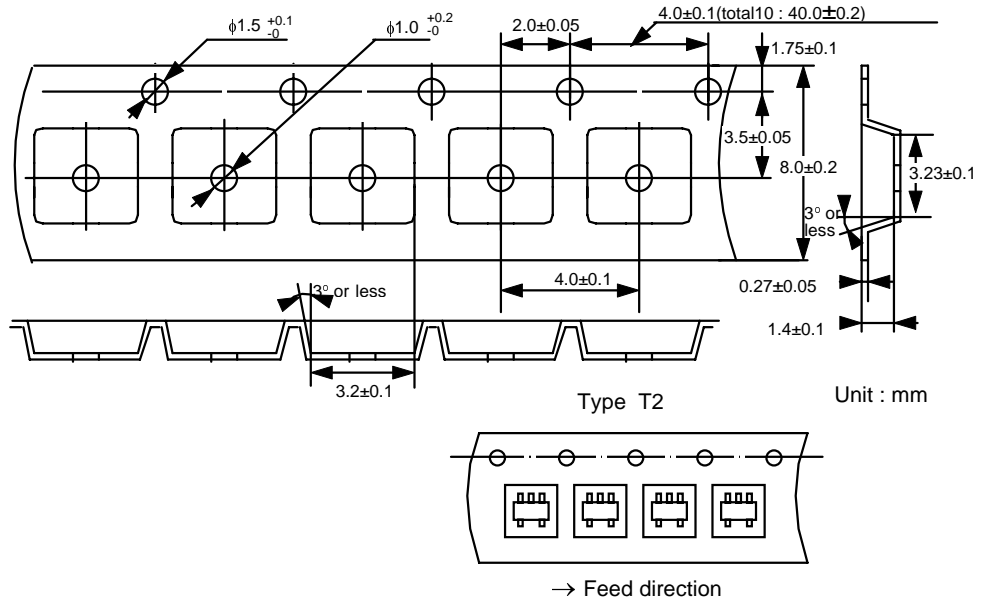


Figure 33

1-2 SOT-23-3

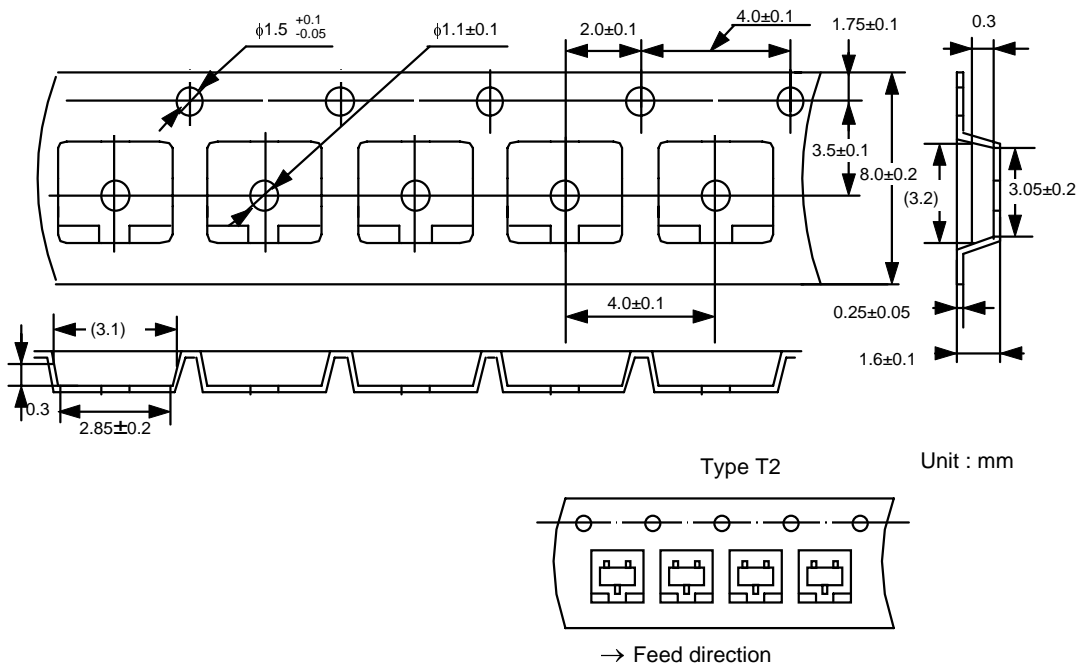


Figure 34

**SMALL PACKAGE PWM/PFM CONTROL STEP-UP SWITCHING REGULATOR**  
**S-8324/8328 Series**

1-3 SOT-89-3

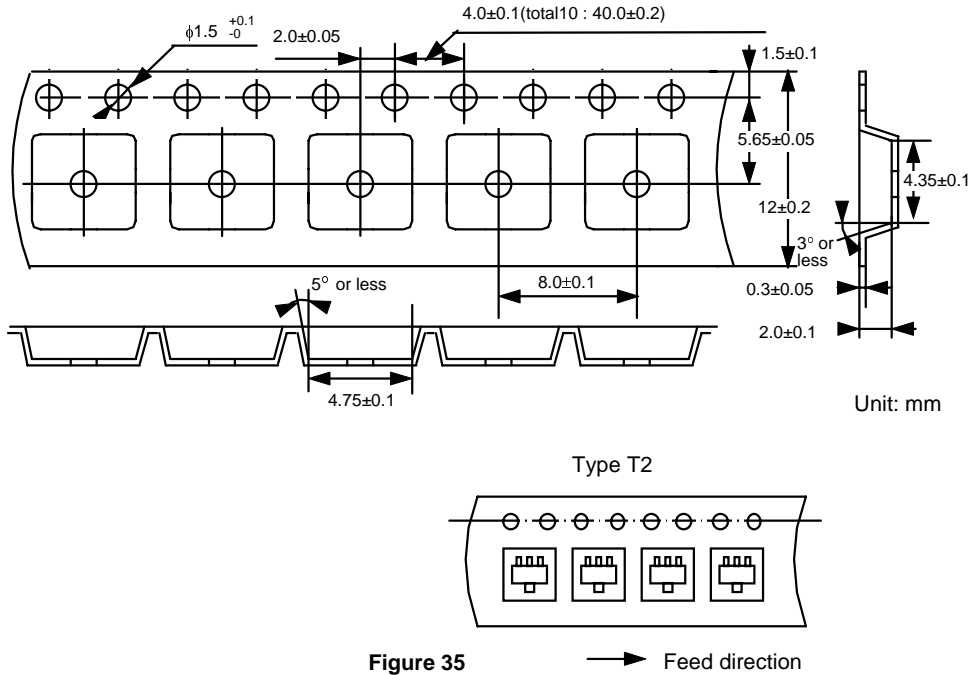


Figure 35

2. Reel Specifications

2-1 SOT-23-5/SOT-23-3

One reel holds 3000 regulators.

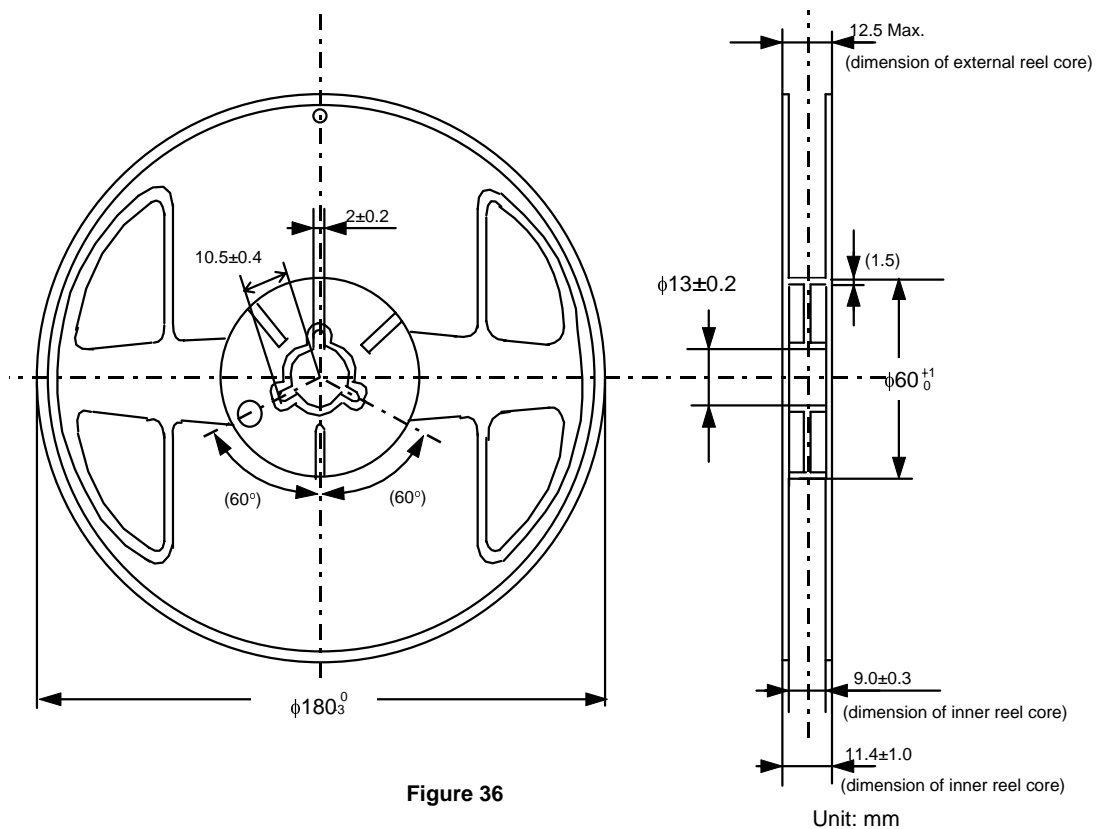


Figure 36

SMALL PACKAGE PWM/PFM CONTROL STEP-UP SWITCHING REGULATOR  
S-8324/8328 Series

2-2 SOT-89-3

One reel holds 1000 regulators.

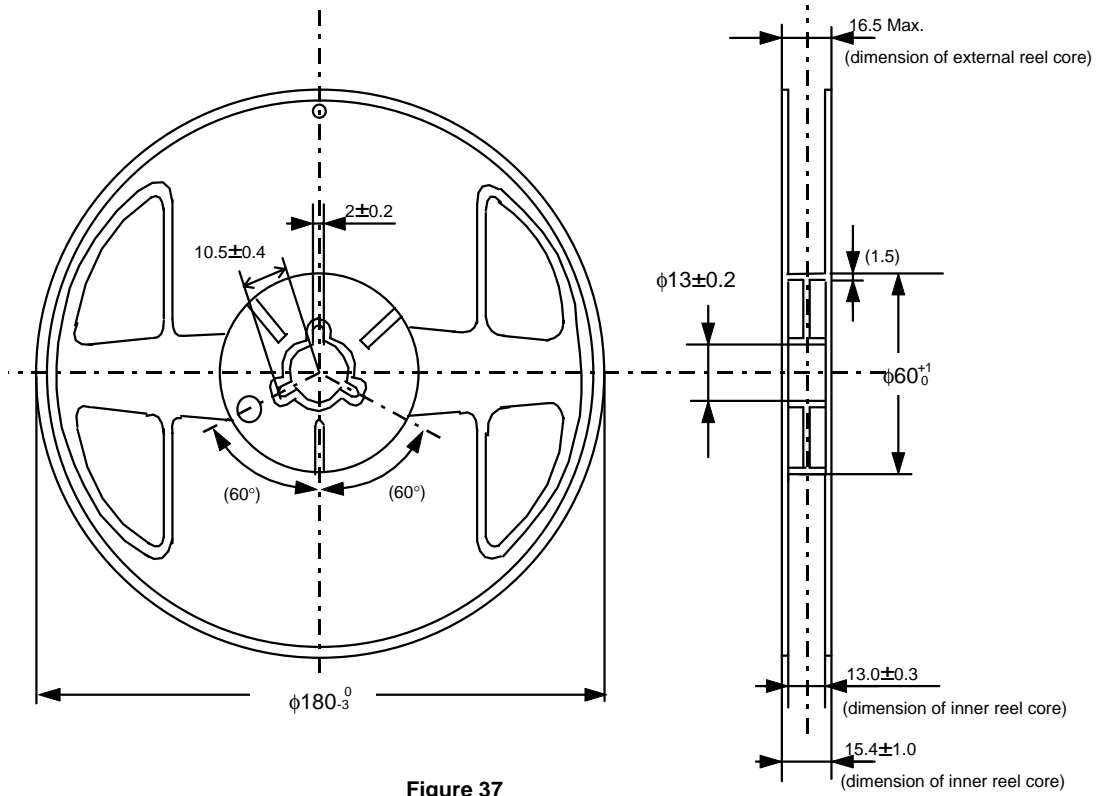


Figure 37

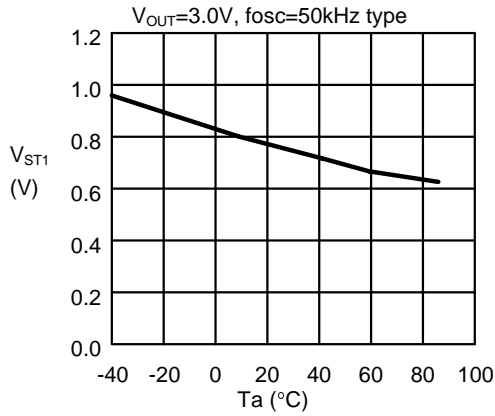
Unit: mm

# SMALL PACKAGE PWM/PFM CONTROL STEP-UP SWITCHING REGULATOR

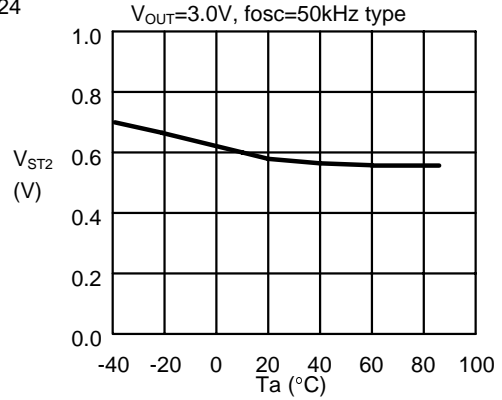
## S-8324/8328 Series

### Temperature Characteristics

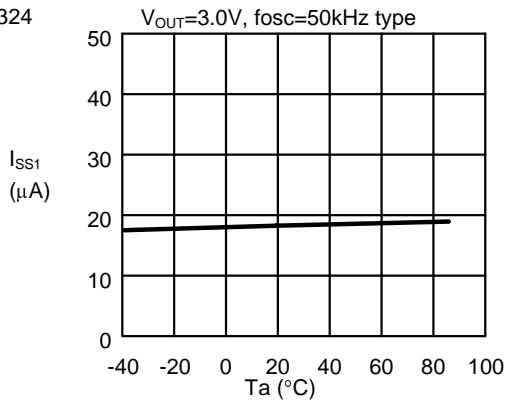
$V_{ST1}$  -  $T_a$   
S-8324



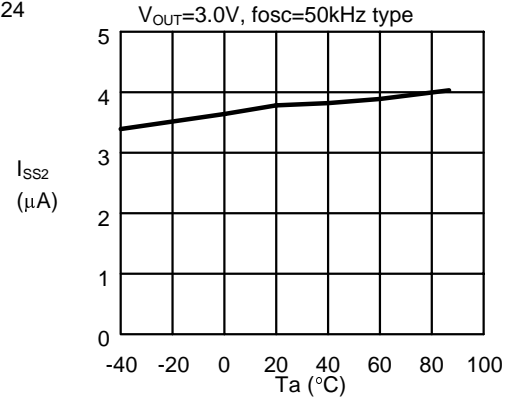
$V_{ST2}$  -  $T_a$   
S-8324



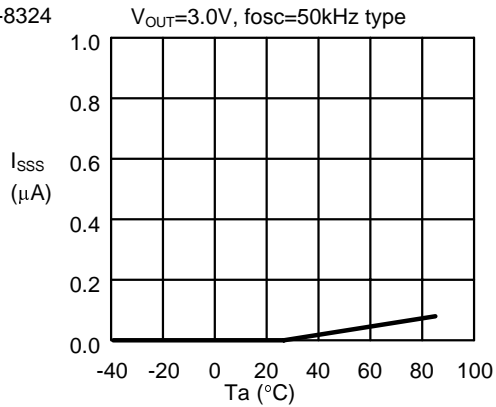
$I_{SS1}$  -  $T_a$   
S-8324



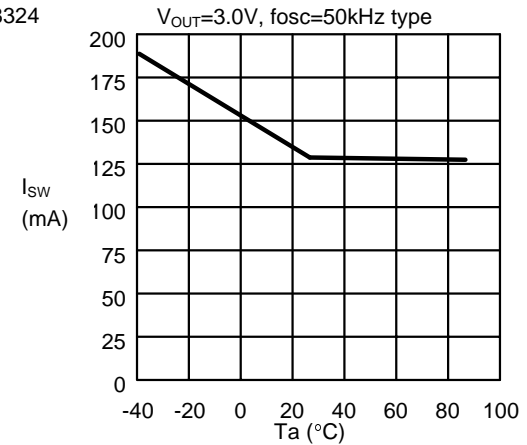
$I_{SS2}$  -  $T_a$   
S-8324



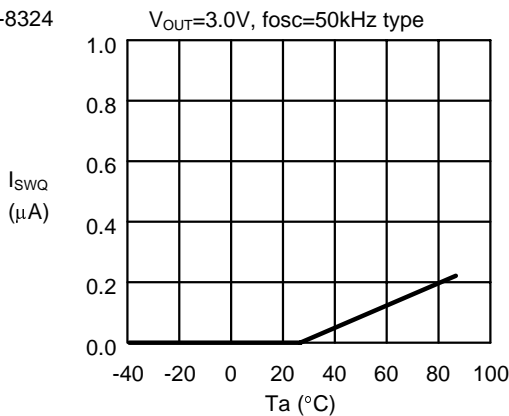
$I_{SS3}$  -  $T_a$   
S-8324



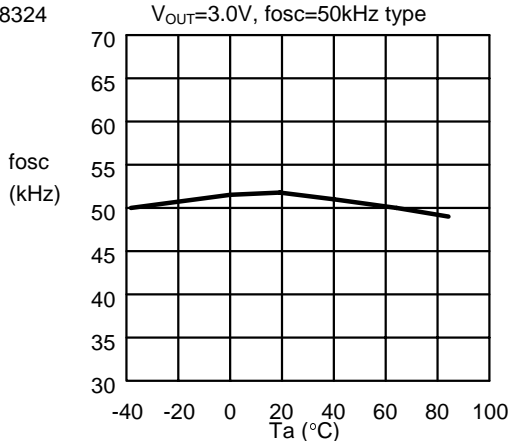
$I_{SW}$  -  $T_a$   
S-8324



$I_{SWQ}$  -  $T_a$   
S-8324

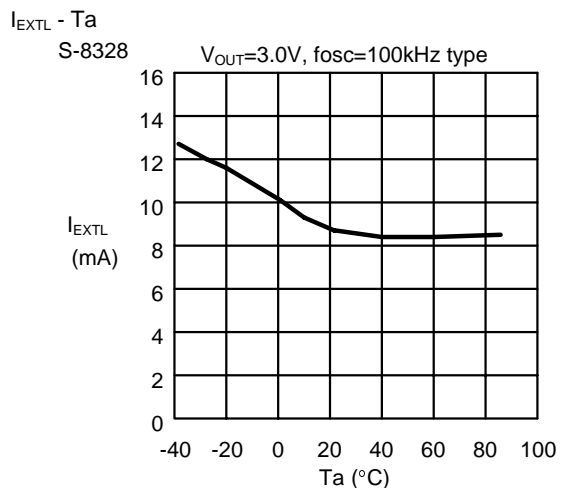
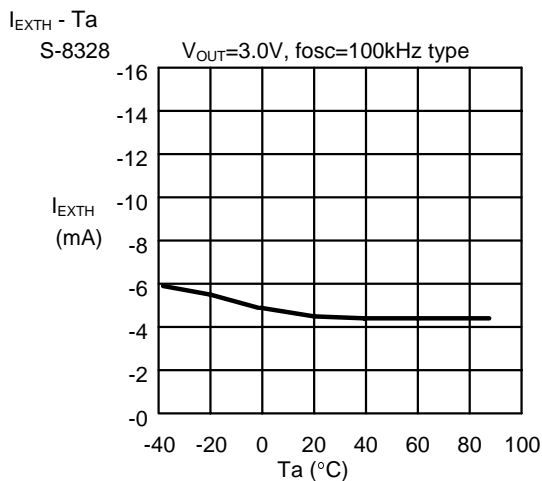
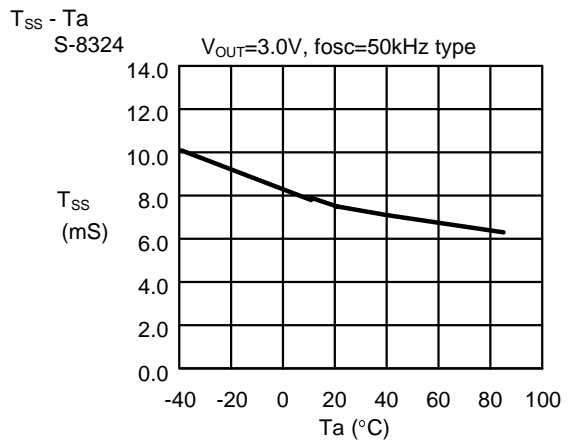
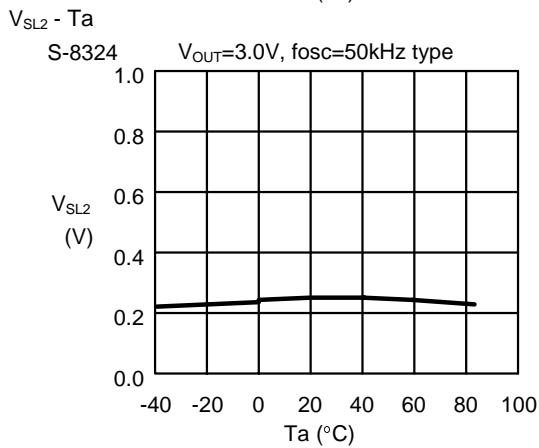
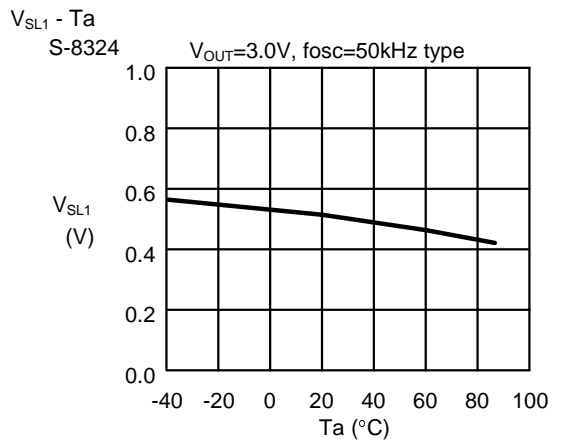
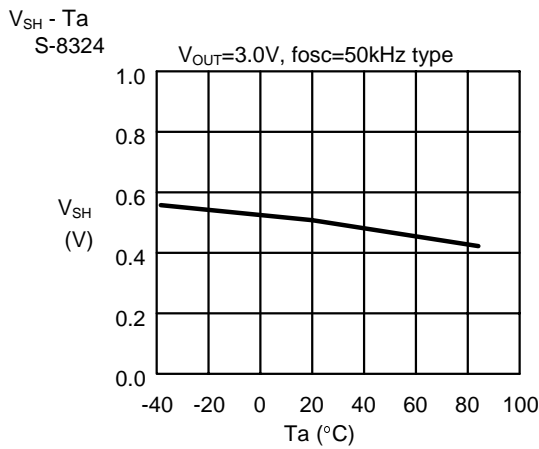
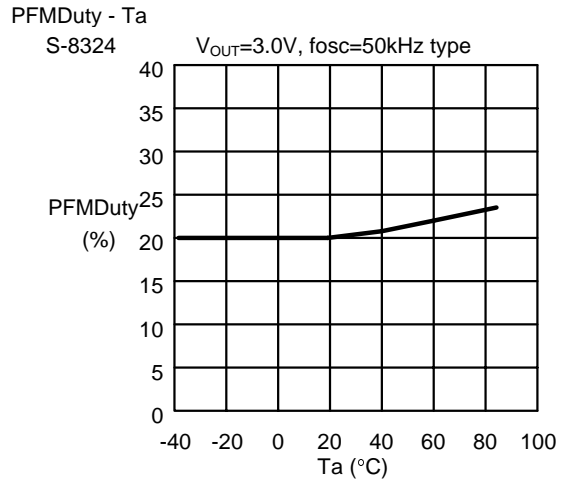
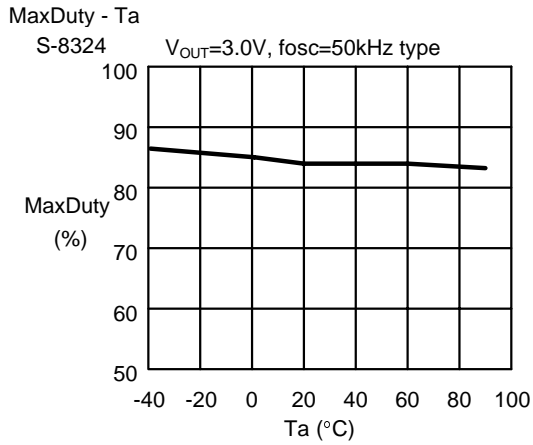


$f_{osc}$  -  $T_a$   
S-8324



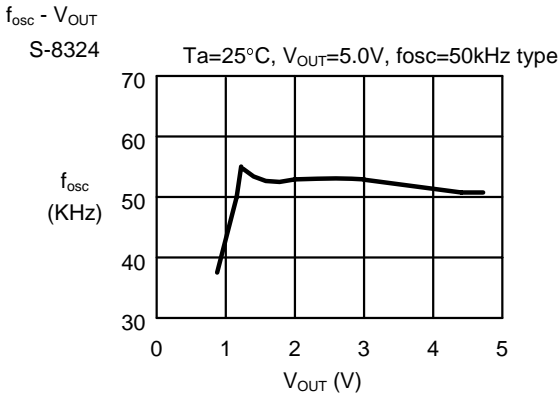
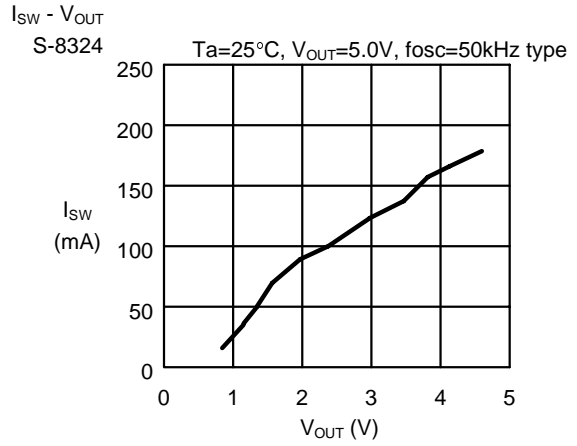
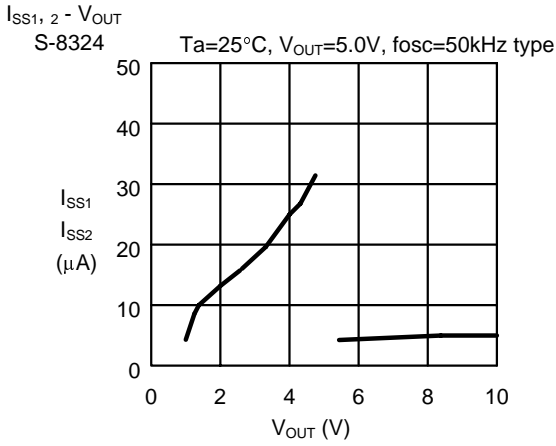
# SMALL PACKAGE PWM/PFM CONTROL STEP-UP SWITCHING REGULATOR

## S-8324/8328 Series



**SMALL PACKAGE PWM/PFM CONTROL STEP-UP SWITCHING REGULATOR**  
**S-8324/8328 Series**

■ **Characteristics for the Power Voltage**

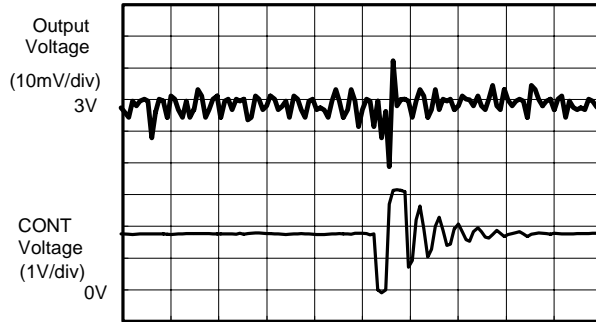


■ **Ripple characteristics**

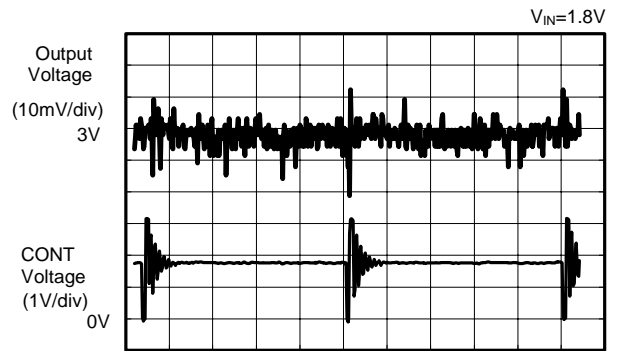
**S-8324A330**

1. Light Load ( $I_{OUT}=200\mu A$ )

$V_{IN}=1.8V$



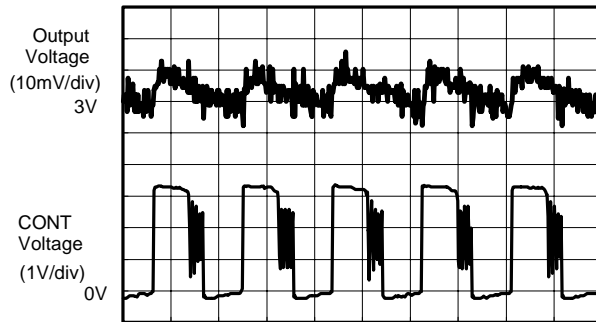
t (5µsec/div)



t (20µsec/div)

2. Medium Load ( $I_{OUT}=10mA$ )

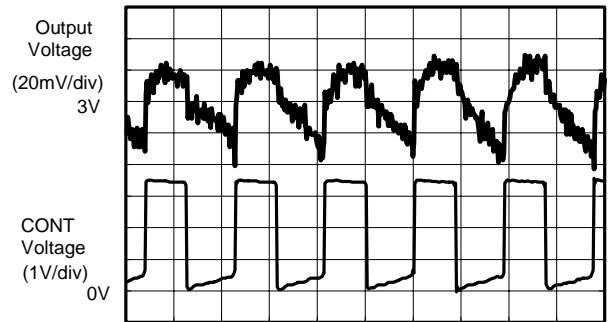
$V_{IN}=1.8V$



t (10µsec/div)

3. Heavy Load ( $I_{OUT}=60mA$ )

$V_{IN}=1.8V$

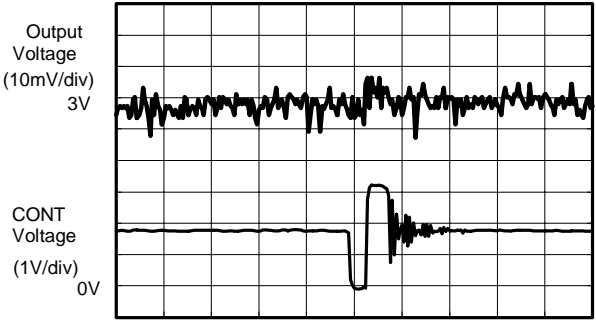


t (10µsec/div)

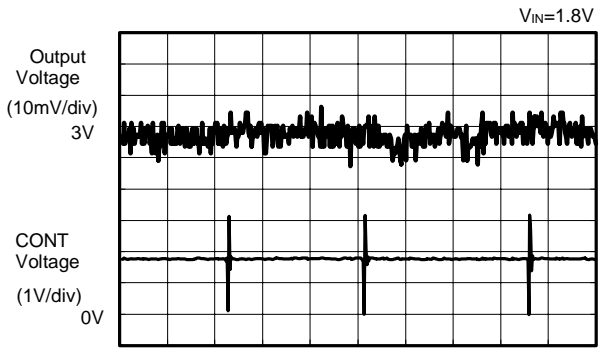
**S-8328B30**

1. Light Load ( $I_{OUT}=200\mu A$ )

$V_{IN}=1.8V$



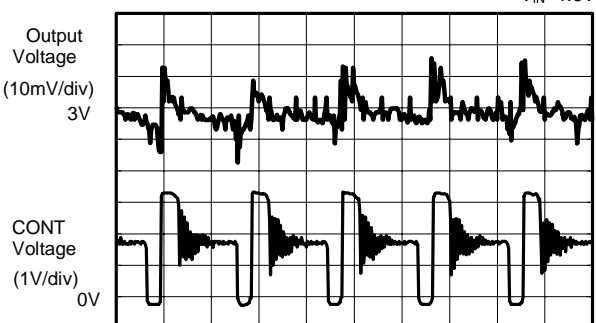
t (5µsec/div)



t (100µsec/div)

2. Medium Load ( $I_{OUT}=10mA$ )

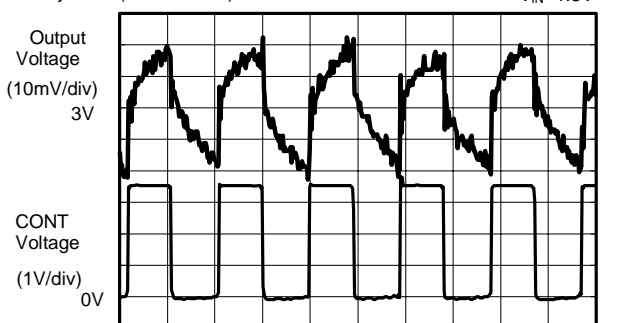
$V_{IN}=1.8V$



t (5µsec/div)

3. Heavy Load ( $I_{OUT}=200mA$ )

$V_{IN}=1.8V$



t (5µsec/div)



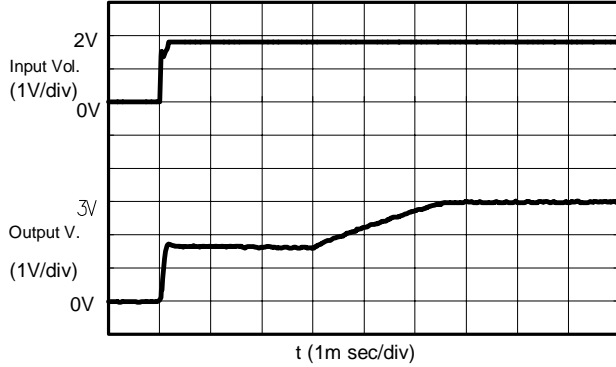
# SMALL PACKAGE PWM/PFM CONTROL STEP-UP SWITCHING REGULATOR

## S-8324/8328 Series

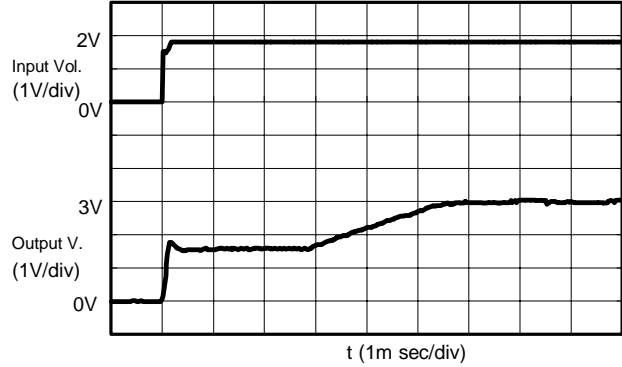
### ■ Transient Responses

1. Powering ON due to  $V_{IN}$  ( $V_{IN}:0V \rightarrow 1.8V$ )

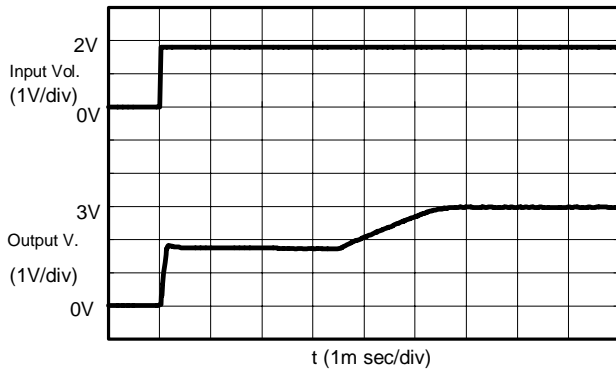
S-8324A30 (Light Load:  $I_{OUT}=1mA$ )



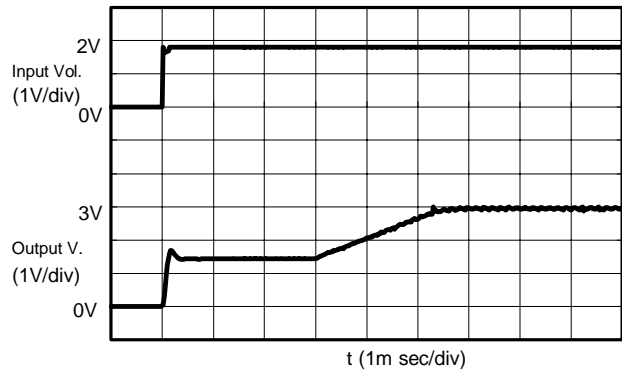
S-8324A30 (Heavy Load:  $I_{OUT}=60mA$ )



S-8328B30 (Light Load:  $I_{OUT}=1mA$ )



S-8328B30 (Heavy Load:  $I_{OUT}=200mA$ )



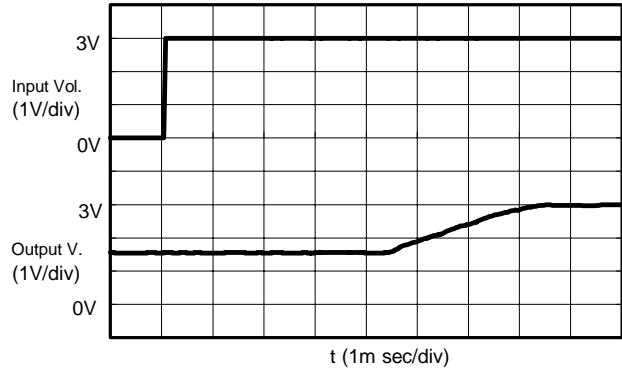
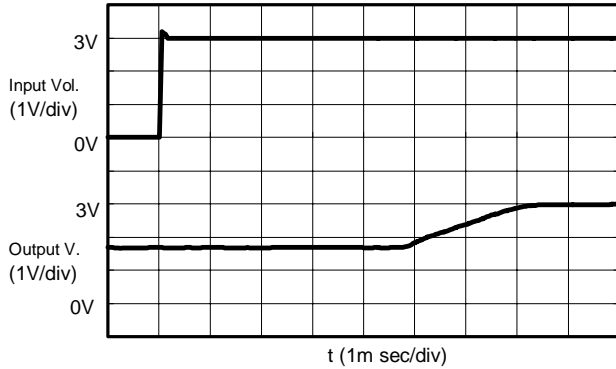
2. Powering ON due to Shutdown pin ( $V_{on/off}:0V \rightarrow 3.0V$ )

S-8324A30 (Light Load:  $I_{OUT}=1mA$ )

$V_{IN}=1.8V$

S-8324A30 (Heavy Load:  $I_{OUT}=60mA$ )

$V_{IN}=1.8V$

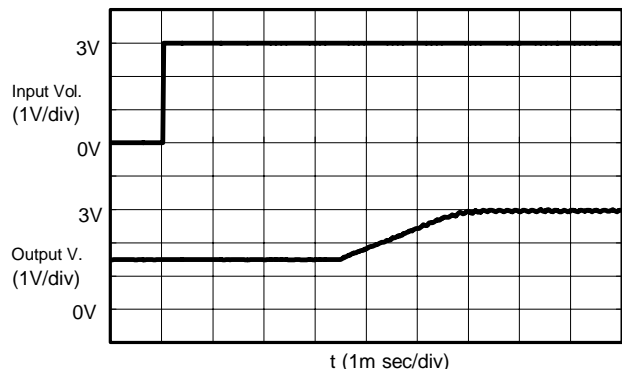
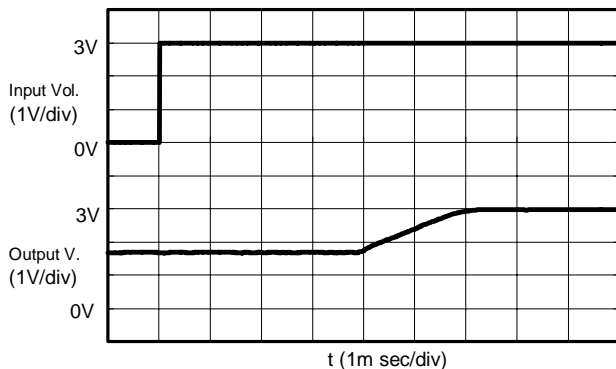


S-8328B30 (Light Load:  $I_{OUT}=1mA$ )

$V_{IN}=1.8V$

S-8328B30 (Heavy Load:  $I_{OUT}=200mA$ )

$V_{IN}=1.8V$

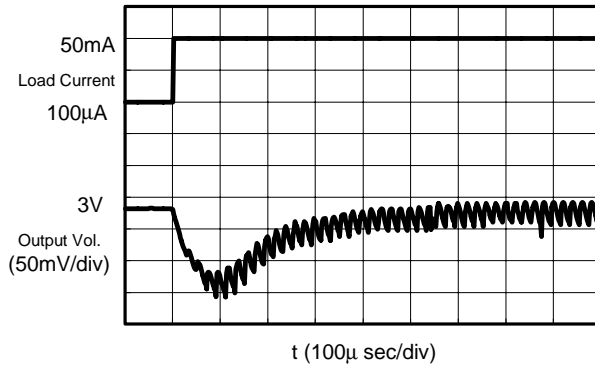


# SMALL PACKAGE PWM/PFM CONTROL STEP-UP SWITCHING REGULATOR S-8324/8328 Series

### 3. Load Fluctuations

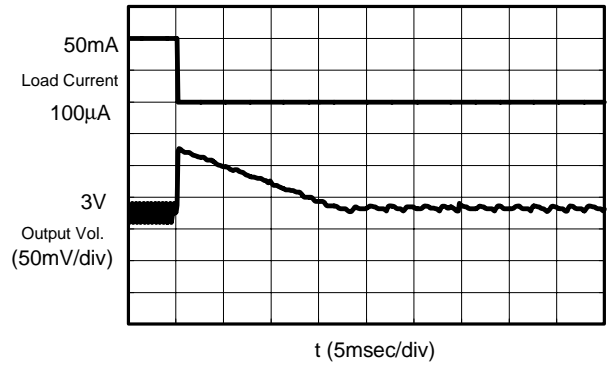
S-8324A30 ( $I_{OUT}: 100\mu A \rightarrow 50mA$ )

$V_{IN}=1.8V$



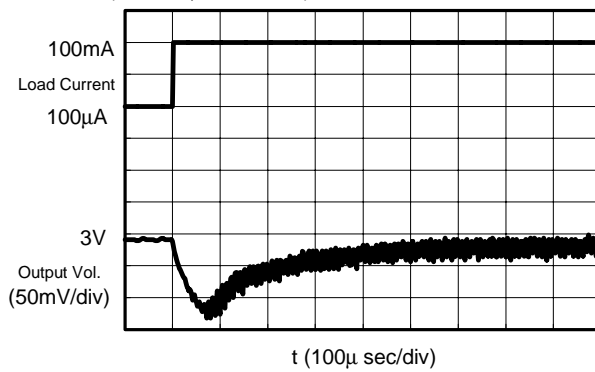
S-8324A30 ( $I_{OUT}: 50mA \rightarrow 100\mu A$ )

$V_{IN}=1.8V$



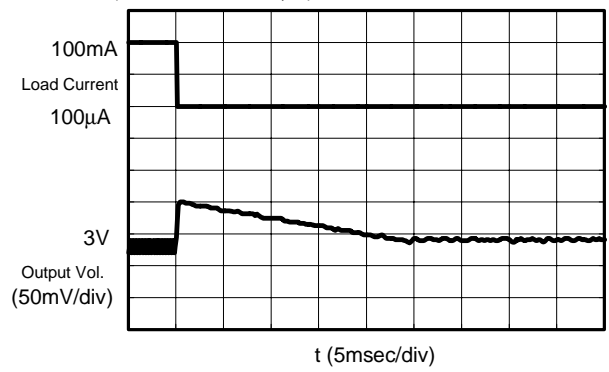
S-8328B30 ( $I_{OUT}: 100\mu A \rightarrow 100mA$ )

$V_{IN}=1.8V$



S-8328B30 ( $I_{OUT}: 100mA \rightarrow 100\mu A$ )

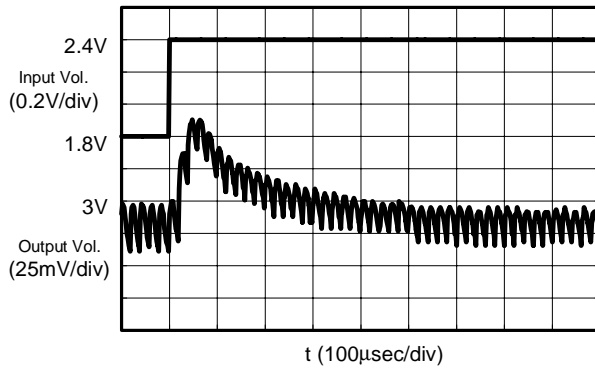
$V_{IN}=1.8V$



### 4. Power Voltage Fluctuations

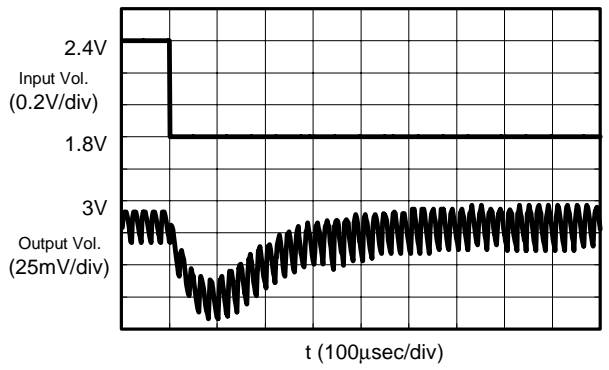
S-8324A30 ( $V_{IN}: 1.8V \rightarrow 2.4V$ )

$I_{OUT}=50mA$



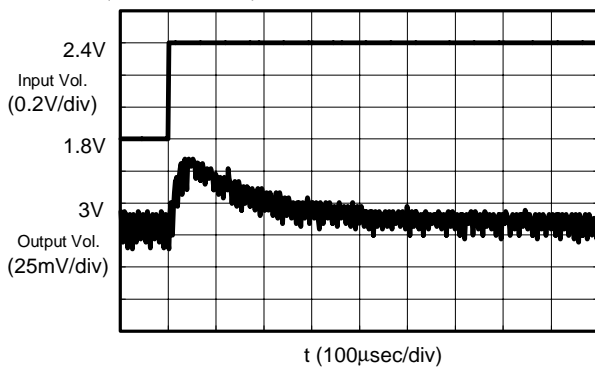
S-8324A30 ( $V_{IN}: 2.4V \rightarrow 1.8V$ )

$I_{OUT}=50mA$



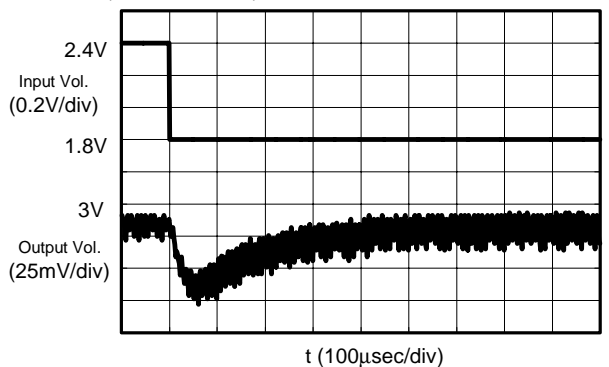
S-8328B30 ( $V_{IN}: 1.8V \rightarrow 2.4V$ )

$I_{OUT}=100mA$



S-8328B30 ( $V_{IN}: 2.4V \rightarrow 1.8V$ )

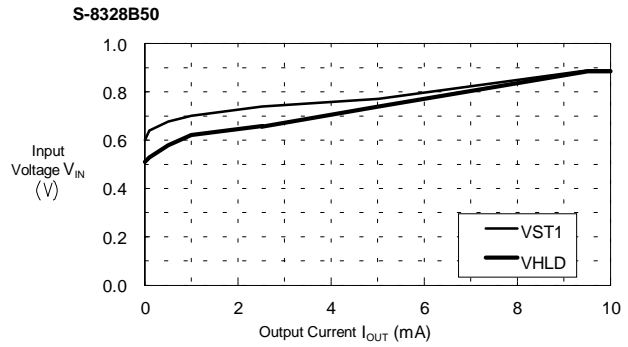
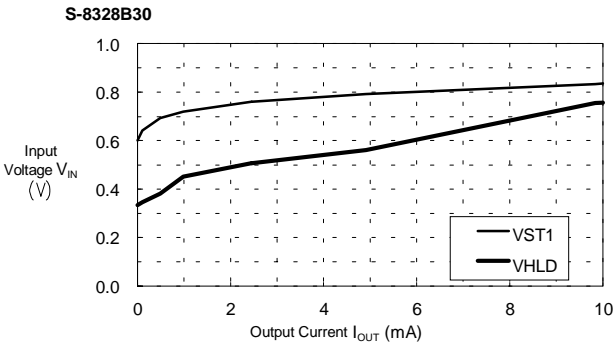
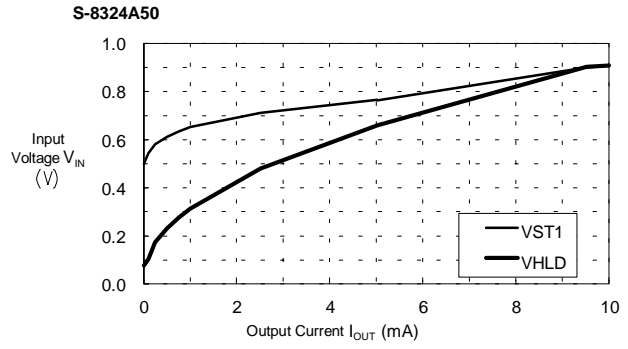
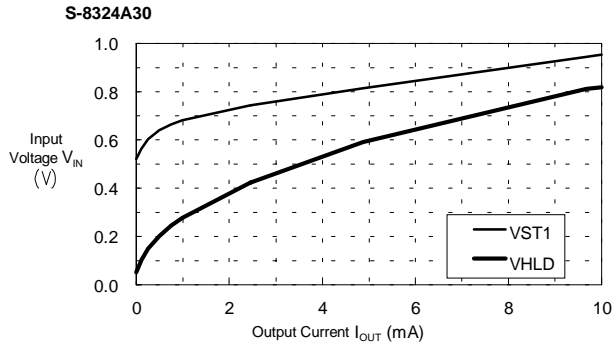
$I_{OUT}=100mA$



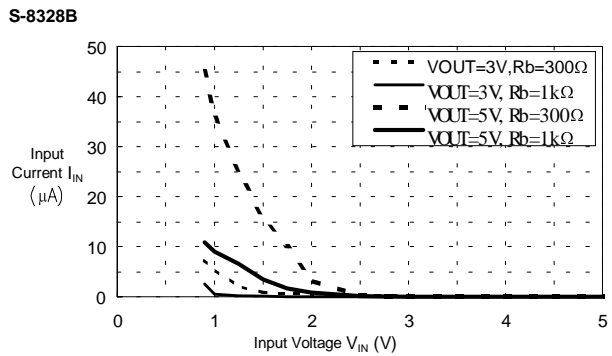
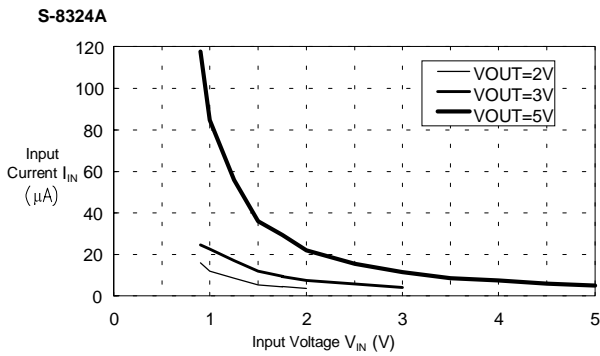
# SMALL PACKAGE PWM/PFM CONTROL STEP-UP SWITCHING REGULATOR

## S-8324/8328 Series

### ■ Operation Start Voltage and Operation Holding Voltage Characteristics for Output Current



### ■ Input Voltage Characteristics for Input Current

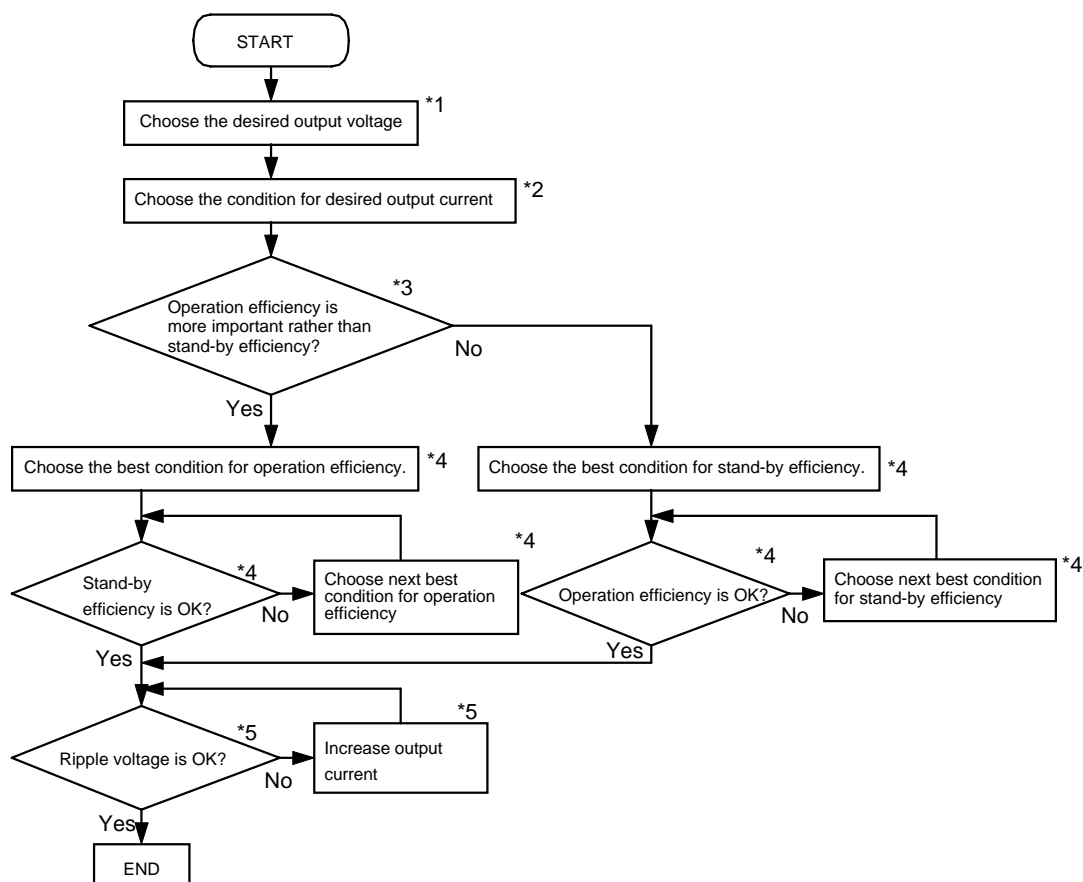


■ **Reference Data**

Use reference data to choose the external parts.

Reference data give you the procedure to choose the recommended external parts for various applications and its characteristics data.

1. Procedure to choose the most suitable condition from reference data.



- \*1) Choose desired output voltage from conditions (1) to (17) shown in Table 1 and 2.  
When desired output voltage does not exist in Tables, choose the next higher voltage.  
For instance, when  $V_{OUT}=3V$  for S-8324, choose from conditions (3) to (6).
- \*2) Choose all conditions from conditions chosen above for output current needed for input voltage (min) of the operational condition from "Reference data 1 (a) output voltage characteristics for output current".  
For instance, when 10mA output current is needed at  $V_{IN}=0.9V$ , choose from conditions (4) to (6).
- \*3) Stand-by efficiency means the efficiency when the output current is small (approx. 100 $\mu$ A), operation efficiency means the efficiency when the output current is large (several mA).  
For instance, go to "YES" when operation efficiency is more important rather than stand-by efficiency.
- \*4) Read the efficiency for input voltage and output current in operational condition from "Reference data 1 (b) efficiency characteristics for output current".  
For instance, when  $V_{IN}=0.9V$  at  $I_{OUT}=10mA$ , the efficiency is max. (75%) in condition (6) in conditions (4) to (6).  
There is no difference between conditions (4) to (6) when the output current is 100 $\mu$ A at stand-by condition.  
Therefore, choose condition (6).
- \*5) Read the ripple voltage under the operational condition selected above from "Reference data 2 ripple voltage characteristics for output current".  
For instance, when condition (6) is selected above, the ripple voltage is mV at  $V_{IN}=0.9V$  and  $I_{OUT}=10mA$ .

# SMALL PACKAGE PWM/PFM CONTROL STEP-UP SWITCHING REGULATOR

## S-8324/8328 Series

**Table 1 S-8324 Series**

No.	V <sub>OUT</sub>	Model name of L	L value	D	C <sub>OUT</sub>
(1)	2V	LQH3C	220μH	MA720	22μF
(2)	2V	LQH4N	220μH	↑	↑
(3)	3V	LQH4N	220μH	↑	↑
(4)	3V	CD54	47μH	↑	↑
(5)	3V	CD54	100μH	↑	↑
(6)	3V	CD54	220μH	↑	↑
(7)	5V	CD54	47μH	↑	↑
(8)	5V	CD54	100μH	↑	↑
(9)	5V	CD54	220μH	↑	↑

**Table 2 S-8328 Series**

No.	V <sub>OUT</sub>	Model name of L	L value	Rb	Cb	D	C <sub>OUT</sub>
(10)	3V	CD105	22μH	300Ω	0.01μF	MA735	47μF×2
(11)	3V	CD105	22μH	1KΩ	0.0022μF	MA735	47μF×2
(12)	3V	CD54	47μH	1KΩ	0.0022μF	MA720	47μF
(13)	3V	D75C	47μH	1KΩ	0.0022μF	MA720	47μF
(14)	5V	CD105	22μH	300Ω	0.01μF	MA735	47μF×2
(15)	5V	CD105	22μH	1KΩ	0.0022μF	MA735	47μF×2
(16)	5V	CD54	47μH	1KΩ	0.0022μF	MA720	47μF
(17)	5V	D75C	47μH	1KΩ	0.0022μF	MA720	47μF

The efficiency of the external parts are shown below

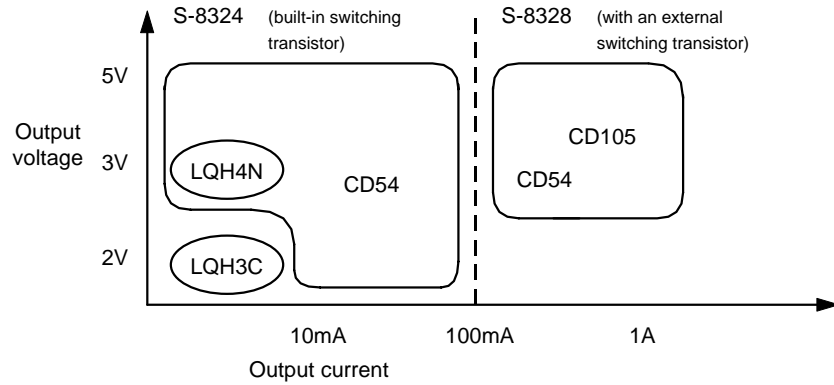
**Table 3**

Part	Model name	Vendor	L value	DC resistance	Max allowable current	Diameter	Height
Inductor	CD105	Sumida	22μH	0.10Ω	1.95A	10.0mm	5.4mm
	CD54	↑	47μH	0.37Ω	0.72A	5.8mm	4.5mm
	↑	↑	100μH	0.70Ω	0.52A	↑	↑
	↑	↑	220μH	1.57Ω	0.35A	↑	↑
	LQH4N	Murata	220μH	5.40Ω	0.11A	4.5mm	2.6mm
	LQH3C	↑	220μH	8.40Ω	0.07A	3.2mm	2.0mm
	D75C	Toko	47μH	0.20Ω	0.76A	7.6mm	5.1mm
	↑	↑	100μH	0.40Ω	0.50A	↑	↑
Diode (Schott key)	MA720	Matsushita	forward current 500mA (at V <sub>F</sub> =0.55V)				
	MA735	↑	forward current 1A (at V <sub>F</sub> =0.5V)				
Output capacitor	F93	Nichicon					
External transistor	2SD1628G	Sanyo					

# SMALL PACKAGE PWM/PFM CONTROL STEP-UP SWITCHING REGULATOR

## S-8324/8328 Series

Choose the suitable inductor from Table 3 according to the Figure 34.



**Figure 38 Inductors for output current**

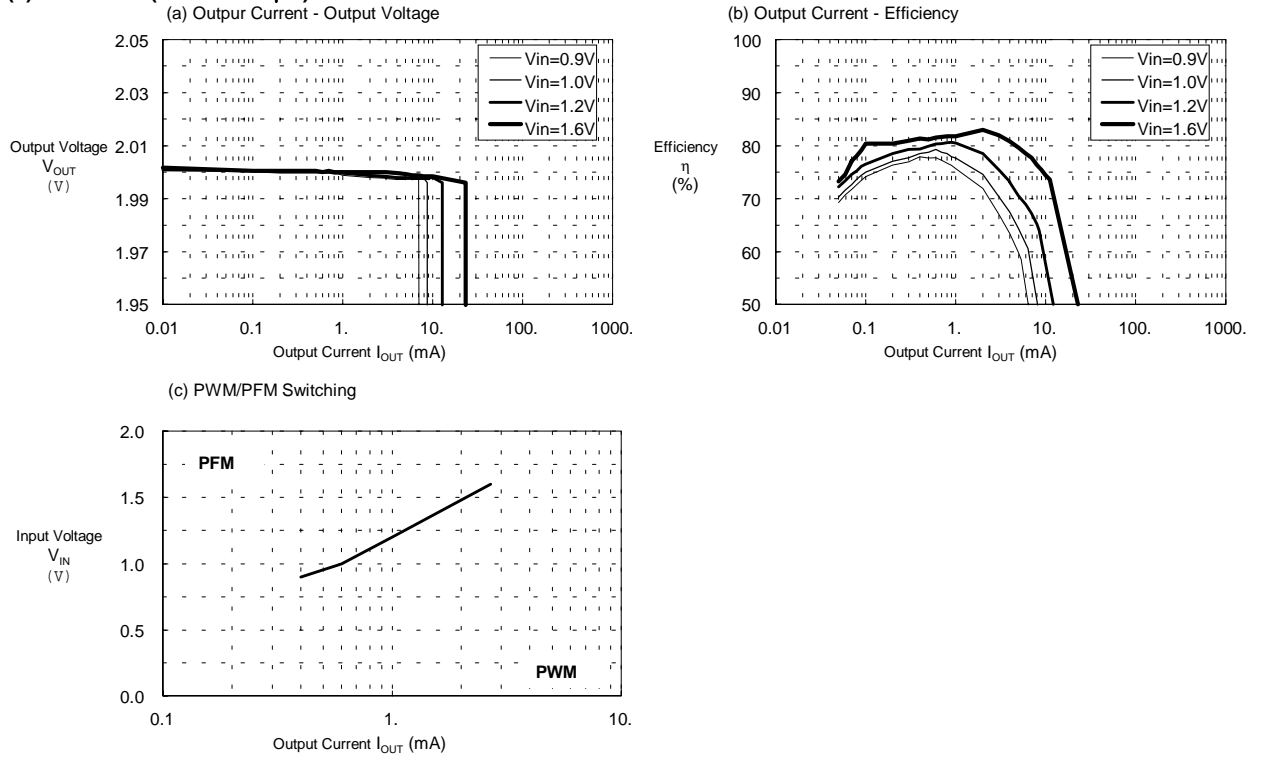
The S-8324/28 Series improves efficiency by switching PWM control to PFM control automatically when the output current is decreased.

The reference data 1 shows the output current data switching PWM control to PFM control.

Reference Data 1

(a) output voltage characteristics for output current, (b) efficiency characteristics for output current and (c) PWM/PFM switching characteristics under (1) to (17) conditions shown in Table 1 and 2 are shown below.

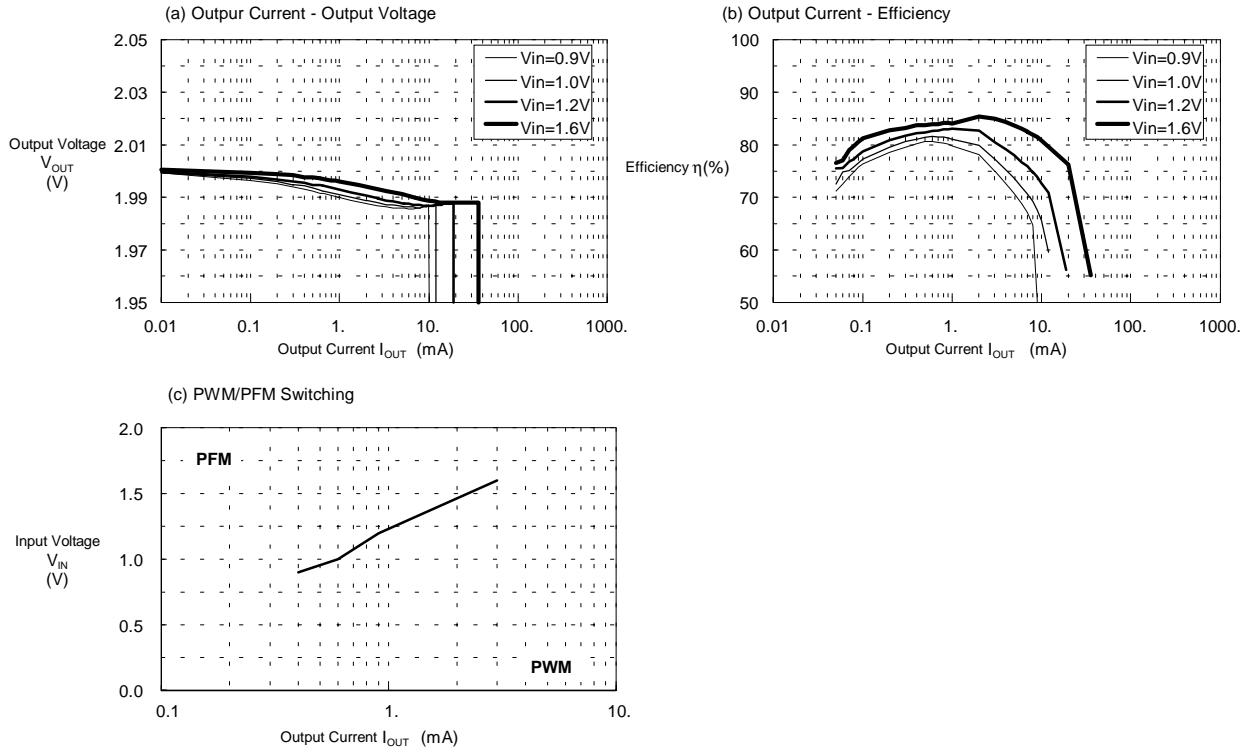
**(1) S-8324A20(LQH3C:220μH)**



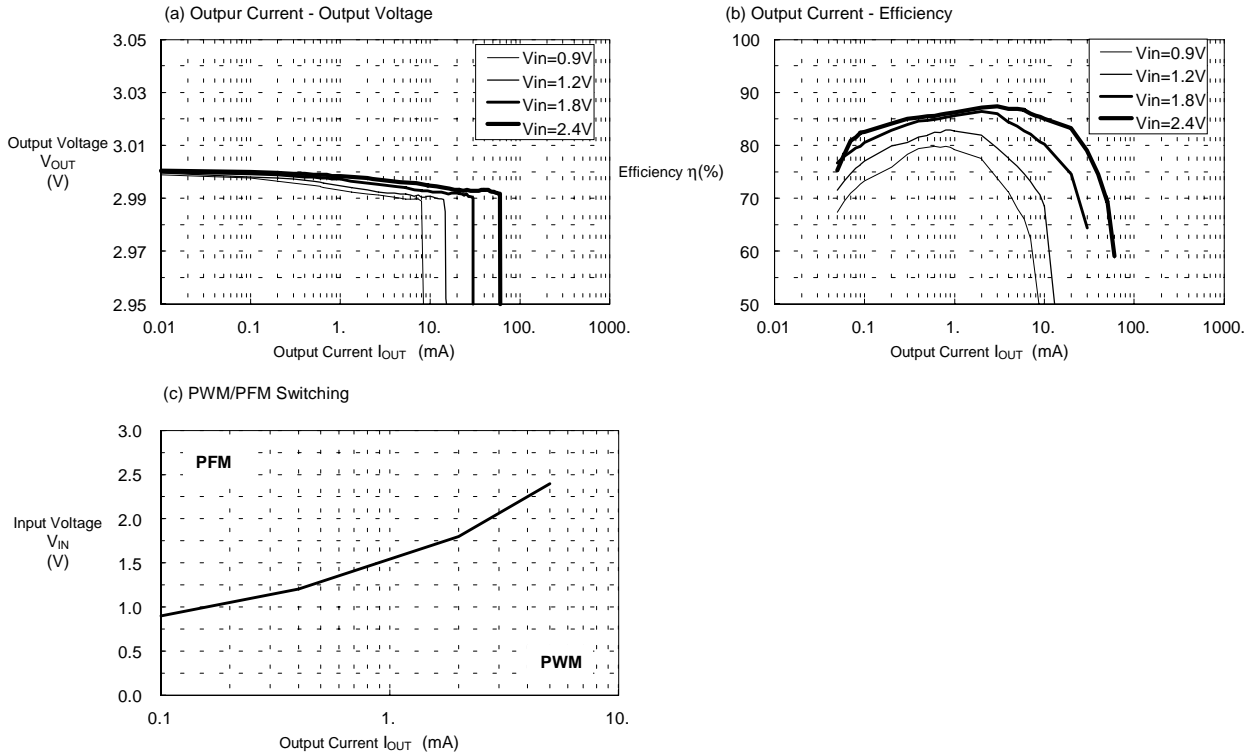
# SMALL PACKAGE PWM/PFM CONTROL STEP-UP SWITCHING REGULATOR

## S-8324/8328 Series

### (2) S-8324A20 (LQH4N : 220 $\mu$ H)



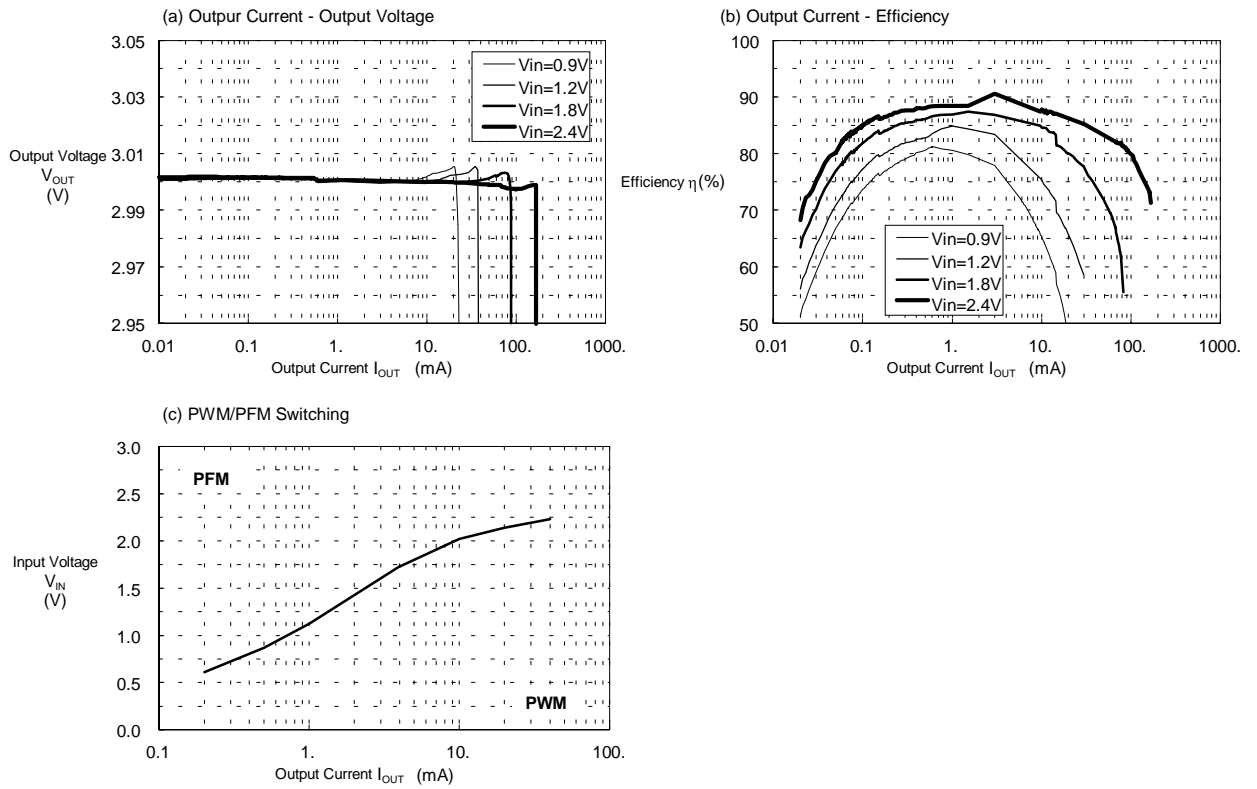
### (3) S-8324A30 (LQH4N : 220 $\mu$ H)



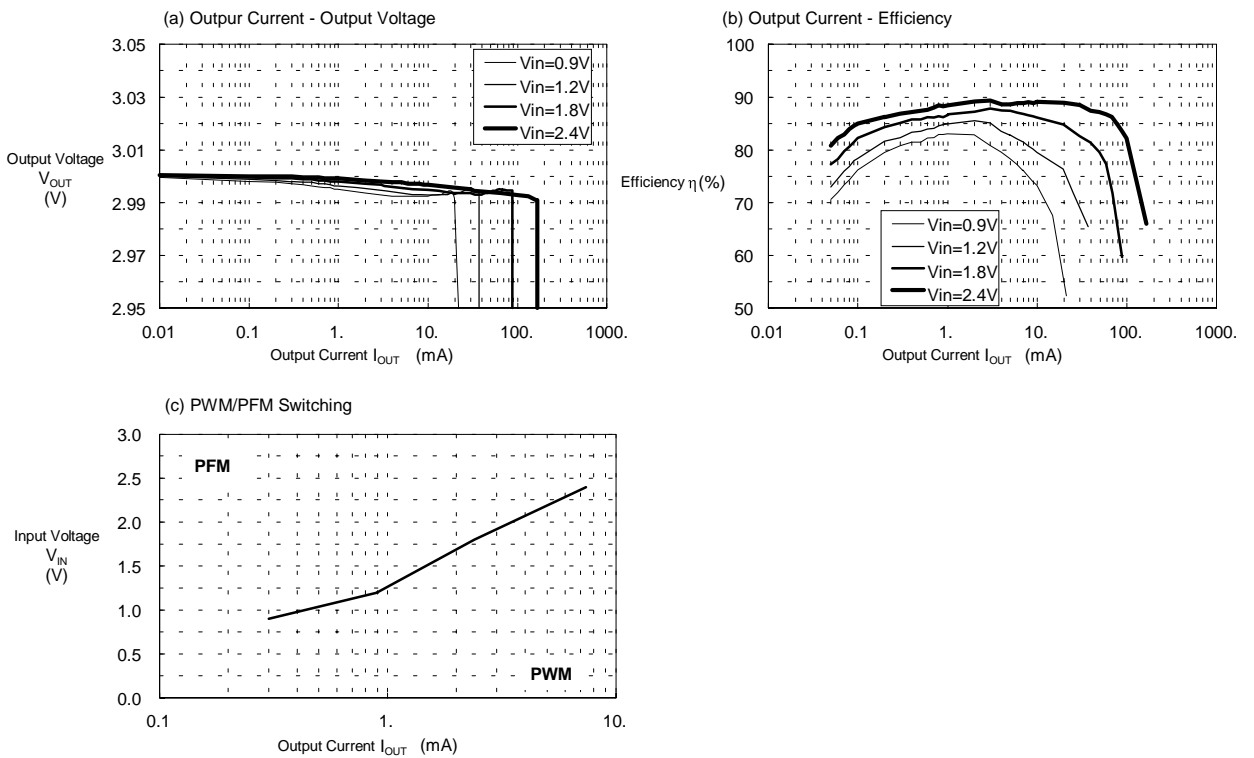
# SMALL PACKAGE PWM/PFM CONTROL STEP-UP SWITCHING REGULATOR

## S-8324/8328 Series

### (4) S-8324A30 (CD54 : 47 $\mu$ H)



### (5) S-8324A30 (CD54 : 100 $\mu$ H)

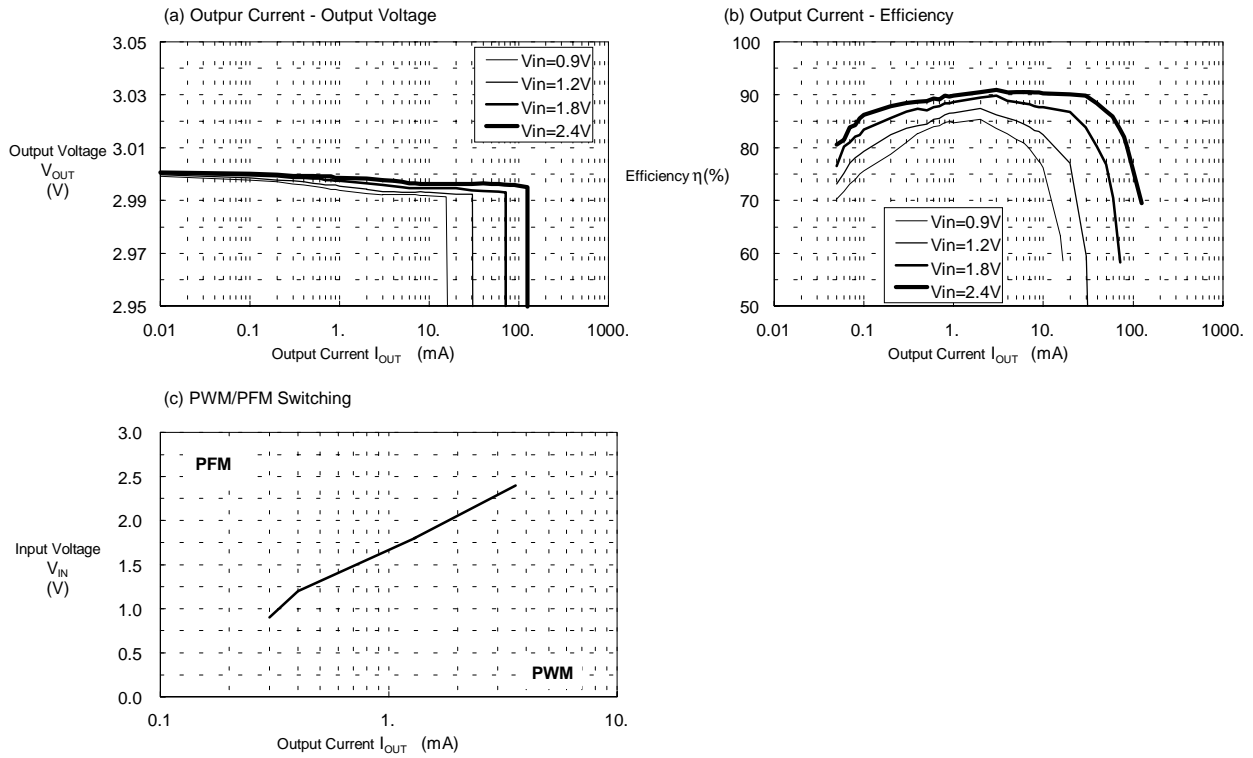




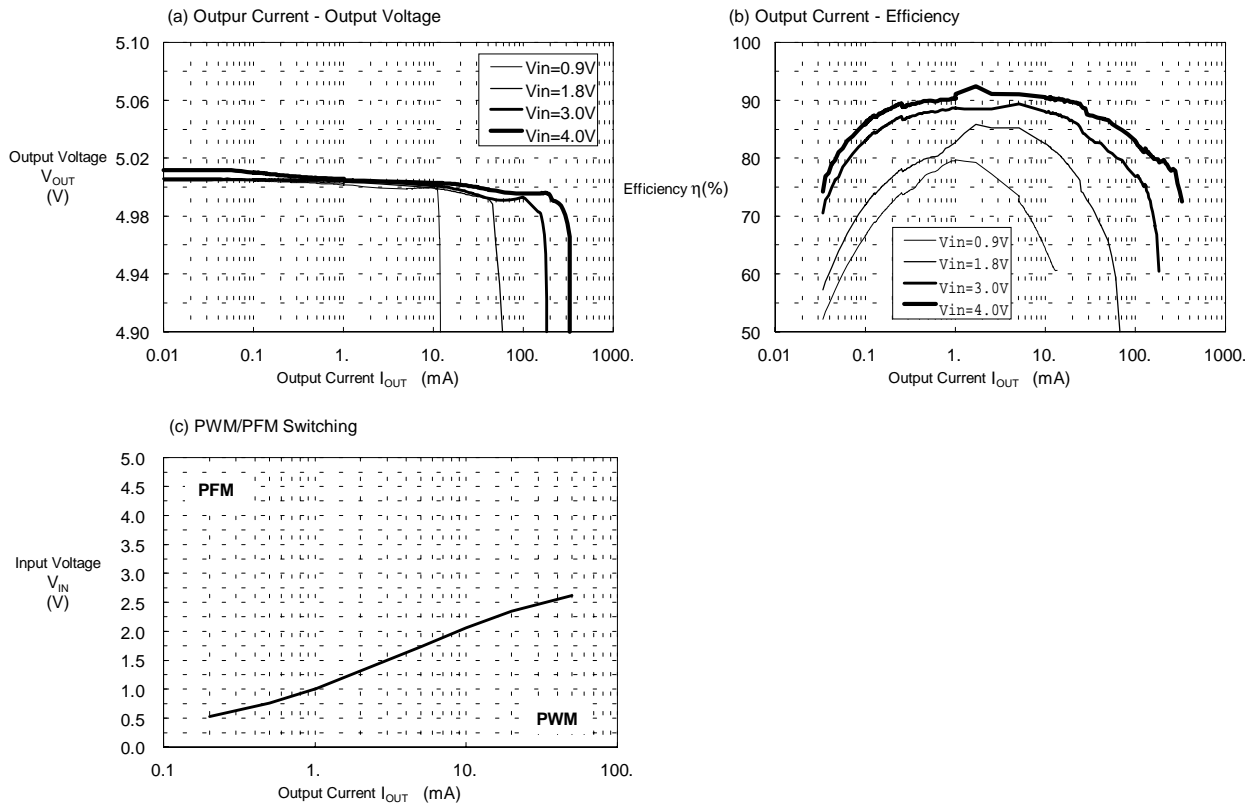
# SMALL PACKAGE PWM/PFM CONTROL STEP-UP SWITCHING REGULATOR

## S-8324/8328 Series

### (6) S-8324A30 (CD54 : 220 $\mu$ H)



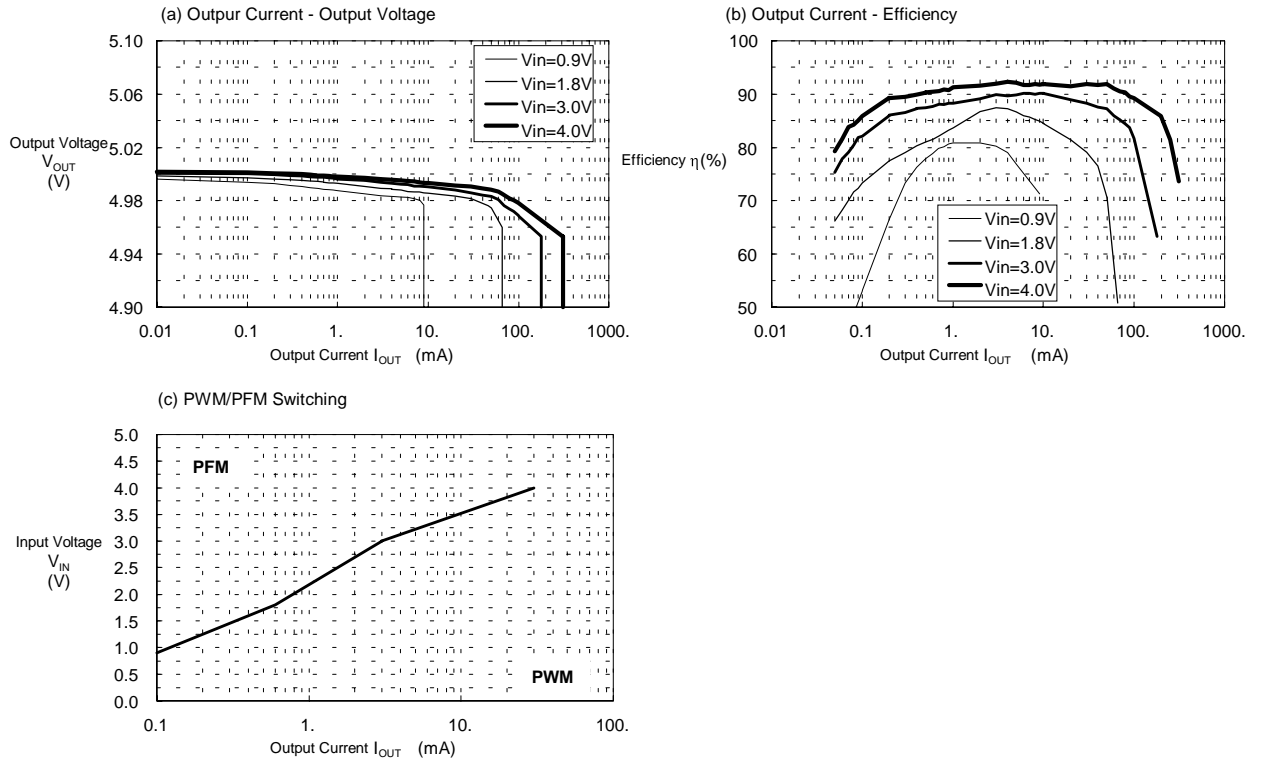
### (7) S-8324A50 (CD54 : 47 $\mu$ H)



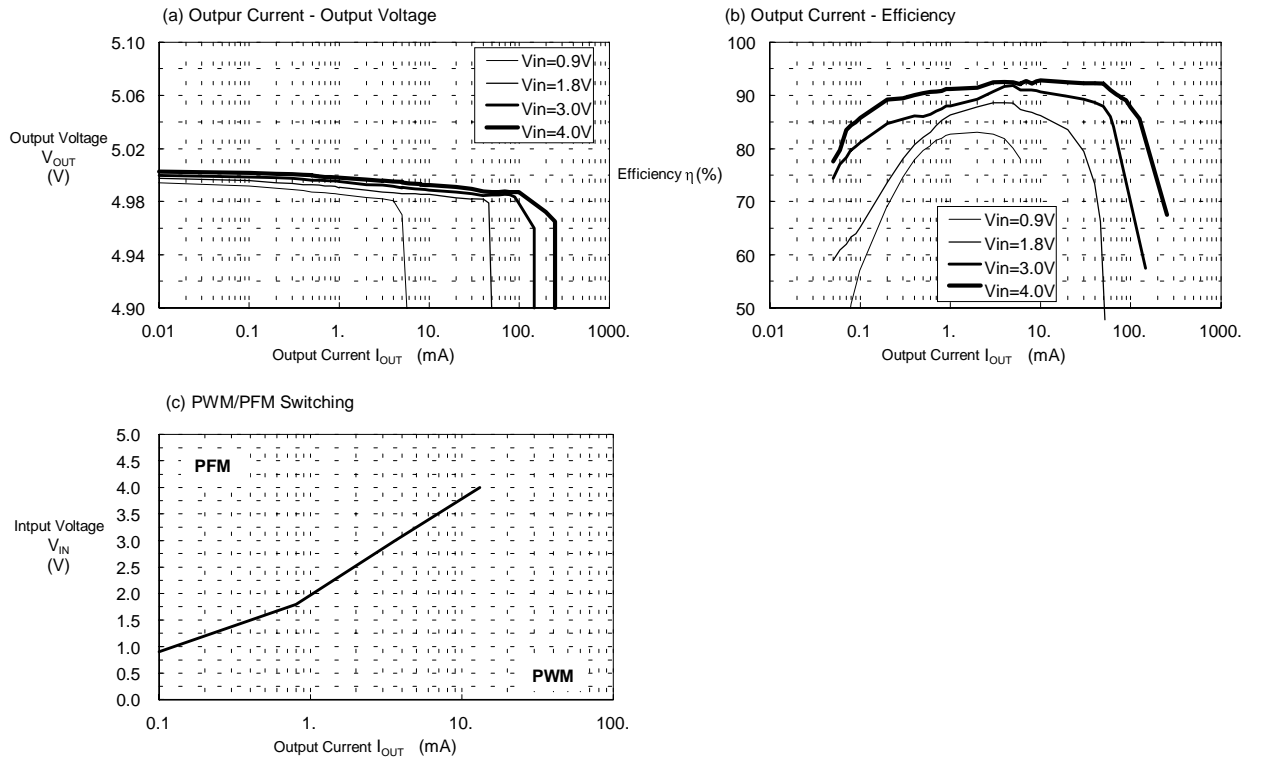
# SMALL PACKAGE PWM/PFM CONTROL STEP-UP SWITCHING REGULATOR

## S-8324/8328 Series

### (8) S-8324A50 (CD54 : 100 $\mu$ H)



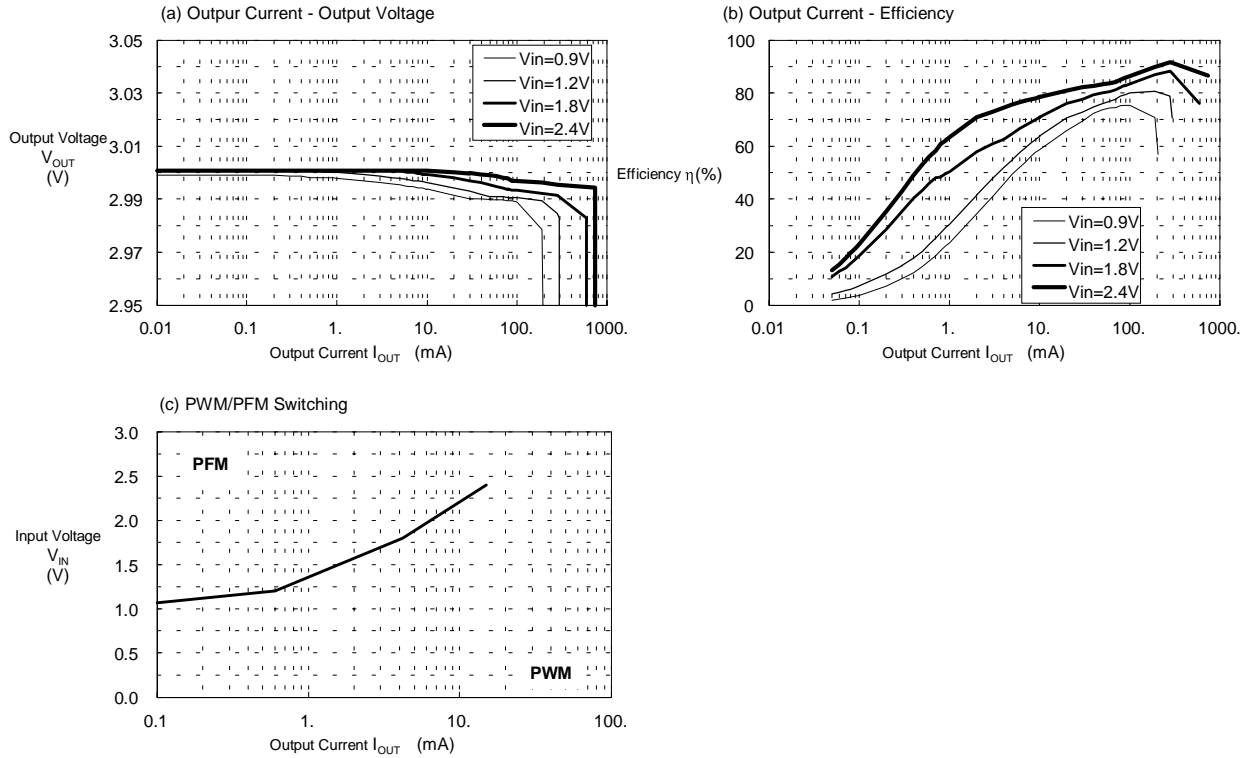
### (9) S-8324A50 (CD54 : 220 $\mu$ H)



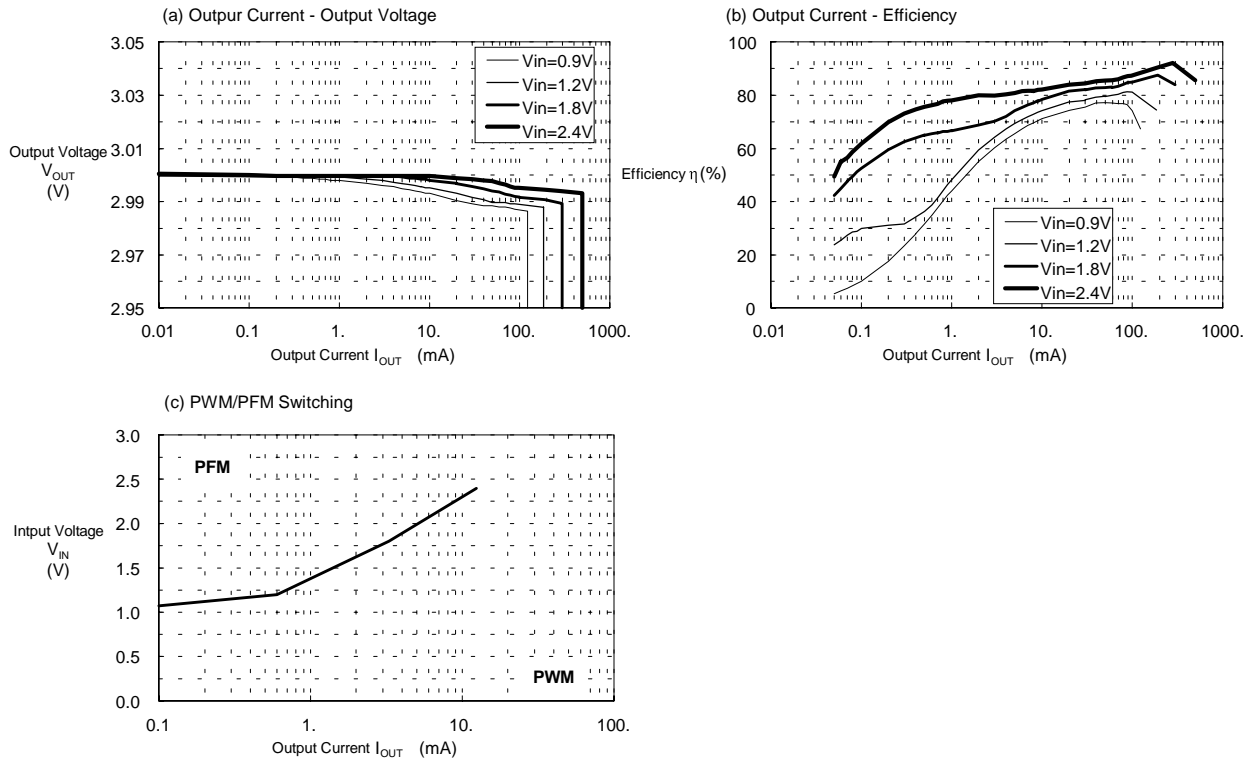
# SMALL PACKAGE PWM/PFM CONTROL STEP-UP SWITCHING REGULATOR

## S-8324/8328 Series

### (10) S-8328B30 (CD105 : 22 $\mu$ H, R<sub>b</sub>=300 $\Omega$ , C<sub>b</sub>=0.01 $\mu$ F)



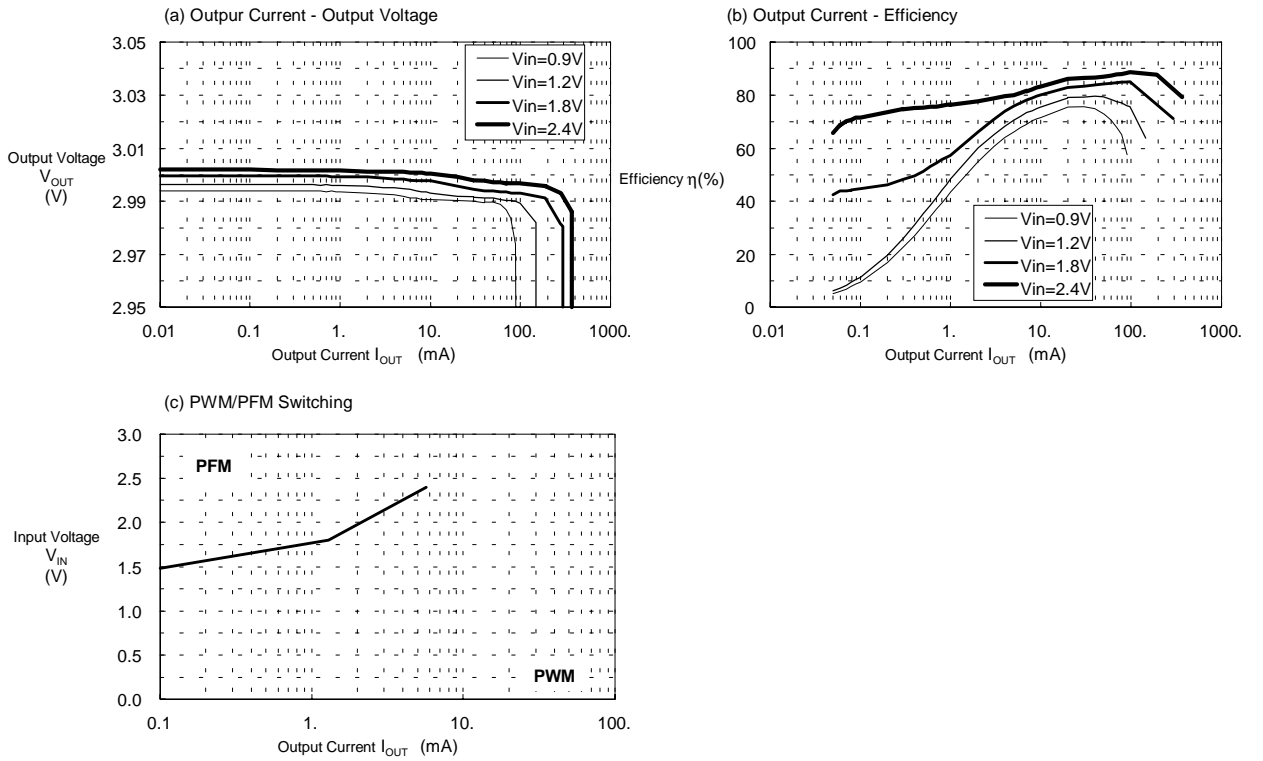
### (11) S-8328B30 (CD105 : 22 $\mu$ H, R<sub>b</sub>=1k $\Omega$ , C<sub>b</sub>=0.0022 $\mu$ F)



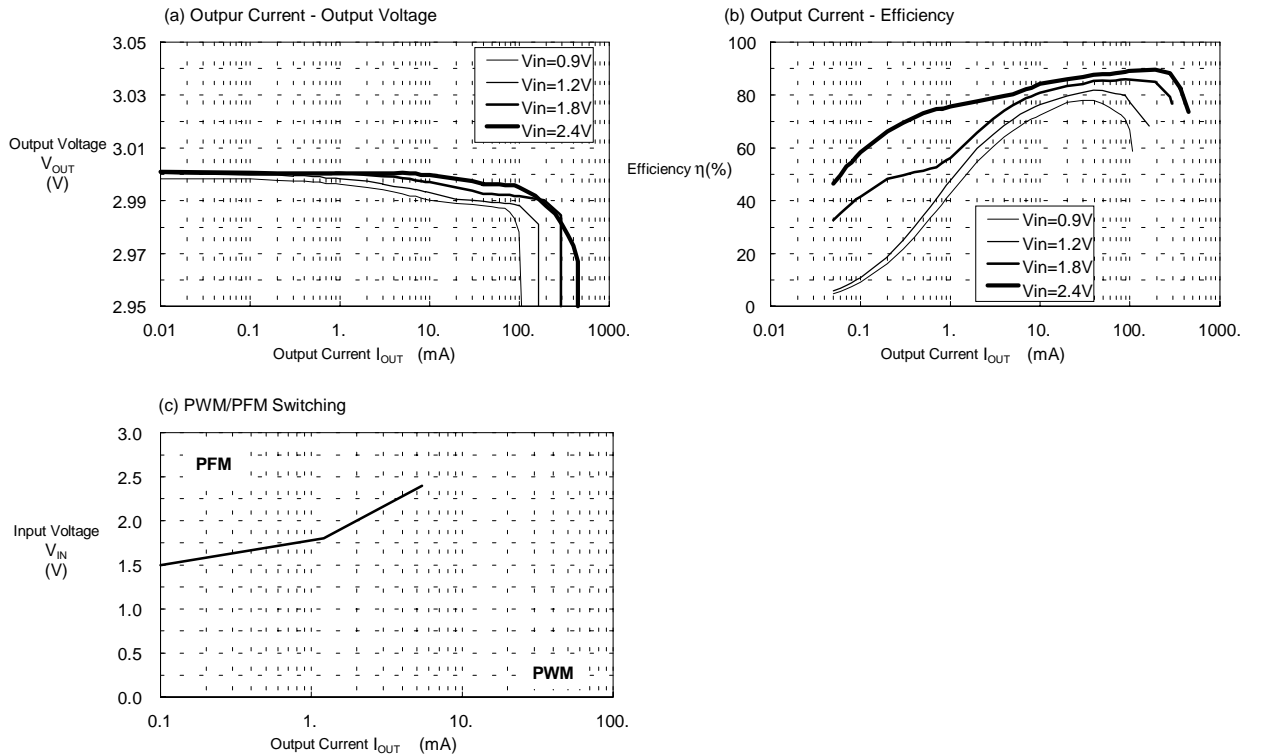
# SMALL PACKAGE PWM/PFM CONTROL STEP-UP SWITCHING REGULATOR

## S-8324/8328 Series

**(12) S-8328B30 (CD54 : 47 $\mu$ H, Rb=1k $\Omega$ , Cb=0.0022 $\mu$ F)**



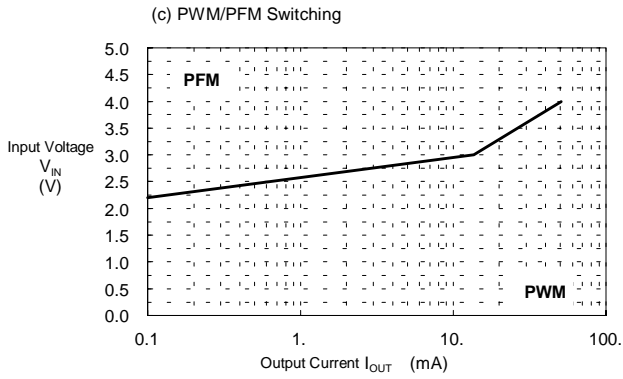
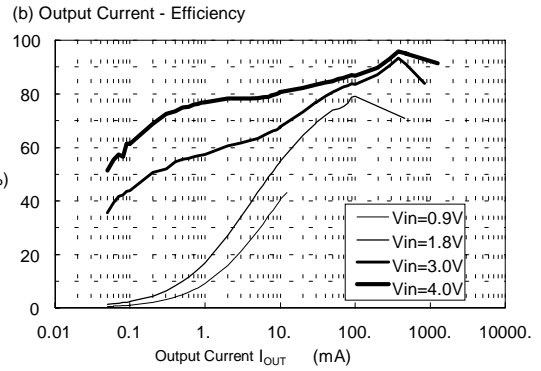
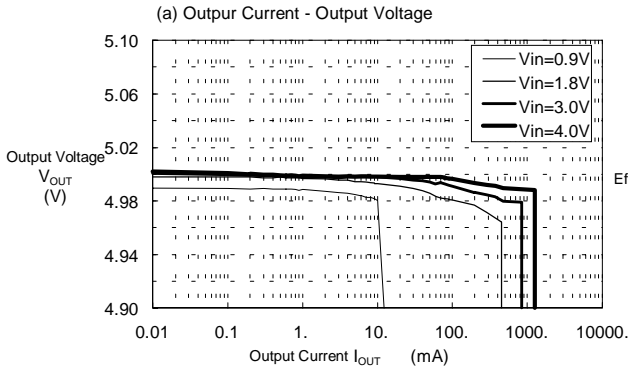
**(13) S-8328B30 (D75C : 47 $\mu$ H, Rb=1k $\Omega$ , Cb=0.0022 $\mu$ F)**



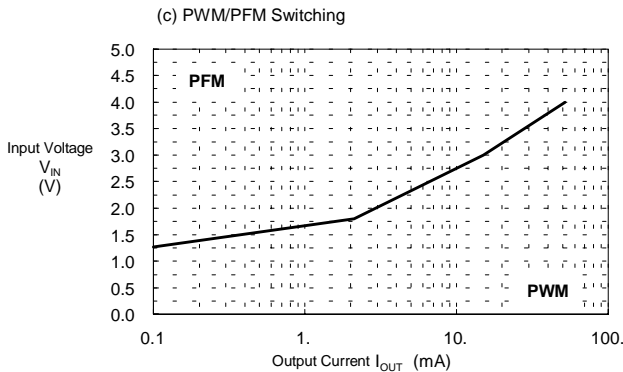
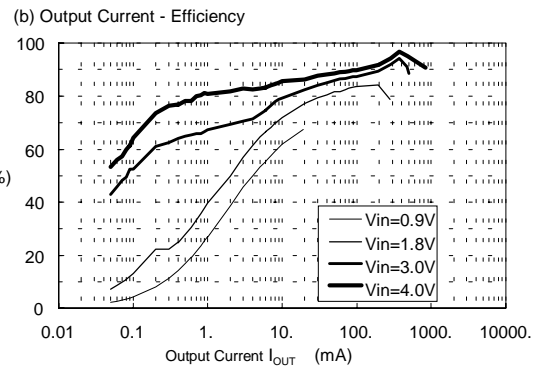
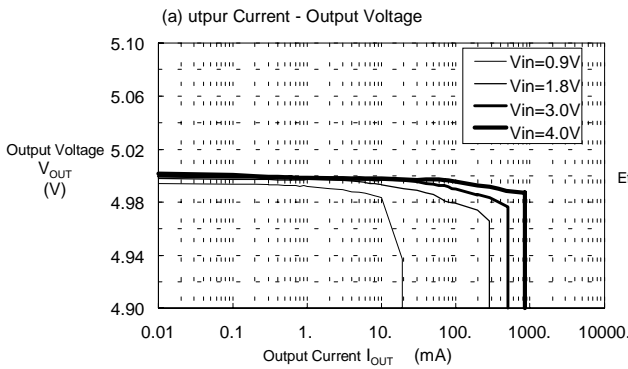
# SMALL PACKAGE PWM/PFM CONTROL STEP-UP SWITCHING REGULATOR

## S-8324/8328 Series

(14) S-8328B50 (CD105 : 22 $\mu$ H, Rb=300 $\Omega$ , Cb=0.01 $\mu$ F)



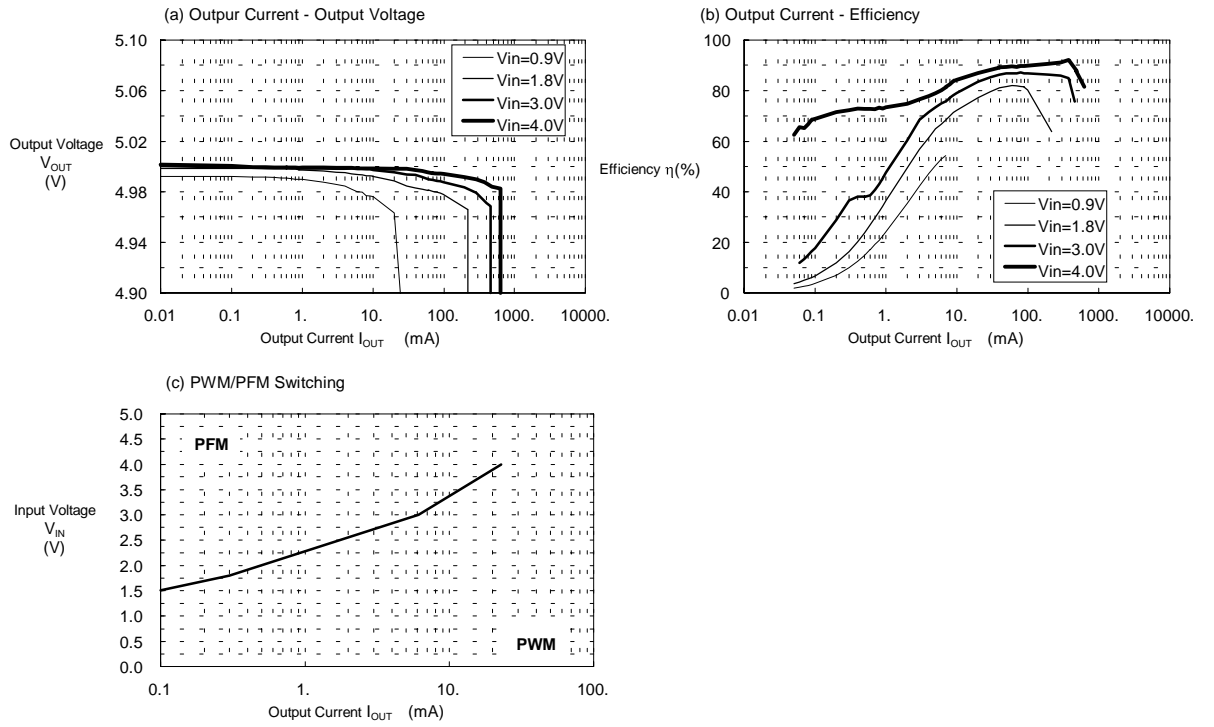
(12) S-8328B50 (CD105 : 22 $\mu$ H, Rb=1k $\Omega$ , Cb=0.0022 $\mu$ F)



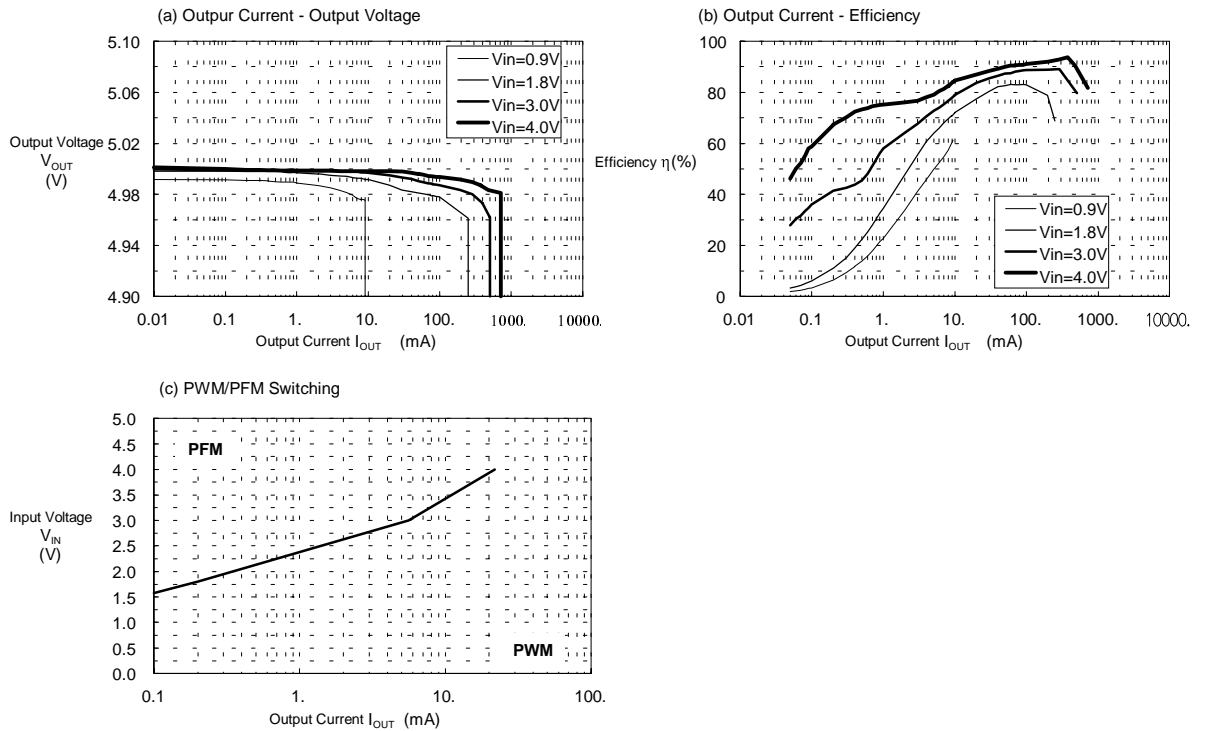
# SMALL PACKAGE PWM/PFM CONTROL STEP-UP SWITCHING REGULATOR

## S-8324/8328 Series

**(16) S-8328B50 (CD54 : 47 $\mu$ H, Rb=1k $\Omega$ , Cb=0.0022 $\mu$ F)**



**(17) S-8328B50 (D75C : 47 $\mu$ H, Rb=1k $\Omega$ , Cb=0.0022 $\mu$ F)**



# SMALL PACKAGE PWM/PFM CONTROL STEP-UP SWITCHING REGULATOR

## S-8324/8328 Series

### Reference data 2

Ripple voltage characteristics data are shown below.

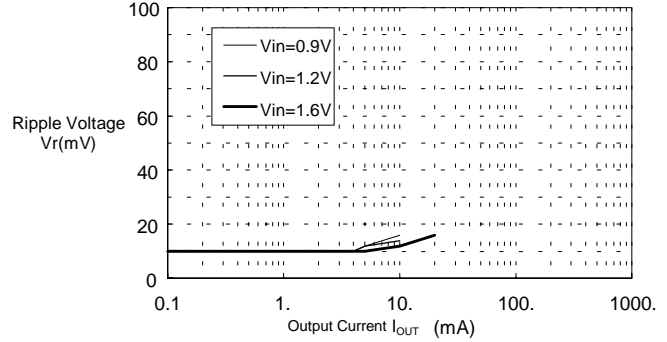
**(1) S-8324A20**

(LQH3C : 220 $\mu$ H, C<sub>OUT</sub>=22 $\mu$ F)

Similar to (2)

**(2) S-8324A20**

(LQH4N : 220 $\mu$ H, C<sub>OUT</sub>=22 $\mu$ F)



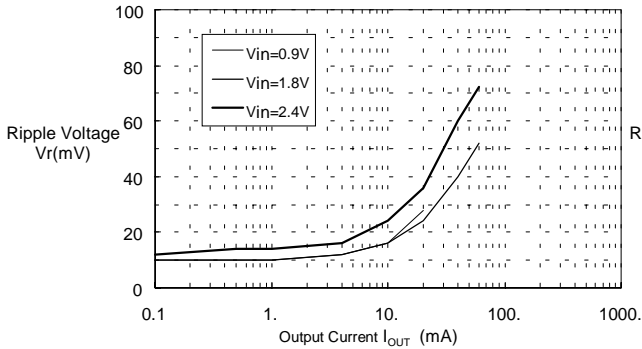
**(3) S-8324A30**

(LQH4N : 220 $\mu$ H, C<sub>OUT</sub>=22 $\mu$ F)

similar to (6)

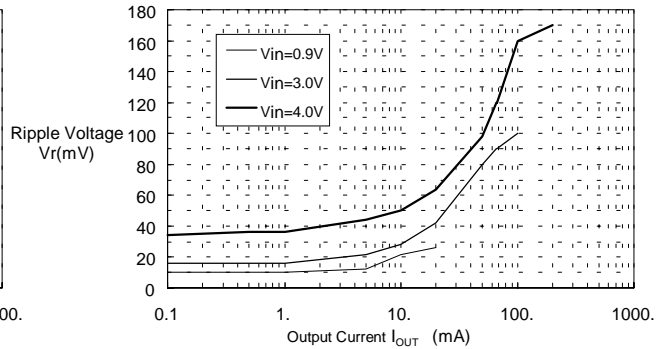
**(4) S-8324A30**

(CD54 : 47 $\mu$ H, C<sub>OUT</sub>=22 $\mu$ F)



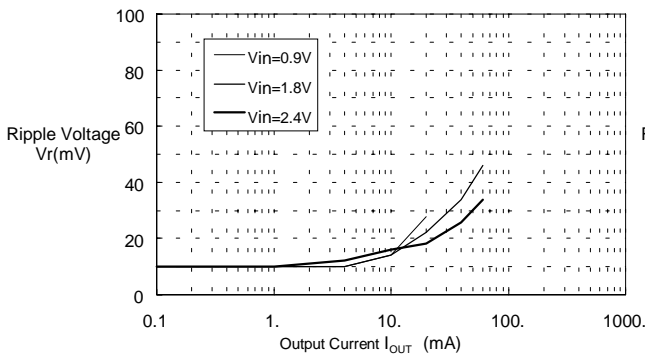
**(5) S-8324A50**

(CD54 : 47 $\mu$ H, C<sub>OUT</sub>=22 $\mu$ F)



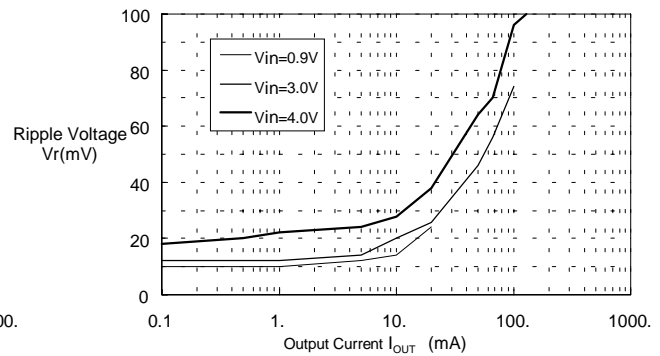
**(6) S-8324A30**

(CD54 : 100 $\mu$ H, C<sub>OUT</sub>=22 $\mu$ F)



**(7) S-8324A50**

(CD54 : 100 $\mu$ H, C<sub>OUT</sub>=22 $\mu$ F)

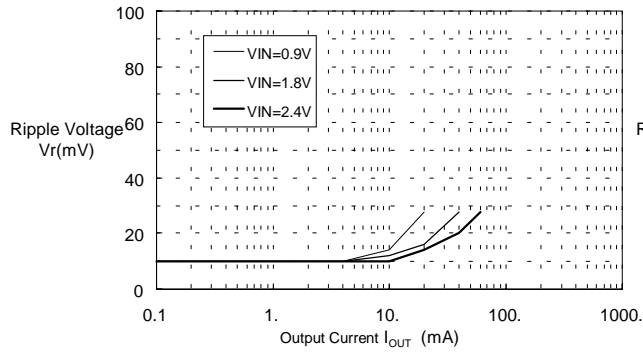


# SMALL PACKAGE PWM/PFM CONTROL STEP-UP SWITCHING REGULATOR

## S-8324/8328 Series

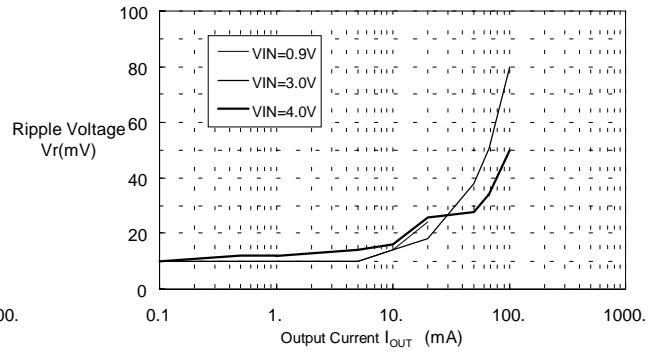
**(8) S-8324A30**

(CD54 : 220 $\mu$ H, C<sub>OUT</sub>=22 $\mu$ F)



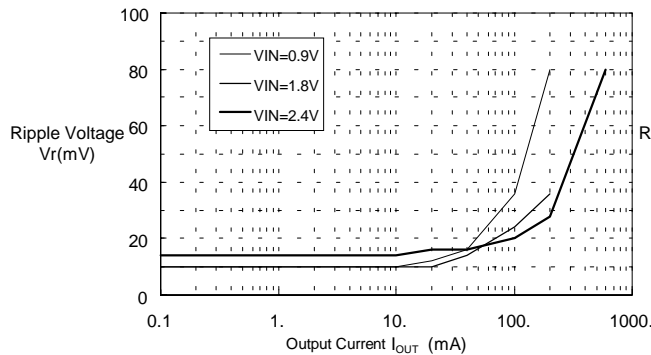
**(9) S-8324A50**

(CD54 : 220 $\mu$ H, C<sub>OUT</sub>=22 $\mu$ F)



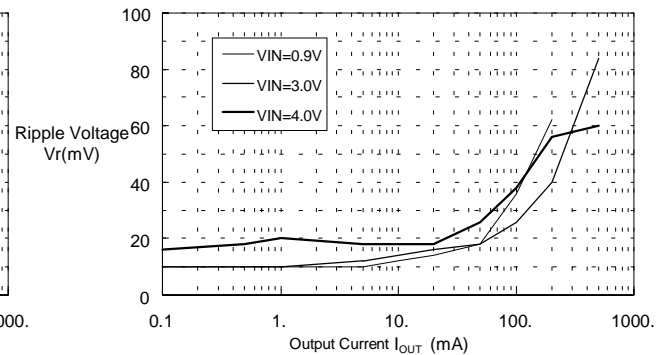
**(10) (11) S-8328B30**

(CD105 : 22 $\mu$ H, C<sub>OUT</sub>=47 $\mu$ F $\times$ 2)



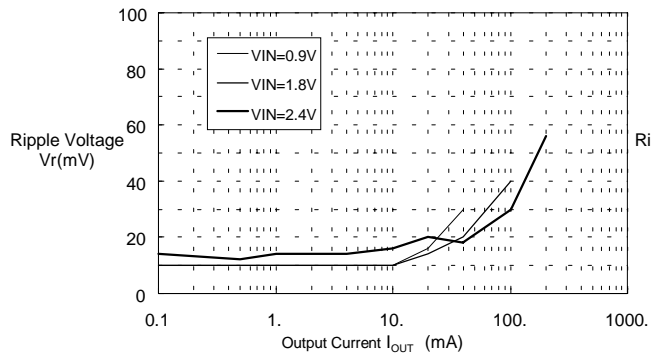
**(14) (15) S-8328B50**

(CD105 : 22 $\mu$ H, C<sub>OUT</sub>=47 $\mu$ F $\times$ 2)



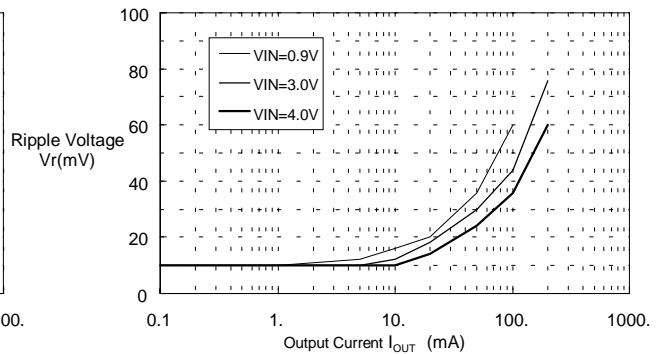
**(12) S-8328B30**

(CD54 : 47 $\mu$ H, C<sub>OUT</sub>=47 $\mu$ F)



**(16) S-8328B50**

(CD54 : 47 $\mu$ H, C<sub>OUT</sub>=47 $\mu$ F)



**(13) S-8328B30**

(D75C : 47 $\mu$ H, C<sub>OUT</sub>=47 $\mu$ F)

Similar to (12)

**(17) S-8328B50**

(D75C : 47 $\mu$ H, C<sub>OUT</sub>=47 $\mu$ F)

Similar to (16)



# Collection of Product FAQs

Author: Tachibana Midori

Date: 98/11/12 (Thursday) 10:17 (Modified:)

## <Information level>

B: For Distri & Rep (Printing N.G.)

Index: B: Technical

## <Product>

Division name: 01 IC

Category 1: 11 Power Supply

Category 2: 4. Switching Regulators

Cal No.: S-8323/24/27/28

Related Documents:

## Question:

What about the soft-start mechanism of the S-8323/24/27/28?

## Answer:

The soft-start function has been added to prevent overshoot of the output voltage when the boosting operation is initiated, and to suppress the rush current during voltage increases. The following are among the soft-start methods available:

- ① Placing a current limit on the switching current
- ② Slowly increasing the reference voltage
- ③ Limiting on-duty at the start

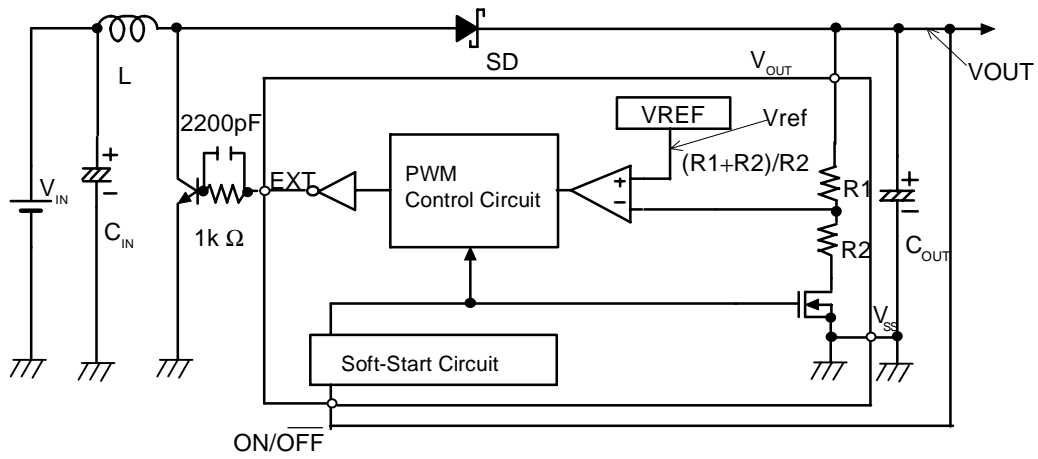
This IC adopts method ② above.

The waveforms observed when the S-8327B30 is soft-started are shown below. As reference voltage VREF within the measurement circuit is increased slowly from 0 V, output voltage VOUT also slowly increases. [Vref indicated with dotted lines in the waveform is the value obtained when reference voltage VREF is converted to an output voltage VOUT level ( $V_{ref} = V_{REF} \times (R1 + R2) \div R2$ ).]

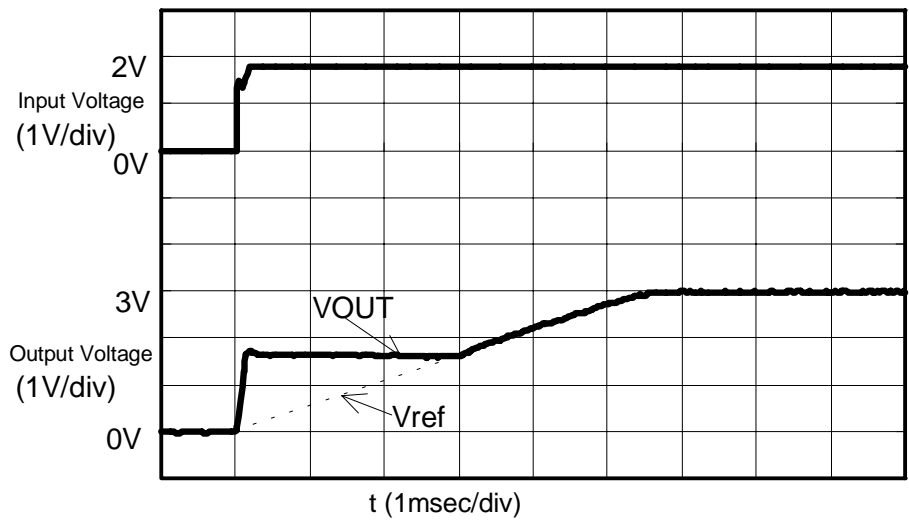
VOUT increases to close to VIN immediately after the power is switched on, as the current is supplied from VIN to VOUT via L and SD of the measurement circuit. Moreover, the soft-start function implemented by an output-power regulation circuit allows an extended soft-start time to be ensured when a large external Cc is selected.

(Refer to FAQ No. 11S8323007.)

Measurement Circuit: S-8327B30 VIN = 0 → 1.8 V IOUT = 1 mA



Waveforms



<Remarks>

FAQ No.: 11S8323013

# Collection of Product FAQs

Author: Tachibana Midori

Date: 98/11/12 (Thursday) 10:17 (Modified:)

<Information level>

A: Public (Printing O.K.)

Index: B: Technical

<Product>

Division name: 01 IC

Category 1: 11 Power Supply

Category 2: 4. Switching Regulators

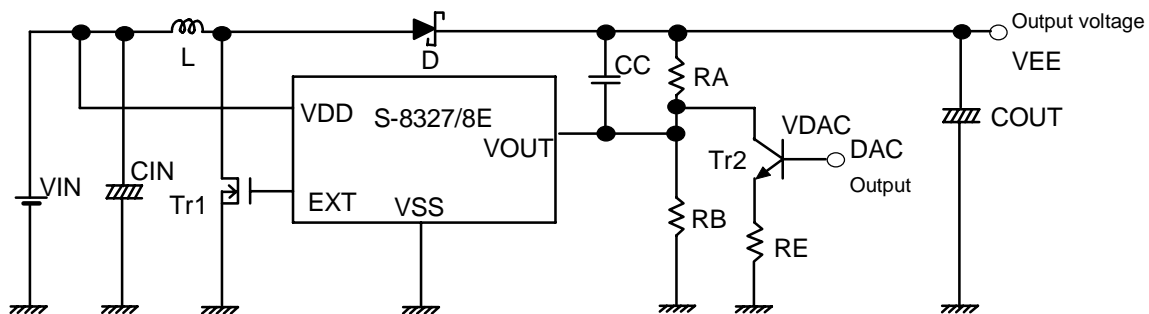
Cal No.: S-8323/24/27/28

Related Documents:

## Question:

Is there any way to adjust the output-voltage value using the DAC output of a microcomputer, etc.?

## Answer:



The output voltage can be adjusted by adding Tr2 and RE to the output-voltage regulation circuit in the above circuit diagram. If the internal resistance of VOUT, etc. is not taken into account, output voltage VEE can be represented by the following equation:

$$VEE = VOUT \times \frac{RA + RB}{RB} + RA \times \frac{VDAC - VBE}{RE}$$

The above equation indicates that output voltage VEE changes with variations in DAC output voltage VDAC of a microcomputer, etc.

The minimum value (VEEmin.) and maximum value (VEEmax.) of the output-voltage adjustment range are defined as follows:

1. Disregard Tr2 and RE, and set RA, RB, and CC such that the output voltage will be less than VEEmin. The procedure for this should comply with FAQ No. 11S8323007. (In particular, use of the software is recommended.)
2. Then, set an RE that will allow the output voltage to exceed VEEmax. when Tr2 comes on. Such a value can be found using the following equation, where OUTmin. is the minimum deviation value (OUTmin. resulting from software calculation) of the voltage VEE computed in 1. above, VDACmax. is the maximum value of the DAC output, and VBE is the base-emitter voltage of Tr2. (However, deviations in the resistance values of RA and RB must be taken into consideration.)

$$RE \geq \frac{(VDACmax - VBE)}{(VEEmax - OUTmin)} \times RA$$

Tr2 is a transistor designed for small signals. Select one that features a withstand voltage that is higher than the output voltage VEE to be set. Moreover, select an output voltage VOUT of the S-8327/8E that will allow the following condition to be met and will not allow saturated operation of Tr2.

$$VOUT \geq VDACmax + VBE$$

<Remarks>

FAQ No.: 11S8323012

# Collection of Product FAQs

Author: Tachibana Midori

Date: 98/11/ 12 (Thursday) 10:17 (Modified:)

<Information level>

B: For Distri & Rep (Printing N.G.)

Index:B Technical

<Product>

Division name: 01 IC

Category 1: 11 Power Supply

Category 2: 4. Switching Regulators

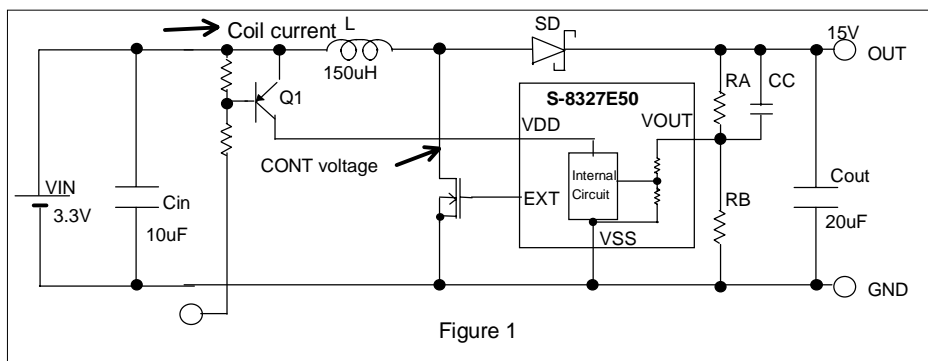
Cal No.: S-8323/24/27/28

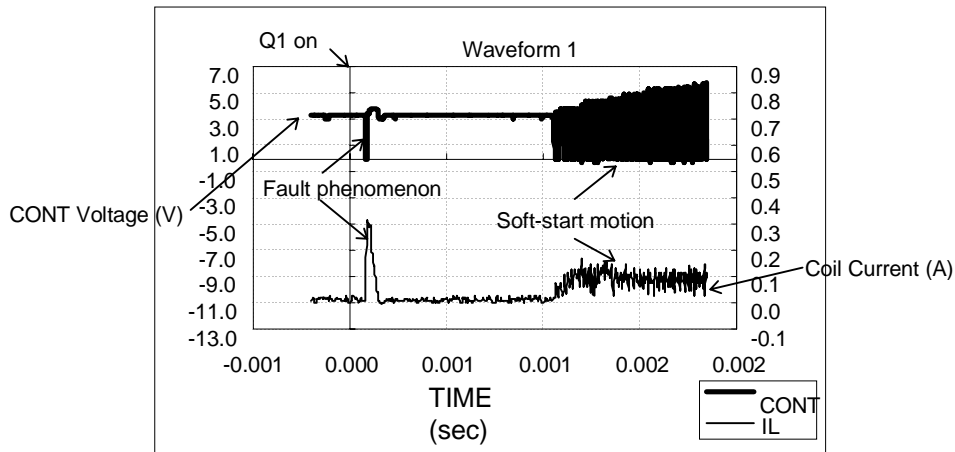
Related Documents:

## Question:

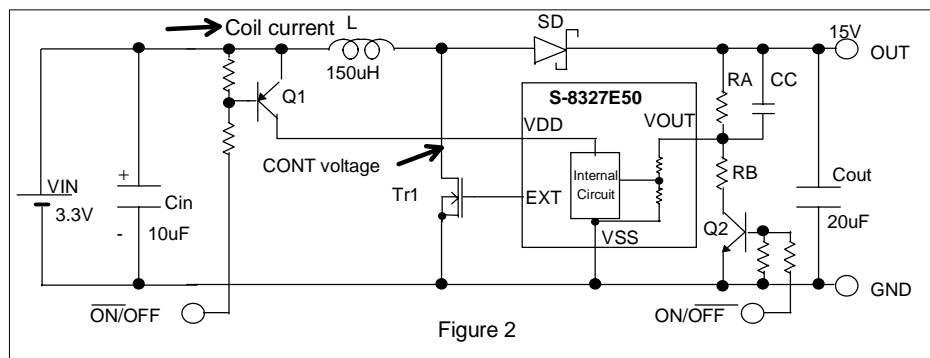
What remedial action will be taken against the phenomenon observed in an output-voltage regulation circuit, in which a boosting pulse is delivered momentarily and a rush current flows immediately after the power is switched on?

## Answer:





In the output-voltage boosting circuit shown in Figure 1, when the Vdd switch (Q1) comes on to initiate voltage boosting, full-duty switching is observed prior to the soft-start motion, as can be seen in Waveform 1, and a failure occurs, causing a large rush current to flow from VIN and the VIN voltage to drop. This occurs if the VOUT terminal voltage falls ( $V_{IN} \times R_B \div (R_A + R_B)$ ) due to the addition of RA and RB when the Vdd switch (Q1) comes on. As a result, an extended period is required to set the output voltage of the internal error amplifier circuit. One means of preventing this malfunction of the internal error amplifier circuit is turning off Q2 at the moment the Vdd switch (Q1) goes off, so that VOUT will be made equal to the VDD level via RA, as shown in Figure 2. (Normally, RA and RB are cut off in order to eliminate the reactive current generated when the power is switched off.)



<Remarks>

FAQ No.: 11S8323011

# Collection of Product FAQs

Author: Tachibana Midori

Date: 98/11/12 (Thursday) 10:17 (Modified:)

## <Information level>

B: For Distri & Rep (Printing N.G.)

Index: B: Technical

## <Product>

Division name: 01 IC

Category 1: 11 Power Supply

Category 2: 4. Switching Regulators

Cal No.: S-8323/24/27/28

## Related Documents:

## Question:

How can the duty ratio in the boosting motion of a 100-kHz product be calculated?

## Answer:

Basically, the duty ratio at the time of the boosting motion varies depending on such conditions as the input voltage  $V_{IN}$ , output voltage  $V_{OUT}$ , load current  $I_{OUT}$ , coil value  $L$ , oscillation frequency  $f_{osc}$ , and Schottky diode voltage  $V_F$ . If these conditions are known, the duty ratio can be roughly computed using the following equation:

$$\text{Duty} = L \times f_{osc} \div V_{IN} \times \sqrt{(2 \times I_{OUT} \times (V_{OUT} - V_F - V_{IN}) \div f_{osc} \div L)}$$

(The above equation can be derived from Formulas (4) and (17) in the Data Book and  $\text{Duty} = t_{on} \times f_{osc}$ .)

However, it is essential that the duty value given by the above equation be smaller than the duty value computed below (non-continuous mode).

$$\text{Duty} \leq \text{duty} = (V_{OUT} - V_F - V_{IN}) \div (V_{IN} + (V_{OUT} - V_F - V_{IN}))$$

## <Remarks>

FAQ No.: 11S8323010

# Collection of Product FAQs

Author: Tachibana Midori

Date: 98/11/12 (Thursday) 10:17 (Modified:)

<Information level>

A: Public (Printing O.K.)

Index: B: Technical

<Product>

Division name: 01 IC

Category 1: 11 Power Supply

Category 2: 4. Switching Regulators

Cal No.: S-8323/24/27/28

Related Documents:

## Question:

What is the basic concept of the S-8323 peak current?

## Answer:

1.  $I_{pk}$  in boosting

The basic concept is as follows:

① Loss  $P_{on}$  of  $V_{IN}$  due to  $i_L$  in the figure below is:

$$P_{on} = \frac{1}{2} \times L \times f_{osc} \times I_{pk}^2$$

② Loss  $P_{off}$  of  $V_{IN}$  due to  $i_2$  in the figure below is:

$$P_{off} = \frac{1}{2} \times L \times f_{osc} \times I_{pk}^2 \times \frac{V_{IN}}{V_{out} - V_{IN}}$$

③ Assuming that ①+② is equal to energy  $P_{out}$  supplied from  $V_{out}$ ,

$$I_{out} \times V_{out} = P_{on} + P_{off}$$

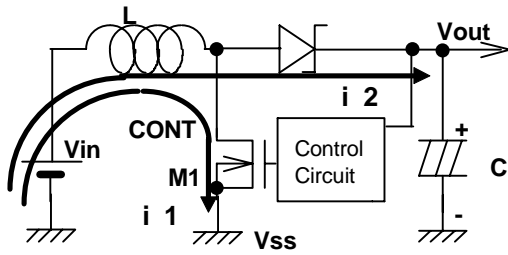
$$I_{out} = \frac{1}{2} \times L \times f_{osc} \times I_{pk}^2 \times \frac{1}{V_{out} - V_{IN}}$$

$$I_{pk} = \sqrt{\frac{2 \times I_{out} \times (V_{out} - V_{IN})}{L \times f_{osc}}}$$



Sample  
boosting circuit:

$V_{in} < V_{out}$



2.  $I_{pk}$  in inversion

The basic concept is as follows:

- ① Loss  $P_{on}$  of  $V_{IN}$  due to  $i_1$  in the figure below is:

$$P_{on} = \frac{1}{2} \times L \times f_{osc} \times I_{pk}^2$$

- ② Loss  $P_{off}$  of  $V_{IN}$  due to  $i_2$  in the figure below is:

$$P_{off} = 0$$

- ③ Assuming that ①+② is equal to energy  $P_{out}$  supplied from  $V_{out}$ ,

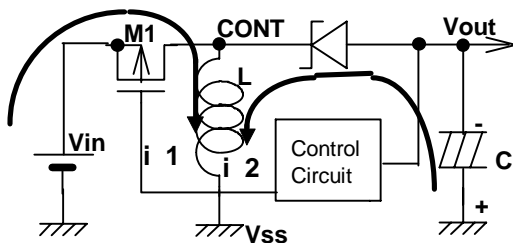
$$I_{out} \times V_{out} = P_{on}$$

$$I_{out} = \frac{1}{2} \times \frac{1}{V_{out}} \times L \times f_{osc} \times I_{pk}^2$$

$$I_{pk} = \sqrt{\frac{2 \times I_{out} \times V_{out}}{L \times f_{osc}}}$$

Sample  
inversion circuit:

$0 < V_{in} < V_{out}$



<Remarks>

FAQ No.: 11S8323009

# Collection of Product FAQs

Author: Tachibana Midori

Date: 98/11/12 (Thursday) 10:17 (Modified:)

## <Information level>

X: Working

Index: B: Technical

## <Product>

Division name: 01 IC

Category 1: 11 Power Supply

Category 2: 4. Switching Regulators

Cal No.: S-8323/24/27/28

Related Documents:

## Question:

What about using MOS FET siliconix/TN200T externally connected to the S-8328B?

## Answer:

Power dissipation when Siliconix/TN200T is used.

Results:

- Version 3.3 V did not have the required capacity of  $I_{out} = 400 \text{ mA}$  (at  $V_{IN}=1.8 \text{ V}$ ) when Siliconix/TN0200T was employed.
- Version 5 V did not exceed the power dissipation of Siliconix/TN0200T at  $I_{out} = 200 \text{ mA}$  (at  $V_{IN}=1.8 \text{ V}$ ).

Description of study:

Loss P under the worst possible conditions ( $V_{IN}=1.8 \text{ V}$ ,  $I_{out}=200 \text{ mA}$ ) was calculated.

$$\begin{aligned} P &= (I_{contave} \times \text{duty})^2 \times R_{on} \\ &= (0.84\text{A} \times 76\%)^2 \times 0.4\Omega \\ &= 0.163\text{w} \leq \text{PD} (0.23\text{w}) \end{aligned}$$

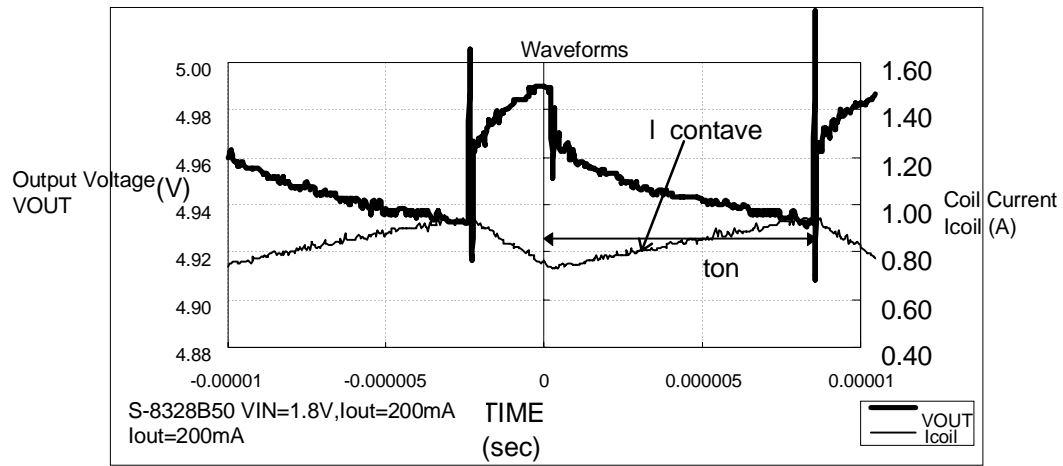
Where,

$I_{contave}$ : Average current that flows through the external MOS FET, TRS at the time of  $t_{on}$ . This is a measured value (see the waveforms below).

duty: Ratio of  $t_{on}$  to the switching period. This is a measured value (see the waveforms below).

$R_{on}$ : Drain-source resistance value when Siliconix/TN0200T comes on. This is the maximum value of the specification.

PD: Package power dissipation of Siliconix/TN0200T. This is the maximum value of the specification.



<Remarks>

FAQ No.: 11S8323008

# Collection of Product FAQs

Author: Tachibana Midori

Date: 98/11/12 (Thursday) 10:17 (Modified: )

## <Information level>

A: Public (Printing O.K.)

Index: B: Technical

## <Product>

Division name: 01 IC

Category 1: 11 Power Supply

Category 2: 4. Switching Regulators

Cal No.: S-8323/24/27/28

Related documents:

## Question:

What is the maximum temperature coefficient of the output voltage?

## Answer:

The worst temperature coefficient of the output voltage is as follows:

S-8323~8 410 ppm/°C

When this value is applied to  $V_{OUT}=2\text{ V}$ , the temperature coefficient of the output voltage,  $\Delta V_{out}/\Delta T_a$  (mV/°C), as defined by the SII specifications, is given as:

S-8323~8  $\pm 0.82\text{ mV/°C}$  (410 ppm/°C x 2 V)

Note that this is an actual value and is not guaranteed as a specification.

## <Remarks>

FAQ No.: 11S8323006

# Collection of Product FAQs

Author: Tachibana Midori

Date: 98/11/12 (Thursday) 10:17 (Modified: )

## <Information level>

A: Public (Printing O.K.)

Index: B: Technical

## <Product>

Division name: 01 IC

Category 1: 11 Power Supply

Category 2: 4 Switching Regulators

Cal No.: S-8323/24/27/28

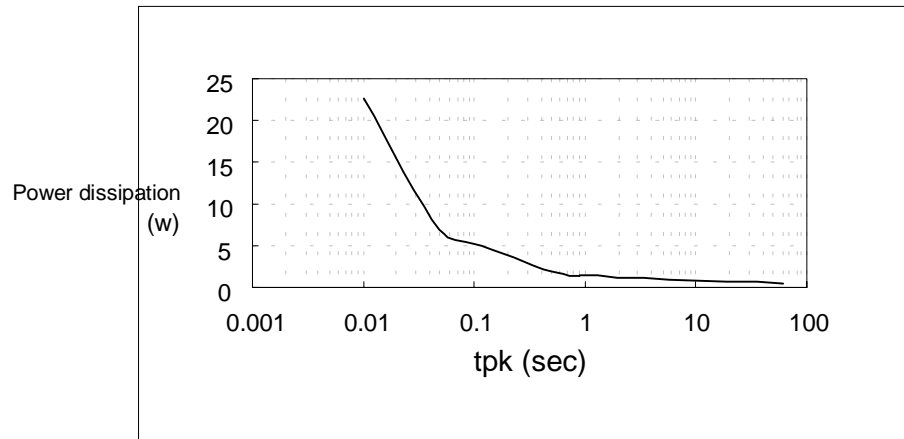
Related documents:

## Question:

At start-up of S-8323~4, a large peak current flows through the CONT terminal. Is it possible that the peak current could cause a loss that exceeds the power dissipation?

## Answer:

The power dissipation for S-8323~4 is 500 mW when the SOT-89 package is used, and 150 mW when the SOT-23 package is used. However, these power dissipation are only applicable when the loss is steady. At start-up, the large peak current at the CONT terminal lasts only until the output voltage increases to the preset value. Based on actually measured data using the SOT-23 package, the power dissipation for the peak current duration (tpk) at the CONT terminal is shown in the figure below. For example, when the peak current duration (tpk) at the CONT terminal is 100 m SEC, the power dissipation is up to 5 W; the peak current is up to 1 A if CONT=5 V.



<Remarks>

FAQ No.: 11S8323005

# Collection of Product FAQs

Author: Tachibana Midori

Date: 98/11/12 (Thursday) 10:17 (Modified: )

<Information level>

A: Public (Printing O.K.)

Index: B: Technical

<Product>

Division name: 01 IC

Category 1: 11 Power Supply

Category 2: 4. Switching Regulators

Cal No.: S-8323/24/27/28

Related documents:

## Question:

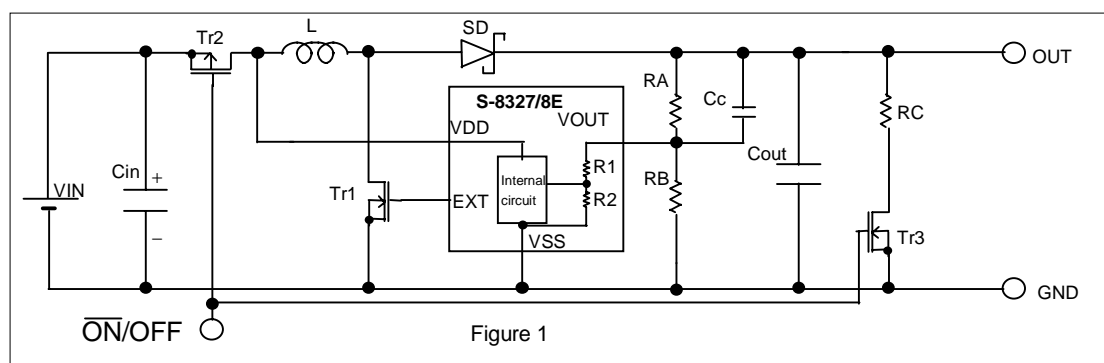
In the output-voltage regulator circuit described on the data sheet, how can the output be discharged to GND when the power is turned off?

## Answer:

- ① If the rush current flowing from the input power supply does not cause a problem when the power is turned on:

When turning off the power, switch off SWR from VIN.

Since Tr 2 is off when the power is off, turn on Tr 3 to discharge Cout through RC.



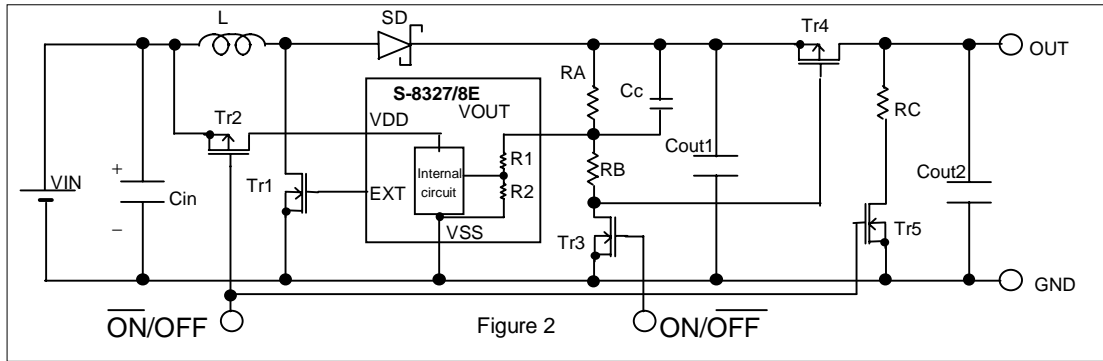
- ② If the rush current causes a problem when the power is turned on:

When turning off the power, switch off the VDD of IC and the GND side of the external resistance.

Since Tr 3 and Tr 4 are off when the power is off, turn on Tr 5 to discharge Cout 2 through RC.

Two sets of inputs for turning on the power, a positive logic and a negative logic, are required.

Compared with Figure 1, additional external parts are also required (two Tr's and a capacitor).



<Remarks>

FAQ No.: 11S8323004



# Collection of Product FAQs

Author: Tachibana Midori

Date: 98/11/12 (Thursday) 10:17 (Modified: )

<Information level>

A: Public (Printing O.K.)

Index: B: Technical

<Product>

Division name: 01 IC

Category 1: 11 Power Supply

Category 2: 4. Switching Regulators

Cal No.: S-8323/24/27/28

Related documents:

## Question:

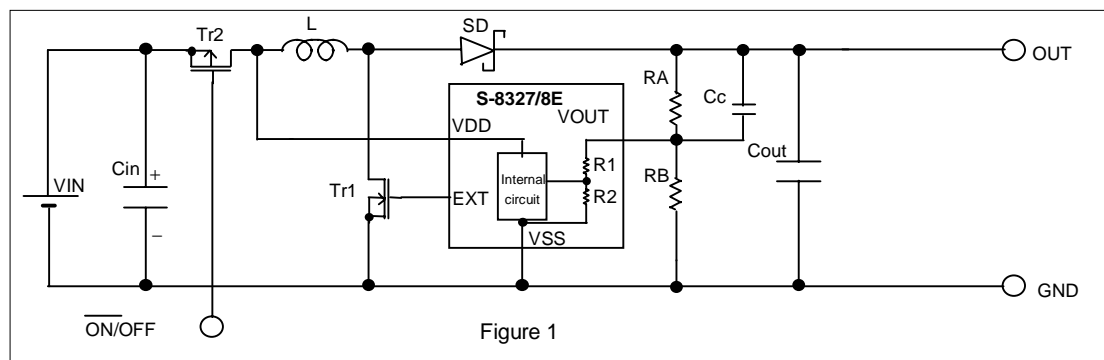
In the output-voltage regulator circuit described on the data sheet, how is the power turned off?

## Answer:

- ① If the rush current does not cause a problem when the power is turned on:

When turning off the power, switch off SWR from VIN.

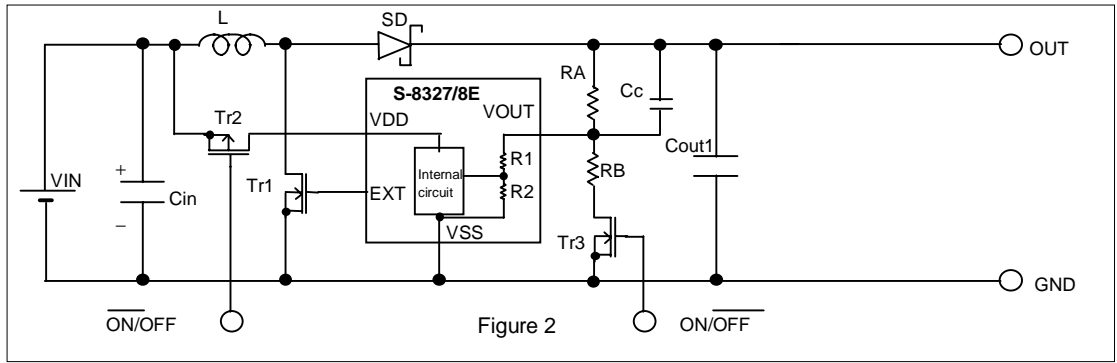
When the power is turned on (VIN and SWR are connected), a rush current flows at Cout.



- ② If the rush current causes a problem when the power is turned on:

When turning off the power, switch off VDD of IC and the GND side of the external resistance.

Two sets of inputs for turning on the power, a positive logic and a negative logic, are required. To restrict the rush current, increase the capacitance of Cc so that the soft start-up time is prolonged.



<Remarks>

FAQ No.: 11S8323003

# Collection of Product FAQs

Author: Tachibana Midori

Date: 98/11/12 (Thursday) 10:17 (Modified: )

## <Information level>

A: Public (Printing O.K.)

Index: B: Technical

## <Product>

Division name: 01 IC

Category 1: 11 Power Supply

Category 2: 4. Switching Regulators

Cal No.: S-8323/24/27/28

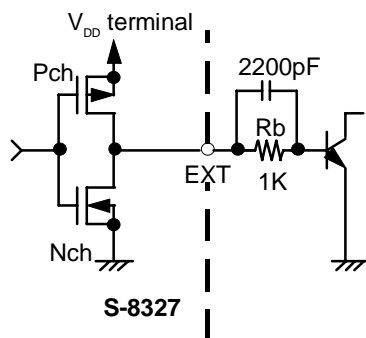
Related documents:

## Question:

In the separated VDD type of S-8327/8, what is the output amplitude at the EXT terminal?

## Answer:

The amplitude of the EXT output is from GND to the power-supply voltage of the internal circuit of the S-8327/8 series. For normal types (A, B, C, and F series), the EXT output amplitude is from GND to VOUT due to the fact that the power for the internal circuit is supplied from the VOUT terminal. For the separated VDD type (D, E, and G series), the EXT output amplitude is from GND to VDD due to the fact that the power-supply voltage for the internal circuit occurs at the VDD terminal. For example, the EXT output amplitude will be from GND to VIN when the potential of VIN is applied to the VDD terminal.



Peripheral circuit including an external transistor

## <Remarks>

FAQ No.: 11S8323002

# Collection of Product FAQs

Author: Tachibana Midori

Date: 98/11/12 (Thursday) 10:17 (Modified: )

## <Information level>

A: Public (Printing O.K.)  
Index: B: Technical

## <Product>

Division name: 01 IC  
Category 1: 11 Power Supply  
Category 2: 4. Switching Regulators  
Cal No.: S-8323/24/27/28

Related documents:

## Question:

How can we ensure high efficiency?

## Answer:

Follow these instructions:

- Make sure the allowable current (maximum rating) of the used coil is greater than the peak current of the coil. (If the current exceeds the allowable value, efficiency decreases due to magnetic saturation.)
- Select an external diode with low VF characteristics and a short first-recovery time.
- The equivalent series resistance (ESR) of the output capacitor, Cout, significantly affects efficiency. Select a low ESR.
- In the external-switching transistor type (S-8322 S-8327/8), the ON resistance varies with the base resistance Rb (the resistance between the EXT terminal and the external transistor base), thereby affecting efficiency. (Efficiency decreases as Rb increases.) It should also be noted that the current consumption increases as the Rb value decreases, resulting in a decrease in efficiency.

## <Remarks>

FAQ No.: 11S8323001