

IC for System Reset Monolithic IC PST993, 994

April 25, 2002

Outline

This IC functions in a variety of CPU systems and other logic systems, to detect supply voltage and reset the system accurately when the power is turned on or interrupted. Considering replacement from discrete reset circuits, it is designed to be simplified, which achieves low-cost implementation.

Features

- | | | | | | | | | | | | |
|---|--|-----------------|----------|----------|----------|----------|----------|----------|----------|----------|----------|
| 1. Voltage detect precision | $V_S \pm 5\%$ max. | | | | | | | | | | |
| 2. Low current consumption | $I_{CCH} = 300\mu A$ typ. $I_{CCL} = 250\mu A$ typ. | | | | | | | | | | |
| 3. Low operating limit voltage | 0.65V typ. | | | | | | | | | | |
| 4. Hysteresis voltage provided for detect voltage | 50mV typ. | | | | | | | | | | |
| 5. Large output current during power-on | 15mA typ. | | | | | | | | | | |
| 6. Detection voltage rank | <table border="0"> <tr> <td>PST993 C : 4.5V</td> <td>H : 3.1V</td> </tr> <tr> <td>D : 4.2V</td> <td>I : 2.9V</td> </tr> <tr> <td>E : 3.9V</td> <td>J : 2.7V</td> </tr> <tr> <td>F : 3.6V</td> <td>K : 2.5V</td> </tr> <tr> <td>G : 3.3V</td> <td>L : 2.3V</td> </tr> </table> <p>(Same ranks for PST994)</p> | PST993 C : 4.5V | H : 3.1V | D : 4.2V | I : 2.9V | E : 3.9V | J : 2.7V | F : 3.6V | K : 2.5V | G : 3.3V | L : 2.3V |
| PST993 C : 4.5V | H : 3.1V | | | | | | | | | | |
| D : 4.2V | I : 2.9V | | | | | | | | | | |
| E : 3.9V | J : 2.7V | | | | | | | | | | |
| F : 3.6V | K : 2.5V | | | | | | | | | | |
| G : 3.3V | L : 2.3V | | | | | | | | | | |
| 7. Output configuration | | | | | | | | | | | |
| PST993 : Internal constant-current load | | | | | | | | | | | |
| PST994 : Open collector | | | | | | | | | | | |

Packages

TO-92A (PST993□, PST994□)

*The box represents a rank of detection voltage.

Applications

1. Reset circuits for microcomputers, CPUs and MPUs
2. Reset circuits for logic circuits
3. Level detection circuits

Pin Assignment

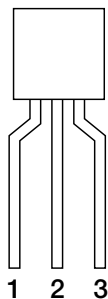

1	V_{CC}
2	GND
3	V_{OUT}

TO-92A

Equivalent Circuit Diagram

■ PST993

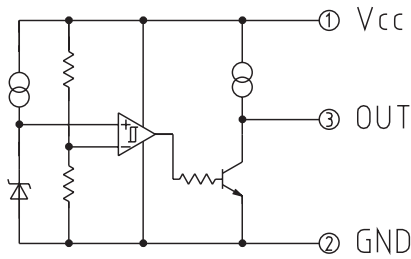

■ PST994

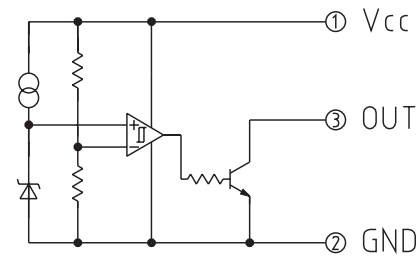

Absolute Maximum Ratings (Ta=25°C) (PST993)

Item	Symbol	Ratings	Units
Storage temperature	T _{STG}	-40~+125	°C
Operating temperature	T _{OPR}	-20~+75	°C
Supply voltage	V _{CC}	-0.3~+10	V
Allowable loss	P _d	300	mW

Electrical Characteristics (Ta=25°C) (The unit of resistance is Ω unless otherwise indicated.)

Item	Symbol	Measurement Circuit	Measurement conditions	Min.	Typ.	Max.	Units	
Detection Voltage	V _s	1	R _L =∞ V _{CC} =H→L	PST993C	4.27	4.50	4.73	V
				PST993D	4.00	4.20	4.40	
				PST993E	3.70	3.90	4.10	
				PST993F	3.42	3.60	3.78	
				PST993G	3.13	3.30	3.47	
				PST993H	2.94	3.10	3.26	
				PST993I	2.75	2.90	3.05	
				PST993J	2.56	2.70	2.84	
				PST993K	2.37	2.50	2.63	
				PST993L	2.18	2.30	2.42	
Hysteresis Voltage	ΔV _s	1	R _L =∞, V _{CC} =L→H→L	30	50	100	mV	
Detection Voltage Temperature Coefficient	V _s /ΔT	1	R _L =∞, Ta=-20~+75°C		±0.01		%/°C	
Low Level Output Voltage	V _{OL}	1	V _{CC} =V _s min. -0.05V, R _L =1k		0.1	0.4	V	
Output Constant Current	I _{oC}	1	V _O =2.5V, V _{CC} =5V, R _L =∞	-40	-25	-17	μA	
Circuit Current at ON Time	I _{cCL}	1	V _{CC} =V _s min. -0.05V, R _L =∞		250	400	μA	
Circuit Current at OFF Time	I _{cCH}	1	V _{CC} =V _s typ. /0.85V, R _L =∞		300	500	μA	
"H" Transmission Delay Time	tpLH	2	C _L =100pF		20 *1		μs	
"L" Transmission Delay Time	tpHL	2	C _L =100pF		1		μs	
Operating Threshold Voltage	V _{oPL}	1	R _L =4.7k, V _{OL} ≤ 0.4V		0.65	0.85	V	
Output Current at ON Time 1	I _{oL1}	1	R _L =∞, V _O =0.4V V _{CC} =V _s min. -0.05V	6	15		mA	
Output Current at ON Time 2	I _{oL2}	1	Ta=-20~+75°C, R _L =∞ V _O =0.4V, V _{CC} =V _s min. -0.05V	4			mA	

*Do not apply onto the OUT terminal any voltage higher than that at the V_{CC} terminal.

(*1) The tpLH is a function of the charging time of C_L by output constant current.

The delay time of this IC is about 1 μs.

Absolute Maximum Ratings (Ta=25°C) (PST994)

Item	Symbol	Ratings	Units
Storage temperature	T _{STG}	-40~+125	°C
Operating temperature	T _{OPR}	-20~+75	°C
Supply voltage	V _{CC}	-0.3~+10	V
Allowable loss	P _d	300	mW

Electrical Characteristics (Ta=25°C) (The unit of resistance is Ω unless otherwise indicated.)

Item	Symbol	Measurement Circuit	Measurement conditions	Min.	Typ.	Max.	Units	
Detection Voltage	V _s	1	R _L =1k V _{CC} =H→L	PST994C	4.27	4.5	4.73	V
				PST994D	4.00	4.2	4.40	
				PST994E	3.70	3.9	4.10	
				PST994F	3.42	3.6	3.78	
				PST994G	3.13	3.3	3.47	
				PST994H	2.94	3.1	3.26	
				PST994I	2.75	2.9	3.05	
				PST994J	2.56	2.7	2.84	
				PST994K	2.37	2.5	2.63	
				PST994L	2.18	2.3	2.42	
Hysteresis Voltage	ΔV _s	1	R _L =1k, V _{CC} =L→H→L	30	50	100	mV	
Detection Voltage Temperature Coefficient	V _s /ΔT	1	R _L =1k, Ta=-20~+75°C		±0.01		%/°C	
Low Level Output Voltage	V _{OL}	1	V _{CC} =V _s min. -0.05V, R _L =1k		0.1	0.4	V	
Output Leakage Current	I _{OH}	1	V _{CC} =10V			0.1	μA	
Circuit Current at ON Time	I _{CCL}	1	V _{CC} =V _s min. -0.05V, R _L =∞		250	400	μA	
Circuit Current at OFF Time	I _{CCH}	1	V _{CC} =V _s typ./0.85V, R _L =∞		300	500	μA	
"H" Transmission Delay Time	tp _{LH}	2	C _L =100pF, R _L =4.7k		1		μs	
"L" Transmission Delay Time	tp _{HL}	2	C _L =100pF, R _L =4.7k		1		μs	
Operating Threshold Voltage	V _{OPL}	1	R _L =4.7k, V _{OL} ≤ 0.4V		0.65	0.85	V	
Output Current at ON Time 1	I _{OL1}	1	V _O =0.4V R=∞ V _{CC} =V _s min. -0.05V	6	15		mA	
Output Current at ON Time 2	I _{OL2}	1	Ta=-20~+75°C R=∞ V _O =0.4V, V _{CC} =V _s min.-0.05V	4			mA	

*Do not apply onto the OUT terminal any voltage higher than that at the V_{CC} terminal.

(*1) The tp_{LH} is a function of the charging time of C_L by output constant current.

The delay time of this IC is about 1 μs.

Equivalent Circuit Diagram

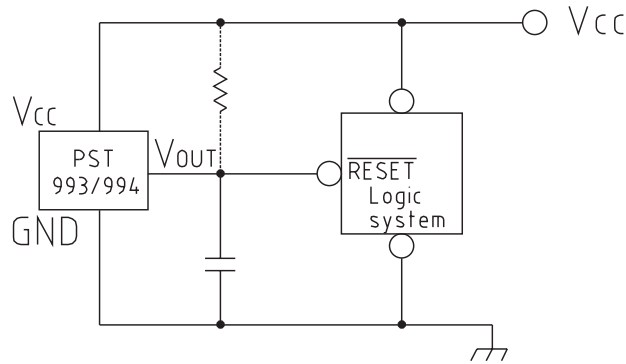

* Since PST993 incorporates a constant current load, the pull-up resistance is not necessary.

Characteristics

■ Vs vs. Ta

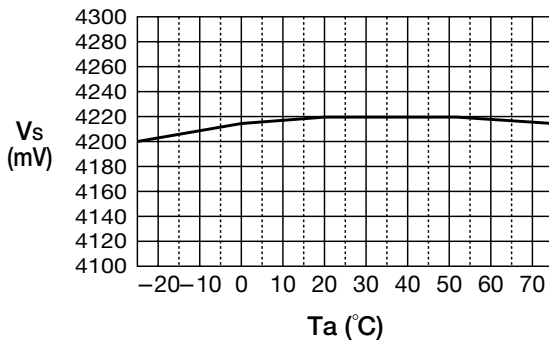

■ VopL vs. Ta

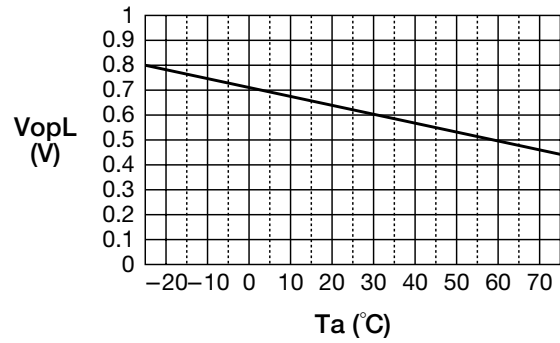

■ ΔVs vs. Ta

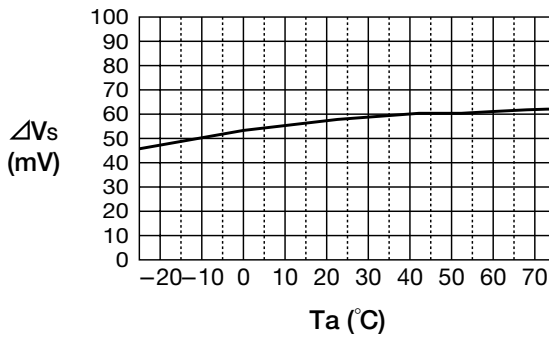

■ VoL vs. Ta

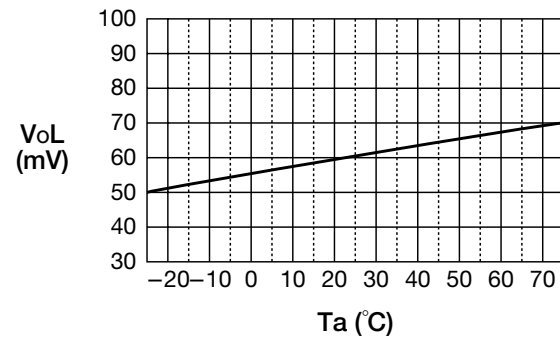

■ IccH vs. Ta

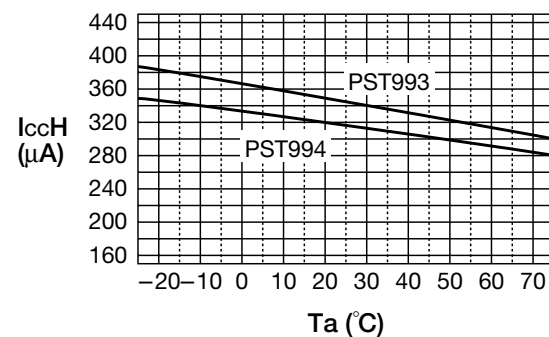

■ IoC vs. Ta (PST993)

